

—
ABB
Electrification Business
Business Line Smart Buildings
www.abb.com/lowvoltage

FONLEE
豐立自動控制器材有限公司
WWW.FONLEE.COM.TW

Note:
We reserve the right to make technical changes or modify the contents of this document without prior notice.
With regard to purchase orders, the agreed particulars shall prevail. ABB does not accept any responsibility whatsoever for potential errors or possible lack of information in this document. We reserve all rights in this document and in the subject matter and illustrations contained therein. Any reproduction, disclosure to third parties or utilization of its contents – in whole or in parts – is forbidden without prior written consent of ABB.
Copyright© 2019 ABB All rights reserved

TECHNICAL CATALOGUE 2019

S800

The High Performance MCB



FONLEE
豐立自動控制器材有限公司
www.fonlee.com.tw

Table of contents

S800

ORDERING DETAILS

PROPERTIES OF
MAIN DEVICES S800

TECHNICAL DATA

POLE DIMENSIONS

APPROVALS AND
CERTIFICATIONS

FONLEE
豐立自動控制器材有限公司
WWW.FONLEE.COM.TW

1

2

3

4

5

Overview S800

		S800S B, C, D, K	S803S-KM KM	S800S-UC UCB, UCK	S800N B, C, D	S800C B, C, D, K
Tripping characteristics						
Standards		IEC/EN 60947-2, IEC/EN 60898-1, UL 1077	IEC/EN 60947-2	IEC/EN 60947-2	IEC/EN 60947-2, IEC/EN 60898-1	IEC/EN 60947-2, EN 60898-1, UL 1077
Poles		1 ... 4	3	1 ... 4	1 ... 4	1 ... 4
Rated current I_n	A	0.5 ... 125	10 ... 80	0.5 ... 125	6 ... 125	10 ... 125
Rated frequency f	Hz	50/60	50/60	50/60	50/60	50/60
Rated insulation voltage U_i acc. to IEC/EN 60664-1	V	AC 690	AC 690	DC 1000	AC 690	AC 500
Rated impulse withstand voltage U_{imp} (1.2/50µs)	kV	8	8	8	8	8
Overvoltage category	IV	IV	IV	IV	IV	IV
Pollution degree		3	3	1- and 2-pole: 3 3- and 4-pole: 2	3	3
Suitability for isolation		yes	yes	yes	yes	yes
Data acc. to IEC/EN 60898-1						
Rated operational voltage U_e	V	AC 230/400	-	-	AC 230/400	AC 230/400
Rated short-circuit capacity I_{cn}	kA	Char. B, C, D: 230/400 V (10 ... 80A) = 25 kA	-	-	230/400V (10 ... 80A) = 20 kA	Char. B, C, D: 230/400V = 15 kA
Service short-circuit capacity I_{cs}	kA	Char. B, C, D: 230/400 V (10 ... 80A) = 12.5 kA	-	-	230/400V (10 ... 80A) = 10 kA	Char. B, C, D: 230/400V = 7.5 kA
Data acc. to IEC/EN 60947-2						
Rated operational voltage U_e	V	AC 400/690 1-pole: DC 125 2-pole: DC 250 3-pole: DC 375 4-pole: DC 500	AC 690	1-pole: DC 250 2-pole: DC 500 3-pole: DC 750 4-pole (63 ... 125A): DC 750 4-pole (10 ... 50A): DC 1000	AC 400/690 1-pole: DC 125 2-pole: DC 250 3-pole: DC 375 4-pole: DC 500	AC 254/440 1-pole: DC 125 2-pole: DC 250 3-pole: DC 375 4-pole: DC 500
Rated ultimate short-circuit capacity I_{cu}	kA	AC 240/415 V = 50 kA AC 254/440 V = 30 kA AC 289/500 V (up to 80 A) = 15 kA AC 289/500 V (100 ... 125 A) = 10 kA AC 400/690 V (up to 80 A) = 6 kA AC 400/690 V (100 ... 125 A) = 4.5 kA DC 125 V (1-pole) = 30 kA DC 250 V (2-pole) = 30 kA DC 375 V (3-pole) = 30 kA DC 500 V (4-pole) = 30 kA	AC 240/415V = 50 kA AC 254/440V = 30 kA AC 400/690V = 6 kA DC 375V = 30 kA	DC 250V (1-pole) = 50 kA DC 500V (2-pole) = 50 kA DC 750V (3-pole) = 50 kA DC 750V (4-pole) (63...125A) = 50 kA DC 1000 (4-pole) (10...50A) = 50 kA	AC 240/415 V = 36 kA AC 254/440 V = 20 kA AC 289/500 V = 10 kA AC 400/690 V = 4.5 kA DC 125 V (1-pole) = 20 kA DC 250 V (2-pole) = 20 kA DC 375 V (3-pole) = 20 kA DC 500 V (4-pole) = 20 kA	AC 240/415V = 25 kA AC 254/440V = 15 kA DC 125V (1-pole) = 10 kA DC 250V (2-pole) = 10 kA DC 375V (3-pole) = 10 kA DC 500V (4-pole) = 10 kA
Rated service short-circuit capacity I_{cs}	kA	AC 240/415 V = 40 kA AC 254/440 V (up to 80 A) = 22.5 kA AC 254/440 V (100 ... 125 A) = 15 kA AC 289/500 V (up to 80 A) = 11 kA AC 289/500 V (100 ... 125 A) = 5 kA AC 400/690 V (up to 80 A) = 4 kA AC 400/690 V (100 ... 125 A) = 3 kA DC 125 V (1-pole) = 30 kA DC 250 V (2-pole) = 30 kA DC 375 V (3-pole) = 30 kA DC 500 V (4-pole) = 30 kA	AC 240/415V = 40 kA AC 254/440V = 22.5 kA AC 400/690V = 4 kA DC 375V = 30 kA	DC 250V (1-pole) = 50 kA DC 500V (2-pole) = 50 kA DC 750V (3-pole) = 50 kA DC 750V (4-pole) (63...125A) = 50 kA DC 1000 (4-pole) (10...50A) = 50 kA	AC 240/415 V = 30 kA AC 254/440 V (up to 63 A) = 15 kA AC 254/440 V (80 ... 125 A) = 10 kA AC 289/500 V (up to 80 A) = 8 kA AC 289/500 V (100 ... 125) = 5 kA AC 400/690 V = 3 kA DC 125 V (1-pole) = 20 kA DC 250 V (2-pole) = 20 kA DC 375 V (3-pole) = 20 kA DC 500 V (4-pole) = 20 kA	AC 240/415V = 18 kA AC 254/440V = 10 kA DC 125V (1-pole) = 10 kA DC 250V (2-pole) = 10 kA DC 375V (3-pole) = 10 kA DC 500V (4-pole) = 10 kA

Note: The minimum operating voltage for S800 is 12VAC/VDC.

Tripping characteristics	S800S B, C, D, K	S803S-KM KM	S800S-UC UCB, UCK	S800N B, C, D	S800C B, C, D, K
Data acc. to UL 1077/ CSA22.2 No 235, Supplementary Protector					
Alternating current: int. cap.	1 240: 30 (0.5...63A) 277: 14 (0.5...63A) 347: 6 (0.5...63A)				1 240: 20(≤100A) 277: 10 (≤100A)
	2,3,4 240: 30 (0.5...63A) 480 Y/277: 14 (0.5...63A) 600 Y/347: 6 (0.5...63A)				2,3,4 240: 20 (≤100A) 480 Y/277: 10 (≤100A)
Direct current: int. cap.					DC 125 (1-pole): 10 (≤100A) DC 250 (2-pole): 10 (≤100A) DC 375 (3-pole): 10 (≤100A) DC 500 (4-pole): 10 (≤100A)

Note: The minimum operating voltage for S800 is 12VAC/VDC.

FONLEE
豐立自動控制器材有限公司
WWW.FONLEE.COM.TW

Overview S800

Tripping characteristics	S800B B, C, D, K	S800HV C, K	S800U K, Z	S804U-UCZ UCZ
Standards	IEC 60947-2 EN 60898-1	IEC/EN 60947-2, UL 1077	UL489 IEC 60947-2	UL489
Poles	1 ... 4	1 ... 3	1 ... 4	4
Rated current I_n	A 32 ... 125	Char. C: 10 ... 32 Char. K: 0.5 ... 125	10 – 100	10 – 80
Rated frequency f	Hz 50/60	50/60	50/60	–
Rated insulation voltage U_i acc. to IEC/EN 60664-1	V AC 500	AC 1000	AC 690	DC 1500
Rated impulse withstand voltage U_{imp} (1.2/50µs)	kV 6	8	8	8
Overvoltage category	III	III	IV	IV
Pollution degree	3	2	3	3
Suitability for isolation	yes	yes	yes	yes
Data acc. to IEC/EN 60898-1				
Rated operational voltage U_e	V AC 230/400	–	–	–
Rated short-circuit capacity I_{cn}	kA 230/400V = 10kA	–	–	–
Service short-circuit capacity I_{cs}	kA 230/400V = 7.5kA	–	–	–
Data acc. to IEC/EN 60947-3				
Rated operational voltage U_e	V –	–	–	–
Min. operating voltage	V –	–	–	–
Rated short-term withstand current I_{cw}	kA –	–	–	–
Rated short-circuit making capacity I_{cm}	kA –	–	–	–
Utilisation category	–	–	–	–
Data acc. to IEC/EN 60947-2				
Rated operational voltage U_e	V AC 230/400	AC 580/1000	AC 240/415	–
Rated ultimate short-circuit capacity I_{cu}	kA AC 230/400V = 16kA DC 75V (1-pole) = 10kA DC 150V (2-pole) = 10kA DC 225V (3-pole) = 10kA DC 300V (4-pole) = 10kA	AC 580/1000 (0.5...5 A) = 1.5 kA (6 ... 63 A) = 4 kA (80 ... 125 A) = 3 kA	1-pole: AC 240V 30kA multipole: AC 415V 50kA	–
Rated service short-circuit capacity I_{cs}	kA AC 230/400V = 10kA	(0.5...5 A) = 1.5 kA (6 ... 63 A) = 2.5 kA (80 ... 125 A) = 2 kA	1-pole: AC 240V 25kA multipole: AC 415V 40kA	–
Data acc. to UL489/CSA22.2 No 5				
Rated voltage	V		AC 240	DC 600
Short-circuit current rating acc. to UL 489	kA		1-pole 30kA multipole: 50kA	10kA
Short-circuit current rating acc. to UL 489B	kA			
Data according to UL 1077/ CSA22.2 No 235, Supplementary Protector				
Alternating current		2, 3 600 Y/347: 15 (3P, 10...32 A)*		

* 3P, 10 ... 32 A - only valid with XT2L 125 TMF 35-400

Overview S800PV Photovoltaic

Tripping characteristics	S800PV-SP	S800PV-SD	S802PV-M-H	S804U-PVS
	SP	-	-	PVS
Standards	IEC / EN 60947-2 and Annex P	IEC / EN 60947-3 and Annex D	IEC / EN 60947-3	UL489B (Photovoltaic)
Poles	2 ... 4	2 ... 4	2 (polarized)	4
Rated current I_e	A 5 ... 125	32, 63, 125	32, 63, 100	5
Rated frequency f	Hz -	-	-	-
Rated insulation voltage U_i acc. to IEC/EN 60664-1	V DC 1500	DC 1500	DC 1500	DC 1500
Rated impulse withstand voltage U_{imp} (1.2/50µs)	kV 8	8	8	8
Overvoltage category	III	III	III	IV
Pollution degree	2	2	2	3
Suitability for isolation	yes	yes	yes	yes
Data acc. to IEC/EN 60947-3				
Rated operational voltage U_e	V -	2-pole: DC 800 3-pole: DC 1200 4-pole: DC 1500	2-pole: DC 1000	-
Min. operating voltage	V -	-	-	-
Rated short-term withstand current I_{cw}	kA -	1.5	1.5	-
Rated short-circuit making capacity I_{cm}	kA -	0.5	0.5	-
Utilisation category	-	DC-21A	DC-21A	-
Data acc. to IEC/EN 60947-2				
Rated operational voltage U_e	V	2-pole DC 800: 5 ... 125A 3-pole DC 1200: 5 ... 125A 4-pole DC 1500: 5 ... 125A	-	-
Rated ultimate short-circuit capacity I_{cu}	kA 5	-	-	-
Rated service short-circuit capacity I_{cs}	kA 5	-	-	-
Data acc. to UL / CSA				
Rated voltage	V -	-	-	DC 1000
Short-circuit current rating acc. to UL 489	kA -	-	-	-
Short-circuit current rating acc. to UL 489B	kA -	-	-	3kA

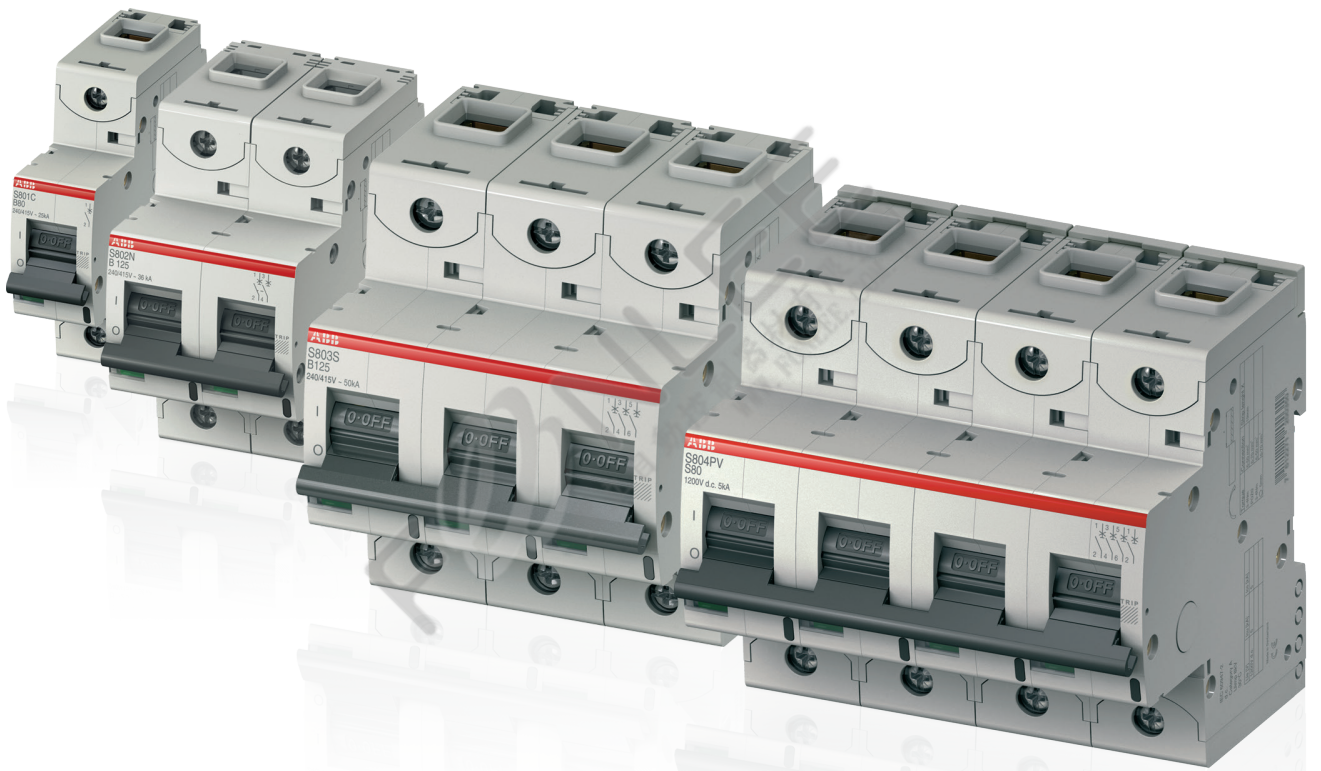



Applications

The range of applications of the S800 high performance circuit breakers is extremely varied: from building and marine installations, industry, transport and renewable energies to uninterrupted power supply. The S800 high performance circuit breakers are reliable switches: rated ultimate short-circuit breaking capacity up to 50 kA, fixed rated tripping current, current rating up to 125A, the most varied of characteristics and much more. S800 are flexible, yet at the same time meet the highest safety requirements. See the variety for yourself!

01 Building installation

02 Industry

03 Renewable energy

04 Transportation

02



03





New products

Highlights

Rated current is now extended to complete the following ranges, covering all the possible industrial applications from 0.5 A to 125 A:

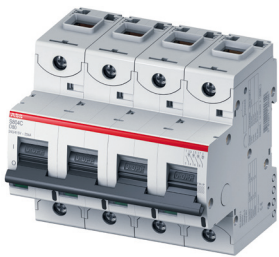

S800S

New rated current:

0.5A, 1A, 1.6A, 2A, 2.5A, 3A, 4A and 5A

Certification:

UL, VDE*, CCC*

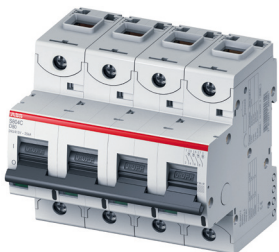

S800S-UC

New rated current:

0.5A, 1A, 1.6A, 2A, 2.5A, 3A, 4A, 5A, 6A and 8A

Certification:

VDE, CCC*

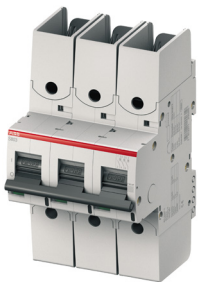

S800HV

New rated current:

0.5A, 1A, 1.6A, 2A, 2.5A, 3A, 4A and 5A

Certification:

CE

*certification under preparation



CIRCUIT MONITORING SYSTEM

CMS – Circuit Monitoring System for S800

The Circuit Monitoring System (CMS) is an ultra-compact multichannel measurement system for AC and DC branch monitoring, fully compatible with S800 high-performance circuit breakers. It represents a complete solution for monitoring electrical parameters in distribution panels, enabling power monitoring and energy efficiency analysis in buildings and critical power applications.

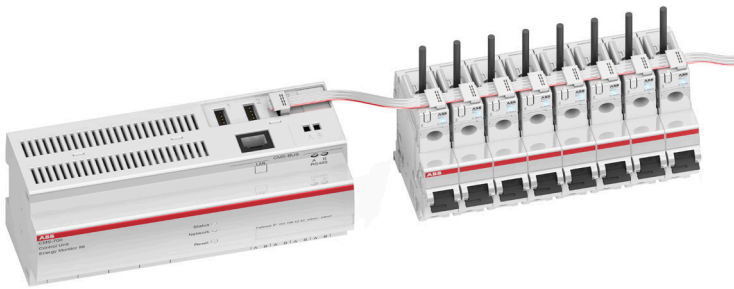

The **CMS-700 control unit** is the reliable solution for maximum transparency of energy consumption, enabling to carry out plug&play energy monitoring. Thanks to its built-in web server, any web browser can be used to carry out the smart commissioning of the system, as well as easy visualization of online and historical measurement data.

CMS System overview

CMS sensors

Sensors can be placed anywhere in the system. One set of sensors is specifically designed for mounting on S800 with cage terminals (except S800B, HV, U-UCZ, U-PVS).

Control Unit

The control unit evaluates the measurement data picked up by the sensors and makes it available via the communication interfaces.

Connection technology

Connecting the sensors to the control unit via CMS Bus requires no special tools.

Benefits

- Clear visibility of energy consumption at branch level
- Easy retrofitting and upgrades
- Maximum reliability and security thanks to encryption
- Simplified installation and commissioning
- One sensor for all types of currents



SMISLINE TP Power Bar System: 400A Incoming, 40kA solution with S800S

The universal adapter with the new 9mm dummy housing is specially designed for the High Performance Circuit Breaker S800. This allows to have a 27mm adapter on the SMISLINE TP busbar system. The S800 High performance MCB can be easily mounted and wired on the universal adapter. The complete unit can be clicked on to the plug-in socket system quickly and safely. The input wiring is then already finished.

Benefits

- Simple mounting S800 MCB on SMISLINE TP system with 27mm wide universal adapter (max rated current of S800 on universal adapter is 50A)
- Max. Incoming 400A (T5/XT5) rated conditional short-circuit current I_{cc} 40kA (415V) with S800S
- Time-saving mounting of S800 MCB units up to 30% faster than conventional DIN rail mounting

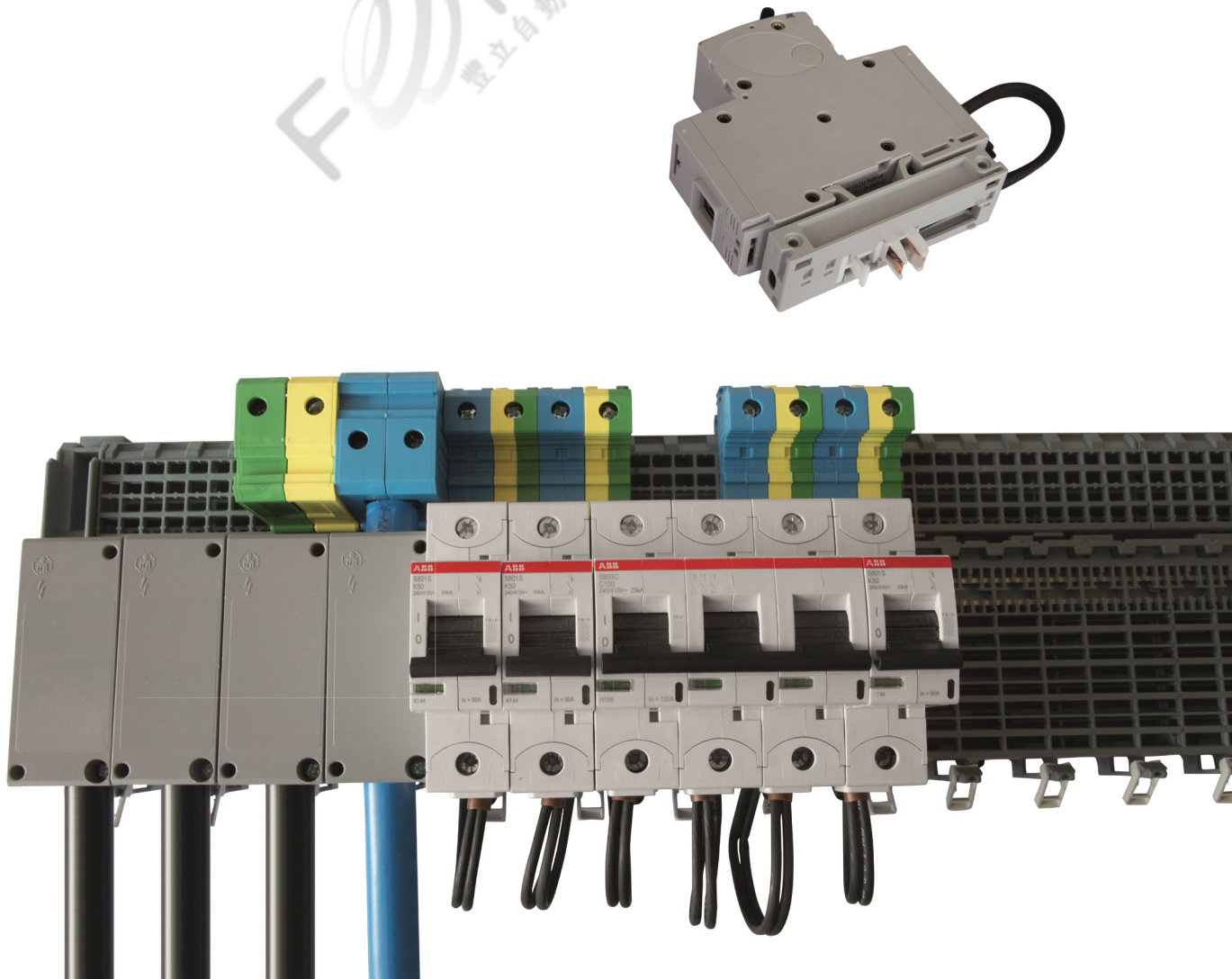

FONLEE
豐立自動控制器材有限公司
www.fonlee.com.tw

S800

S800S-B	1/3
S800S-C	1/5
S800S-D	1/8
S800S-K	1/9
S803S-KM	1/11
S800S-UCB	1/12
S800S-UCK	1/14
S800N-B	1/16
S800N-C	1/18
S800N-D	1/20
S800C-B	1/22
S800C-C	1/23
S800C-D	1/24
S800C-K	1/25
S800B-B	1/26
S800B-C	1/27
S800B-D	1/28
S800B-K	1/29
S800HV-K	1/30
S800HV-C	1/31
S800U-K	1/32
S800U-Z	1/33
S804U-UCZ	1/34
S800PV-SP	1/35
S800PV-SD	1/36
S802PV-M-H	1/37
S804U-PVS	1/38
Accessories	1/39

S800S-B Characteristic B

$I_{cu} = 50 \text{ kA}$; with interchangeable cage terminal



2CCC413001F0002

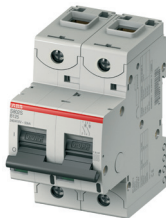

2CCC413002F0002



Number of poles	I_{cu} [kA]	Rated current [A]	GTIN EAN 7612271	Order details		Weight [kg]	Pack. unit
				Type Code	Order code		
1	50	0,5	498979	S801S-B0,5	2CCF019841R0001	0.24	1
	50	1	498986	S801S-B1	2CCF019842R0001	0.24	1
	50	1,6	498993	S801S-B1,6	2CCF019843R0001	0.24	1
	50	2	499105	S801S-B2	2CCF019844R0001	0.24	1
	50	2,5	499112	S801S-B2,5	2CCF019845R0001	0.24	1
	50	3	499129	S801S-B3	2CCF019846R0001	0.24	1
	50	4	499136	S801S-B4	2CCF019847R0001	0.24	1
	50	5	499143	S801S-B5	2CCF019848R0001	0.24	1
	50	6	408107	S801S-B6	2CCS861001R0065	0.24	1
	50	8	411329	S801S-B8	2CCS861001R0085	0.24	1
	50	10	200008	S801S-B10	2CCS861001R0105	0.24	1
	50	13	200015	S801S-B13	2CCS861001R0135	0.24	1
	50	16	200022	S801S-B16	2CCS861001R0165	0.24	1
	50	20	200039	S801S-B20	2CCS861001R0205	0.24	1
	50	25	200046	S801S-B25	2CCS861001R0255	0.24	1
	50	32	200053	S801S-B32	2CCS861001R0325	0.24	1
	50	40	200060	S801S-B40	2CCS861001R0405	0.24	1
	50	50	200077	S801S-B50	2CCS861001R0505	0.24	1
	50	63	200084	S801S-B63	2CCS861001R0635	0.24	1
	50	80	200091	S801S-B80	2CCS861001R0805	0.24	1
	50	100	200107	S801S-B100	2CCS861001R0825	0.24	1
50	125	200114	S801S-B125	2CCS861001R0845	0.24	1	
2	50	0,5	499310	S802S-B0,5	2CCF019865R0001	0.49	1
	50	1	499327	S802S-B1	2CCF019866R0001	0.49	1
	50	1,6	499334	S802S-B1,6	2CCF019867R0001	0.49	1
	50	2	499341	S802S-B2	2CCF019868R0001	0.49	1
	50	2,5	499358	S802S-B2,5	2CCF019869R0001	0.49	1
	50	3	499365	S802S-B3	2CCF019870R0001	0.49	1
	50	4	499372	S802S-B4	2CCF019871R0001	0.49	1
	50	5	499389	S802S-B5	2CCF019872R0001	0.49	1
	0	6	408114	S802S-B6	2CCS862001R0065	0.49	1
	50	8	411336	S802S-B8	2CCS862001R0085	0.49	1
	50	10	200121	S802S-B10	2CCS862001R0105	0.49	1
	50	13	200138	S802S-B13	2CCS862001R0135	0.49	1
	50	16	200145	S802S-B16	2CCS862001R0165	0.49	1
	50	20	200152	S802S-B20	2CCS862001R0205	0.49	1
	50	25	200169	S802S-B25	2CCS862001R0255	0.49	1
	50	32	200176	S802S-B32	2CCS862001R0325	0.49	1
	50	40	200183	S802S-B40	2CCS862001R0405	0.49	1
	50	50	200190	S802S-B50	2CCS862001R0505	0.49	1
	50	63	200206	S802S-B63	2CCS862001R0635	0.49	1
	50	80	200213	S802S-B80	2CCS862001R0805	0.49	1
	50	100	200220	S802S-B100	2CCS862001R0825	0.49	1
50	125	200237	S802S-B125	2CCS862001R0845	0.49	1	

S800S-B Characteristic B

$I_{cu} = 50 \text{ kA}$; with interchangeable cage terminal

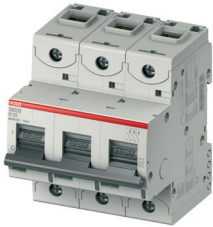

2CCC413003F0002

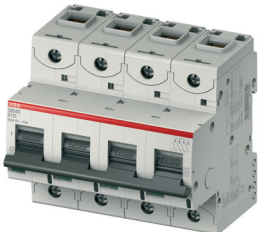

2CCC413004F0002



Number of poles	I_{cu} [kA]	Rated current [A]	GTIN EAN 7612271	Order details		Weight [kg]	Pack. unit
				Type Code	Order code		
3	50	0,5	499556	S803S-B0,5	2CCF019889R0001	0.74	1
	50	1	499563	S803S-B1	2CCF019890R0001	0.74	1
	50	1,6	499570	S803S-B1,6	2CCF019891R0001	0.74	1
	50	2	499587	S803S-B2	2CCF019892R0001	0.74	1
	50	2,5	499594	S803S-B2,5	2CCF019893R0001	0.74	1
	50	3	499600	S803S-B3	2CCF019894R0001	0.74	1
	50	4	499617	S803S-B4	2CCF019895R0001	0.74	1
	50	5	499624	S803S-B5	2CCF019896R0001	0.74	1
	50	6	408121	S803S-B6	2CCS863001R0065	0.74	1
	50	8	411343	S803S-B8	2CCS863001R0085	0.74	1
	50	10	200244	S803S-B10	2CCS863001R0105	0.74	1
	50	13	200251	S803S-B13	2CCS863001R0135	0.74	1
	50	16	200268	S803S-B16	2CCS863001R0165	0.74	1
	50	20	200275	S803S-B20	2CCS863001R0205	0.74	1
	50	25	200282	S803S-B25	2CCS863001R0255	0.74	1
	50	32	200299	S803S-B32	2CCS863001R0325	0.74	1
	50	40	200305	S803S-B40	2CCS863001R0405	0.74	1
	50	50	200312	S803S-B50	2CCS863001R0505	0.74	1
	50	63	200329	S803S-B63	2CCS863001R0635	0.74	1
	50	80	200336	S803S-B80	2CCS863001R0805	0.74	1
50	100	200343	S803S-B100	2CCS863001R0825	0.74	1	
50	125	200350	S803S-B125	2CCS863001R0845	0.74	1	
4	50	0,5	499792	S804S-B0,5	2CCF019913R0001	0.98	1
	50	1	499808	S804S-B1	2CCF019914R0001	0.98	1
	50	1,6	499815	S804S-B1,6	2CCF019915R0001	0.98	1
	50	2	499822	S804S-B2	2CCF019916R0001	0.98	1
	50	2,5	499839	S804S-B2,5	2CCF019917R0001	0.98	1
	50	3	499846	S804S-B3	2CCF019918R0001	0.98	1
	50	4	499853	S804S-B4	2CCF019919R0001	0.98	1
	50	5	499860	S804S-B5	2CCF019920R0001	0.98	1
	50	6	408138	S804S-B6	2CCS864001R0065	0.98	1
	50	8	411350	S804S-B8	2CCS864001R0085	0.98	1
	50	10	200367	S804S-B10	2CCS864001R0105	0.98	1
	50	13	200374	S804S-B13	2CCS864001R0135	0.98	1
	50	16	200381	S804S-B16	2CCS864001R0165	0.98	1
	50	20	200398	S804S-B20	2CCS864001R0205	0.98	1
	50	25	200404	S804S-B25	2CCS864001R0255	0.98	1
	50	32	200411	S804S-B32	2CCS864001R0325	0.98	1
	50	40	200428	S804S-B40	2CCS864001R0405	0.98	1
	50	50	200435	S804S-B50	2CCS864001R0505	0.98	1
	50	63	200442	S804S-B63	2CCS864001R0635	0.98	1
	50	80	200459	S804S-B80	2CCS864001R0805	0.98	1
50	100	200466	S804S-B100	2CCS864001R0825	0.98	1	
50	125	200473	S804S-B125	2CCS864001R0845	0.98	1	

S800S-C Characteristic C

$I_{cu} = 50 \text{ kA}$; with interchangeable cage terminal



2CCC413005F0002



Number of poles	I_{cu} [kA]	Rated current [A]	GTIN EAN 7612271	Order details		Weight [kg]	Pack. unit
				Type Code	Order code		
1	50	0,5	499150	S801S-C0,5	2CCF019849R0001	0.24	1
	50	1	499167	S801S-C1	2CCF019850R0001	0.24	1
	50	1,6	499174	S801S-C1,6	2CCF019851R0001	0.24	1
	50	2	499181	S801S-C2	2CCF019852R0001	0.24	1
	50	2,5	499198	S801S-C2,5	2CCF019853R0001	0.24	1
	50	3	499204	S801S-C3	2CCF019854R0001	0.24	1
	50	4	499211	S801S-C4	2CCF019855R0001	0.24	1
	50	5	499228	S801S-C5	2CCF019856R0001	0.24	1
	50	6	408145	S801S-C6	2CCS861001R0064	0.24	1
	50	8	411367	S801S-C8	2CCS861001R0084	0.24	1
	50	10	200480	S801S-C10	2CCS861001R0104	0.24	1
	50	13	200497	S801S-C13	2CCS861001R0134	0.24	1
	50	16	200503	S801S-C16	2CCS861001R0164	0.24	1
	50	20	200510	S801S-C20	2CCS861001R0204	0.24	1
	50	25	200527	S801S-C25	2CCS861001R0254	0.24	1
	50	32	200534	S801S-C32	2CCS861001R0324	0.24	1
	50	40	200541	S801S-C40	2CCS861001R0404	0.24	1
	50	50	200558	S801S-C50	2CCS861001R0504	0.24	1
	50	63	200565	S801S-C63	2CCS861001R0634	0.24	1
	50	80	200572	S801S-C80	2CCS861001R0804	0.24	1
50	100	200589	S801S-C100	2CCS861001R0824	0.24	1	
50	125	200596	S801S-C125	2CCS861001R0844	0.24	1	
2	50	0,5	499396	S802S-C0,5	2CCF019873R0001	0.49	1
	50	1	499402	S802S-C1	2CCF019874R0001	0.49	1
	50	1,6	499419	S802S-C1,6	2CCF019875R0001	0.49	1
	50	2	499426	S802S-C2	2CCF019876R0001	0.49	1
	50	2,5	499433	S802S-C2,5	2CCF019877R0001	0.49	1
	50	3	499440	S802S-C3	2CCF019878R0001	0.49	1
	50	4	499457	S802S-C4	2CCF019879R0001	0.49	1
	50	5	499464	S802S-C5	2CCF019880R0001	0.49	1
	50	6	408152	S802S-C6	2CCS862001R0064	0.49	1
	50	8	411374	S802S-C8	2CCS862001R0084	0.49	1
	50	10	200602	S802S-C10	2CCS862001R0104	0.49	1
	50	13	200619	S802S-C13	2CCS862001R0134	0.49	1
	50	16	200626	S802S-C16	2CCS862001R0164	0.49	1
	50	20	200633	S802S-C20	2CCS862001R0204	0.49	1
	50	25	200640	S802S-C25	2CCS862001R0254	0.49	1
	50	32	200657	S802S-C32	2CCS862001R0324	0.49	1
	50	40	200664	S802S-C40	2CCS862001R0404	0.49	1
	50	50	200671	S802S-C50	2CCS862001R0504	0.49	1
	50	63	200688	S802S-C63	2CCS862001R0634	0.49	1
	50	80	200695	S802S-C80	2CCS862001R0804	0.49	1
50	100	200701	S802S-C100	2CCS862001R0824	0.49	1	
50	125	200718	S802S-C125	2CCS862001R0844	0.49	1	

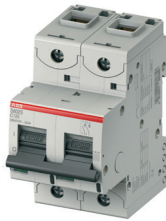

2CCC413006F0002



S800S-C Characteristic C

$I_{cu} = 50 \text{ kA}$; with interchangeable cage terminal



2CCC413007F0002

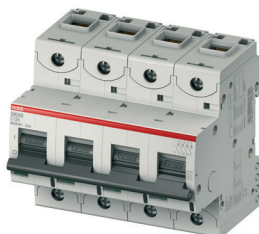

2CCC413008F0002



Number of poles	I_{cu} [kA]	Rated current [A]	GTIN EAN 7612271	Order details		Weight [kg]	Pack. unit
				Type Code	Order code		
3	50	0,5	499631	S803S-C0,5	2CCF019897R0001	0.74	1
	50	1	499648	S803S-C1	2CCF019898R0001	0.74	1
	50	1,6	499655	S803S-C1,6	2CCF019899R0001	0.74	1
	50	2	499662	S803S-C2	2CCF019900R0001	0.74	1
	50	2,5	499679	S803S-C2,5	2CCF019901R0001	0.74	1
	50	3	499686	S803S-C3	2CCF019902R0001	0.74	1
	50	4	499693	S803S-C4	2CCF019903R0001	0.74	1
	50	5	499709	S803S-C5	2CCF019904R0001	0.74	1
	50	6	408169	S803S-C6	2CCS863001R0064	0.74	1
	50	8	411381	S803S-C8	2CCS863001R0084	0.74	1
	50	10	200725	S803S-C10	2CCS863001R0104	0.74	1
	50	13	200732	S803S-C13	2CCS863001R0134	0.74	1
	50	16	200749	S803S-C16	2CCS863001R0164	0.74	1
	50	20	200756	S803S-C20	2CCS863001R0204	0.74	1
	50	25	200763	S803S-C25	2CCS863001R0254	0.74	1
	50	32	200770	S803S-C32	2CCS863001R0324	0.74	1
	50	40	200787	S803S-C40	2CCS863001R0404	0.74	1
	50	50	200794	S803S-C50	2CCS863001R0504	0.74	1
	50	63	200800	S803S-C63	2CCS863001R0634	0.74	1
	50	80	200817	S803S-C80	2CCS863001R0804	0.74	1
50	100	200824	S803S-C100	2CCS863001R0824	0.74	1	
50	125	200831	S803S-C125	2CCS863001R0844	0.74	1	
4	50	0,5	499877	S804S-C0,5	2CCF019921R0001	0.98	1
	50	1	499884	S804S-C1	2CCF019922R0001	0.98	1
	50	1,6	499891	S804S-C1,6	2CCF019923R0001	0.98	1
	50	2	499907	S804S-C2	2CCF019924R0001	0.98	1
	50	2,5	499914	S804S-C2,5	2CCF019925R0001	0.98	1
	50	3	499921	S804S-C3	2CCF019926R0001	0.98	1
	50	4	499938	S804S-C4	2CCF019927R0001	0.98	1
	50	5	499945	S804S-C5	2CCF019928R0001	0.98	1
	50	6	408176	S804S-C6	2CCS864001R0064	0.98	1
	50	8	411398	S804S-C8	2CCS864001R0084	0.98	1
	50	10	200848	S804S-C10	2CCS864001R0104	0.98	1
	50	13	200855	S804S-C13	2CCS864001R0134	0.98	1
	50	16	200862	S804S-C16	2CCS864001R0164	0.98	1
	50	20	200879	S804S-C20	2CCS864001R0204	0.98	1
	50	25	200886	S804S-C25	2CCS864001R0254	0.98	1
	50	32	200893	S804S-C32	2CCS864001R0324	0.98	1
	50	40	200909	S804S-C40	2CCS864001R0404	0.98	1
	50	50	200916	S804S-C50	2CCS864001R0504	0.98	1
	50	63	200923	S804S-C63	2CCS864001R0634	0.98	1
	50	80	200930	S804S-C80	2CCS864001R0804	0.98	1
50	100	200947	S804S-C100	2CCS864001R0824	0.98	1	
50	125	200954	S804S-C125	2CCS864001R0844	0.98	1	

S800S-D Characteristic D

$I_{cu} = 50 \text{ kA}$; with interchangeable cage terminal



2CCC413009F0002



2CCC41300DF0002



Number of poles	I_{cu} [kA]	Rated current [A]	GTIN EAN 7612271	Order details		Weight [kg]	Pack. unit
				Type Code	Order code		
1	50	0,5	499235	S801S-D0,5	2CCF019857R0001	0.24	1
	50	1	499242	S801S-D1	2CCF019858R0001	0.24	1
	50	1,6	499259	S801S-D1,6	2CCF019859R0001	0.24	1
	50	2	499266	S801S-D2	2CCF019860R0001	0.24	1
	50	2,5	499273	S801S-D2,5	2CCF019861R0001	0.24	1
	50	3	499280	S801S-D3	2CCF019862R0001	0.24	1
	50	4	499297	S801S-D4	2CCF019863R0001	0.24	1
	50	5	499303	S801S-D5	2CCF019864R0001	0.24	1
	50	6	408183	S801S-D6	2CCS861001R0061	0.24	1
	50	8	411404	S801S-D8	2CCS861001R0081	0.24	1
	50	10	200961	S801S-D10	2CCS861001R0101	0.24	1
	50	13	200978	S801S-D13	2CCS861001R0131	0.24	1
	50	16	200985	S801S-D16	2CCS861001R0161	0.24	1
	50	20	200992	S801S-D20	2CCS861001R0201	0.24	1
	50	25	201005	S801S-D25	2CCS861001R0251	0.24	1
	50	32	201012	S801S-D32	2CCS861001R0321	0.24	1
	50	40	201029	S801S-D40	2CCS861001R0401	0.24	1
	50	50	201036	S801S-D50	2CCS861001R0501	0.24	1
	50	63	201043	S801S-D63	2CCS861001R0631	0.24	1
	50	80	201050	S801S-D80	2CCS861001R0801	0.24	1
50	100	201067	S801S-D100	2CCS861001R0821	0.24	1	
50	125	201074	S801S-D125	2CCS861001R0841	0.24	1	
2	50	0,5	499471	S802S-D0,5	2CCF019881R0001	0.49	1
	50	1	499488	S802S-D1	2CCF019882R0001	0.49	1
	50	1,6	499495	S802S-D1,6	2CCF019883R0001	0.49	1
	50	2	499501	S802S-D2	2CCF019884R0001	0.49	1
	50	2,5	499518	S802S-D2,5	2CCF019885R0001	0.49	1
	50	3	499525	S802S-D3	2CCF019886R0001	0.49	1
	50	4	499532	S802S-D4	2CCF019887R0001	0.49	1
	50	5	499549	S802S-D5	2CCF019888R0001	0.49	1
	50	6	408190	S802S-D6	2CCS862001R0061	0.49	1
	50	8	411411	S802S-D8	2CCS862001R0081	0.49	1
	50	10	201081	S802S-D10	2CCS862001R0101	0.49	1
	50	13	201098	S802S-D13	2CCS862001R0131	0.49	1
	50	16	201104	S802S-D16	2CCS862001R0161	0.49	1
	50	20	201111	S802S-D20	2CCS862001R0201	0.49	1
	50	25	201128	S802S-D25	2CCS862001R0251	0.49	1
	50	32	201135	S802S-D32	2CCS862001R0321	0.49	1
	50	40	201142	S802S-D40	2CCS862001R0401	0.49	1
	50	50	201159	S802S-D50	2CCS862001R0501	0.49	1
	50	63	201166	S802S-D63	2CCS862001R0631	0.49	1
	50	80	201173	S802S-D80	2CCS862001R0801	0.49	1
50	100	201180	S802S-D100	2CCS862001R0821	0.49	1	
50	125	201197	S802S-D125	2CCS862001R0841	0.49	1	

S800S-D Characteristic D

$I_{cu} = 50 \text{ kA}$; with interchangeable cage terminal

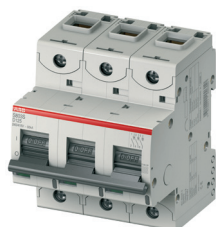

2CCC41301F0002

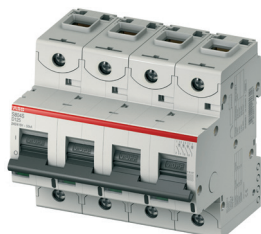

2CCC413012F0002



Number of poles	I_{cu} [kA]	Rated current [A]	GTIN EAN 7612271	Order details		Weight [kg]	Pack. unit
				Type Code	Order code		
3	50	0,5	499716	S803S-D0,5	2CCF019905R0001	0.74	1
	50	1	499723	S803S-D1	2CCF019906R0001	0.74	1
	50	1,6	499730	S803S-D1,6	2CCF019907R0001	0.74	1
	50	2	499747	S803S-D2	2CCF019908R0001	0.74	1
	50	2,5	499754	S803S-D2,5	2CCF019909R0001	0.74	1
	50	3	499761	S803S-D3	2CCF019910R0001	0.74	1
	50	4	499778	S803S-D4	2CCF019911R0001	0.74	1
	50	5	499785	S803S-D5	2CCF019912R0001	0.74	1
	50	6	408206	S803S-D6	2CCS863001R0061	0.74	1
	50	8	411428	S803S-D8	2CCS863001R0081	0.74	1
	50	10	201203	S803S-D10	2CCS863001R0101	0.74	1
	50	13	201210	S803S-D13	2CCS863001R0131	0.74	1
	50	16	201227	S803S-D16	2CCS863001R0161	0.74	1
	50	20	201234	S803S-D20	2CCS863001R0201	0.74	1
	50	25	201241	S803S-D25	2CCS863001R0251	0.74	1
	50	32	201258	S803S-D32	2CCS863001R0321	0.74	1
	50	40	201265	S803S-D40	2CCS863001R0401	0.74	1
	50	50	201272	S803S-D50	2CCS863001R0501	0.74	1
	50	63	201289	S803S-D63	2CCS863001R0631	0.74	1
	50	80	201296	S803S-D80	2CCS863001R0801	0.74	1
50	100	201302	S803S-D100	2CCS863001R0821	0.74	1	
50	125	201319	S803S-D125	2CCS863001R0841	0.74	1	
4	50	0,5	499952	S804S-D0,5	2CCF019929R0001	0.98	1
	50	1	499969	S804S-D1	2CCF019930R0001	0.98	1
	50	1,6	499976	S804S-D1,6	2CCF019931R0001	0.98	1
	50	2	499983	S804S-D2	2CCF019932R0001	0.98	1
	50	2,5	499990	S804S-D2,5	2CCF019933R0001	0.98	1
	50	3	500009	S804S-D3	2CCF019934R0001	0.98	1
	50	4	500016	S804S-D4	2CCF019935R0001	0.98	1
	50	5	500023	S804S-D5	2CCF019936R0001	0.98	1
	50	6	408213	S804S-D6	2CCS864001R0061	0.98	1
	50	8	411435	S804S-D8	2CCS864001R0081	0.98	1
	50	10	201326	S804S-D10	2CCS864001R0101	0.98	1
	50	13	201333	S804S-D13	2CCS864001R0131	0.98	1
	50	16	201340	S804S-D16	2CCS864001R0161	0.98	1
	50	20	201357	S804S-D20	2CCS864001R0201	0.98	1
	50	25	201364	S804S-D25	2CCS864001R0251	0.98	1
	50	32	201371	S804S-D32	2CCS864001R0321	0.98	1
	50	40	201388	S804S-D40	2CCS864001R0401	0.98	1
	50	50	201395	S804S-D50	2CCS864001R0501	0.98	1
	50	63	201401	S804S-D63	2CCS864001R0631	0.98	1
	50	80	201418	S804S-D80	2CCS864001R0801	0.98	1
50	100	201425	S804S-D100	2CCS864001R0821	0.98	1	
50	125	201432	S804S-D125	2CCS864001R0841	0.98	1	

S800S-K Characteristic K

$I_{cu} = 50 \text{ kA}$; with interchangeable cage terminal



2CCC413013F0001

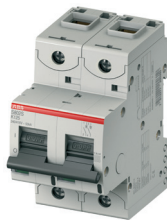

2CCC413014F0001



Number of poles	I_{cu} [kA]	Rated current [A]	GTIN EAN 7612271	Order details		Weight [kg]	Pack. unit
				Type Code	Order code		
1	50	0,5	500030	S801S-K0,5	2CCF019937R0001	0.24	1
	50	1	500047	S801S-K1	2CCF019938R0001	0.24	1
	50	1,6	500054	S801S-K1,6	2CCF019939R0001	0.24	1
	50	2	500061	S801S-K2	2CCF019940R0001	0.24	1
	50	2,5	500078	S801S-K2,5	2CCF019941R0001	0.24	1
	50	3	500085	S801S-K3	2CCF019942R0001	0.24	1
	50	4	500092	S801S-K4	2CCF019943R0001	0.24	1
	50	5	500108	S801S-K5	2CCF019944R0001	0.24	1
	50	6	408220	S801S-K6	2CCS861001R0067	0.24	1
	50	8	411442	S801S-K8	2CCS861001R0407	0.24	1
	50	10	201449	S801S-K10	2CCS861001R0427	0.24	1
	50	13	201456	S801S-K13	2CCS861001R0447	0.24	1
	50	16	201463	S801S-K16	2CCS861001R0467	0.24	1
	50	20	201470	S801S-K20	2CCS861001R0487	0.24	1
	50	25	201487	S801S-K25	2CCS861001R0517	0.24	1
	50	32	201494	S801S-K32	2CCS861001R0537	0.24	1
	50	40	201500	S801S-K40	2CCS861001R0557	0.24	1
	50	50	201517	S801S-K50	2CCS861001R0577	0.24	1
	50	63	201524	S801S-K63	2CCS861001R0597	0.24	1
	50	80	201531	S801S-K80	2CCS861001R0627	0.24	1
50	100	201548	S801S-K100	2CCS861001R0637	0.24	1	
50	125	201555	S801S-K125	2CCS861001R0647	0.24	1	
2	50	0,5	500115	S802S-K0,5	2CCF019945R0001	0.49	1
	50	1	500122	S802S-K1	2CCF019946R0001	0.49	1
	50	1,6	500139	S802S-K1,6	2CCF019947R0001	0.49	1
	50	2	500146	S802S-K2	2CCF019948R0001	0.49	1
	50	2,5	500153	S802S-K2,5	2CCF019949R0001	0.49	1
	50	3	500160	S802S-K3	2CCF019950R0001	0.49	1
	50	4	500177	S802S-K4	2CCF019951R0001	0.49	1
	50	5	500184	S802S-K5	2CCF019952R0001	0.49	1
	50	6	408237	S802S-K6	2CCS862001R0067	0.49	1
	50	8	411459	S802S-K8	2CCS862001R0407	0.49	1
	50	10	201562	S802S-K10	2CCS862001R0427	0.49	1
	50	13	201579	S802S-K13	2CCS862001R0447	0.49	1
	50	16	201586	S802S-K16	2CCS862001R0467	0.49	1
	50	20	201593	S802S-K20	2CCS862001R0487	0.49	1
	50	25	201609	S802S-K25	2CCS862001R0517	0.49	1
	50	32	201616	S802S-K32	2CCS862001R0537	0.49	1
	50	40	201623	S802S-K40	2CCS862001R0557	0.49	1
	50	50	201630	S802S-K50	2CCS862001R0577	0.49	1
	50	63	201647	S802S-K63	2CCS862001R0597	0.49	1
	50	80	201654	S802S-K80	2CCS862001R0627	0.49	1
50	100	201661	S802S-K100	2CCS862001R0637	0.49	1	
50	125	201678	S802S-K125	2CCS862001R0647	0.49	1	

S800S-K Characteristic K

$I_{cu} = 50 \text{ kA}$; with interchangeable cage terminal

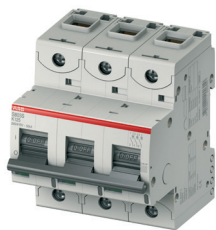

2CCC413015F0001



Number of poles	I_{cu} [kA]	Rated current [A]	GTIN EAN 7612271	Order details		Weight [kg]	Pack. unit
				Type Code	Order code		
3	50	0,5	500191	S803S-K0,5	2CCF019953R0001	0.74	1
	50	1	500207	S803S-K1	2CCF019954R0001	0.74	1
	50	1,6	500214	S803S-K1,6	2CCF019955R0001	0.74	1
	50	2	500221	S803S-K2	2CCF019956R0001	0.74	1
	50	2,5	500238	S803S-K2,5	2CCF019957R0001	0.74	1
	50	3	500245	S803S-K3	2CCF019958R0001	0.74	1
	50	4	500252	S803S-K4	2CCF019959R0001	0.74	1
	50	5	500269	S803S-K5	2CCF019960R0001	0.74	1
	50	6	408244	S803S-K6	2CCS863001R0067	0.74	1
	50	8	411466	S803S-K8	2CCS863001R0407	0.74	1
	50	10	201685	S803S-K10	2CCS863001R0427	0.74	1
	50	13	201692	S803S-K13	2CCS863001R0447	0.74	1
	50	16	201708	S803S-K16	2CCS863001R0467	0.74	1
	50	20	201715	S803S-K20	2CCS863001R0487	0.74	1
	50	25	201722	S803S-K25	2CCS863001R0517	0.74	1
	50	32	201739	S803S-K32	2CCS863001R0537	0.74	1
	50	40	201746	S803S-K40	2CCS863001R0557	0.74	1
	50	50	201753	S803S-K50	2CCS863001R0577	0.74	1
	50	63	201760	aS803S-K63	2CCS863001R0597	0.74	1
	50	80	201777	S803S-K80	2CCS863001R0627	0.74	1
50	100	201784	S803S-K100	2CCS863001R0637	0.74	1	
50	125	201791	S803S-K125	2CCS863001R0647	0.74	1	
4	50	0,5	500276	S804S-K0,5	2CCF019961R0001	0.98	1
	50	1	500283	S804S-K1	2CCF019962R0001	0.98	1
	50	1,6	500290	S804S-K1,6	2CCF019963R0001	0.98	1
	50	2	500306	S804S-K2	2CCF019964R0001	0.98	1
	50	2,5	500313	S804S-K2,5	2CCF019965R0001	0.98	1
	50	3	500320	S804S-K3	2CCF019966R0001	0.98	1
	50	4	500337	S804S-K4	2CCF019967R0001	0.98	1
	50	5	500344	S804S-K5	2CCF019968R0001	0.98	1
	50	6	408251	S804S-K6	2CCS864001R0067	0.98	1
	50	8	411473	S804S-K8	2CCS864001R0407	0.98	1
	50	10	201807	S804S-K10	2CCS864001R0427	0.98	1
	50	13	201814	S804S-K13	2CCS864001R0447	0.98	1
	50	16	201821	S804S-K16	2CCS864001R0467	0.98	1
	50	20	201838	S804S-K20	2CCS864001R0487	0.98	1
	50	25	201845	S804S-K25	2CCS864001R0517	0.98	1
	50	32	201852	S804S-K32	2CCS864001R0537	0.98	1
	50	40	201869	S804S-K40	2CCS864001R0557	0.98	1
	50	50	201876	S804S-K50	2CCS864001R0577	0.98	1
	50	63	201883	S804S-K63	2CCS864001R0597	0.98	1
	50	80	201890	S804S-K80	2CCS864001R0627	0.98	1
50	100	201906	S804S-K100	2CCS864001R0637	0.98	1	
50	125	201913	S804S-K125	2CCS864001R0647	0.98	1	

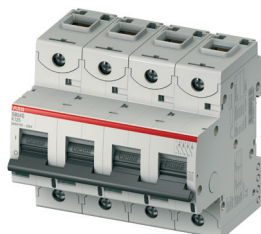

2CCC413016F0001



S803S-KM Characteristic KM*

$I_{cu} = 50 \text{ kA}$; with interchangeable cage terminal



2CCC413017F0001



Number of poles	I_{cu} [kA]	Rated current [A]	GTIN EAN 76122712	Order details		Weight [kg]	Pack. unit
				Type Code	Order code		
3	50	10	41104	S803S-KM10	2CCF019559R0001	0.74	1
	50	16	41111	S803S-KM16	2CCF019560R0001	0.74	1
	50	20	02194	S803S-KM20	2CCS863001R0486	0.74	1
	50	25	02200	S803S-KM25	2CCS863001R0516	0.74	1
	50	32	02217	S803S-KM32	2CCS863001R0536	0.74	1
	50	40	02224	S803S-KM40	2CCS863001R0556	0.74	1
	50	50	02231	S803S-KM50	2CCS863001R0576	0.74	1
	50	63	02248	S803S-KM63	2CCS863001R0596	0.74	1
	50	80	02255	S803S-KM80	2CCS863001R0626	0.74	1

*M stands for magnetic tripping only

FONLEE
豐立自動控制器材有限公司
WWW.FONLEE.COM.TW

S800S-UCB Characteristic B*

$I_{cu} = 50 \text{ kA}$; with interchangeable cage terminal



2CCC413223F0001



2CCC413224F0001



Number of poles	I_{cu} [kA]	Rated current [A]	GTIN EAN 76122712	Order details		Weight [kg]	Pack. unit
				Type Code	Order code		
1	50	0,5	500351	S801S-UCB0,5	2CCF019969R0001	0.24	1
	50	1	500368	S801S-UCB1	2CCF019970R0001	0.24	1
	50	1,6	500375	S801S-UCB1,6	2CCF019971R0001	0.24	1
	50	2	500382	S801S-UCB2	2CCF019972R0001	0.24	1
	50	2,5	500399	S801S-UCB2,5	2CCF019973R0001	0.24	1
	50	3	500405	S801S-UCB3	2CCF019974R0001	0.24	1
	50	4	500412	S801S-UCB4	2CCF019975R0001	0.24	1
	50	5	500429	S801S-UCB5	2CCF019976R0001	0.24	1
	50	6	500436	S801S-UCB6	2CCF019977R0001	0.24	1
	50	8	500443	S801S-UCB8	2CCF019978R0001	0.24	1
	50	10	02842	S801S-UCB10	2CCS861001R1105	0.24	1
	50	13	02859	S801S-UCB13	2CCS861001R1135	0.24	1
	50	16	02866	S801S-UCB16	2CCS861001R1165	0.24	1
	50	20	02873	S801S-UCB20	2CCS861001R1205	0.24	1
	50	25	02880	S801S-UCB25	2CCS861001R1255	0.24	1
	50	32	02897	S801S-UCB32	2CCS861001R1325	0.24	1
	50	40	02903	S801S-UCB40	2CCS861001R1405	0.24	1
	50	50	02910	S801S-UCB50	2CCS861001R1505	0.24	1
	50	63	02927	S801S-UCB63	2CCS861001R1635	0.24	1
	50	80	02934	S801S-UCB80	2CCS861001R1805	0.24	1
50	100	02941	S801S-UCB100	2CCS861001R1825	0.24	1	
50	125	02958	S801S-UCB125	2CCS861001R1845	0.24	1	
2	50	0,5	500559	S802S-UCB0,5	2CCF019989R0001	0.49	1
	50	1	500566	S802S-UCB1	2CCF019990R0001	0.49	1
	50	1,6	500573	S802S-UCB1,6	2CCF019991R0001	0.49	1
	50	2	500580	S802S-UCB2	2CCF019992R0001	0.49	1
	50	2,5	500597	S802S-UCB2,5	2CCF019993R0001	0.49	1
	50	3	500603	S802S-UCB3	2CCF019994R0001	0.49	1
	50	4	500610	S802S-UCB4	2CCF019995R0001	0.49	1
	50	5	500627	S802S-UCB5	2CCF019996R0001	0.49	1
	50	6	500634	S802S-UCB6	2CCF019997R0001	0.49	1
	50	8	500641	S802S-UCB8	2CCF019998R0001	0.49	1
	50	10	02965	S802S-UCB10	2CCS862001R1105	0.49	1
	50	13	02972	S802S-UCB13	2CCS862001R1135	0.49	1
	50	16	02989	S802S-UCB16	2CCS862001R1165	0.49	1
	50	20	02996	S802S-UCB20	2CCS862001R1205	0.49	1
	50	25	03009	S802S-UCB25	2CCS862001R1255	0.49	1
	50	32	03016	S802S-UCB32	2CCS862001R1325	0.49	1
	50	40	03023	S802S-UCB40	2CCS862001R1405	0.49	1
	50	50	03030	S802S-UCB50	2CCS862001R1505	0.49	1
	50	63	03047	S802S-UCB63	2CCS862001R1635	0.49	1
	50	80	03054	S802S-UCB80	2CCS862001R1805	0.49	1
50	100	03061	S802S-UCB100	2CCS862001R1825	0.49	1	
50	125	03078	S802S-UCB125	2CCS862001R1845	0.49	1	

*For DC applications

S800S-UCB Characteristic B*

$I_{cu} = 50 \text{ kA}$; with interchangeable cage terminal

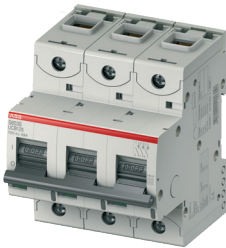

2CCC41322BF0001

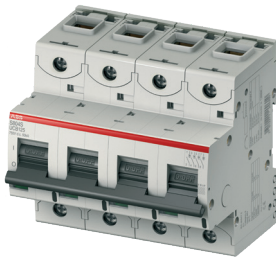

2CCC41322BF0001



Number of poles	I_{cu} [kA]	Rated current [A]	GTIN EAN 7612271	Order details		Weight [kg]	Pack. unit
				Type Code	Order code		
3	50	0,5	502713	S803S-UCB0,5	2CCF030040R0001	0.74	1
	50	1	502720	S803S-UCB1	2CCF030041R0001	0.74	1
	50	1,6	502874	S803S-UCB1,6	2CCF030056R0001	0.74	1
	50	2	502737	S803S-UCB2	2CCF030042R0001	0.74	1
	50	2,5	502744	S803S-UCB2,5	2CCF030043R0001	0.74	1
	50	3	502881	S803S-UCB3	2CCF030057R0001	0.74	1
	50	4	502751	S803S-UCB4	2CCF030044R0001	0.74	1
	50	5	502768	S803S-UCB5	2CCF030045R0001	0.74	1
	50	6	502898	S803S-UCB6	2CCF030058R0001	0.74	1
	50	8	500849	S803S-UCB8	2CCF020018R0001	0.74	1
	50	10	203085	S803S-UCB10	2CCS863001R1105	0.74	1
	50	13	203092	S803S-UCB13	2CCS863001R1135	0.74	1
	50	16	203108	S803S-UCB16	2CCS863001R1165	0.74	1
	50	20	203115	S803S-UCB20	2CCS863001R1205	0.74	1
	50	25	203122	S803S-UCB25	2CCS863001R1255	0.74	1
	50	32	203139	S803S-UCB32	2CCS863001R1325	0.74	1
	50	40	203146	S803S-UCB40	2CCS863001R1405	0.74	1
	50	50	203153	S803S-UCB50	2CCS863001R1505	0.74	1
	50	63	203160	S803S-UCB63	2CCS863001R1635	0.74	1
	50	80	203177	S803S-UCB80	2CCS863001R1805	0.74	1
50	100	203184	S803S-UCB100	2CCS863001R1825	0.74	1	
50	125	203191	S803S-UCB125	2CCS863001R1845	0.74	1	
4	50	0,5	500955	S804S-UCB0,5	2CCF020029R0001	0.98	1
	50	1	500962	S804S-UCB1	2CCF020030R0001	0.98	1
	50	1,6	500979	S804S-UCB1,6	2CCF020031R0001	0.98	1
	50	2	500986	S804S-UCB2	2CCF020032R0001	0.98	1
	50	2,5	500993	S804S-UCB2,5	2CCF020033R0001	0.98	1
	50	3	501006	S804S-UCB3	2CCF020034R0001	0.98	1
	50	4	501013	S804S-UCB4	2CCF020035R0001	0.98	1
	50	5	502775	S804S-UCB5	2CCF030046R0001	0.98	1
	50	6	502782	S804S-UCB6	2CCF030047R0001	0.98	1
	50	8	502904	S804S-UCB8	2CCF030059R0001	0.98	1
	50	10	203207	S804S-UCB10	2CCS864001R1105	0.98	1
	50	13	203214	S804S-UCB13	2CCS864001R1135	0.98	1
	50	16	203221	S804S-UCB16	2CCS864001R1165	0.98	1
	50	20	203238	S804S-UCB20	2CCS864001R1205	0.98	1
	50	25	203245	S804S-UCB25	2CCS864001R1255	0.98	1
	50	32	203252	S804S-UCB32	2CCS864001R1325	0.98	1
	50	40	203269	S804S-UCB40	2CCS864001R1405	0.98	1
	50	50	203276	S804S-UCB50	2CCS864001R1505	0.98	1
	50	63	203283	S804S-UCB63	2CCS864001R1635	0.98	1
	50	80	203290	S804S-UCB80	2CCS864001R1805	0.98	1
50	100	203306	S804S-UCB100	2CCS864001R1825	0.98	1	
50	125	203313	S804S-UCB125	2CCS864001R1845	0.98	1	

*For DC applications

S800S-UCK Characteristic K*

$I_{cu} = 50 \text{ kA}$; with interchangeable cage terminal



2CCC413227F0001

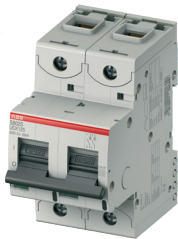

2CCC413228F0001



Number of poles	I_{cu} [kA]	Rated current [A]	GTIN EAN 7612271	Order details		Weight [kg]	Pack. unit
				Type Code	Order code		
1	50	0,5	500450	S801S-UCK0,5	2CCF019979R0001	0.24	1
	50	1	500467	S801S-UCK1	2CCF019980R0001	0.24	1
	50	1,6	500474	S801S-UCK1,6	2CCF019981R0001	0.24	1
	50	2	500481	S801S-UCK2	2CCF019982R0001	0.24	1
	50	2,5	500498	S801S-UCK2,5	2CCF019983R0001	0.24	1
	50	3	500504	S801S-UCK3	2CCF019984R0001	0.24	1
	50	4	500511	S801S-UCK4	2CCF019985R0001	0.24	1
	50	5	500528	S801S-UCK5	2CCF019986R0001	0.24	1
	50	6	500535	S801S-UCK6	2CCF019987R0001	0.24	1
	50	8	500542	S801S-UCK8	2CCF019988R0001	0.24	1
	50	10	203320	S801S-UCK10	2CCS861001R1427	0.24	1
	50	13	203337	S801S-UCK13	2CCS861001R1447	0.24	1
	50	16	203344	S801S-UCK16	2CCS861001R1467	0.24	1
	50	20	203351	S801S-UCK20	2CCS861001R1487	0.24	1
	50	25	203368	S801S-UCK25	2CCS861001R1517	0.24	1
	50	32	203375	S801S-UCK32	2CCS861001R1537	0.24	1
	50	40	203382	S801S-UCK40	2CCS861001R1557	0.24	1
	50	50	203399	S801S-UCK50	2CCS861001R1577	0.24	1
	50	63	203405	S801S-UCK63	2CCS861001R1597	0.24	1
	50	80	203412	S801S-UCK80	2CCS861001R1627	0.24	1
50	100	203429	S801S-UCK100	2CCS861001R1637	0.24	1	
50	125	203436	S801S-UCK125	2CCS861001R1647	0.24	1	
2	50	0,5	500658	S802S-UCK0,5	2CCF019999R0001	0.49	1
	50	1	502652	S802S-UCK1	2CCF030034R0001	0.49	1
	50	1,6	502669	S802S-UCK1,6	2CCF030035R0001	0.49	1
	50	2	502843	S802S-UCK2	2CCF030053R0001	0.49	1
	50	2,5	502676	S802S-UCK2,5	2CCF030036R0001	0.49	1
	50	3	502683	S802S-UCK3	2CCF030037R0001	0.49	1
	50	4	502850	S802S-UCK4	2CCF030054R0001	0.49	1
	50	5	502690	S802S-UCK5	2CCF030038R0001	0.49	1
	50	6	502706	S802S-UCK6	2CCF030039R0001	0.49	1
	50	8	502867	S802S-UCK8	2CCF030055R0001	0.49	1
	50	10	203443	S802S-UCK10	2CCS862001R1427	0.49	1
	50	13	203450	S802S-UCK13	2CCS862001R1447	0.49	1
	50	16	203467	S802S-UCK16	2CCS862001R1467	0.49	1
	50	20	203474	S802S-UCK20	2CCS862001R1487	0.49	1
	50	25	203481	S802S-UCK25	2CCS862001R1517	0.49	1
	50	32	203498	S802S-UCK32	2CCS862001R1537	0.49	1
	50	40	203504	S802S-UCK40	2CCS862001R1557	0.49	1
	50	50	203511	S802S-UCK50	2CCS862001R1577	0.49	1
	50	63	203528	S802S-UCK63	2CCS862001R1597	0.49	1
	50	80	203535	S802S-UCK80	2CCS862001R1627	0.49	1
50	100	203542	S802S-UCK100	2CCS862001R1637	0.49	1	
50	125	203559	S802S-UCK125	2CCS862001R1647	0.49	1	

*For DC applications

S800S-UCK Characteristic K*

$I_{cu} = 50 \text{ kA}$; with interchangeable cage terminal

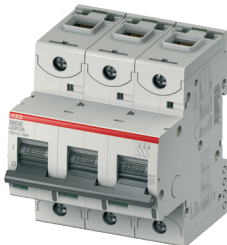

2CCC413225F0001

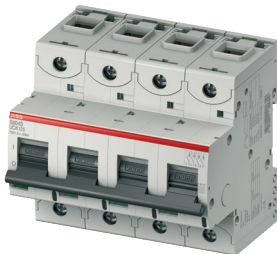

2CCC413230F0001



Number of poles	I_{cu} [kA]	Rated current [A]	GTIN EAN 7612271	Order details		Weight [kg]	Pack. unit
				Type Code	Order code		
3	50	0,5	500856	S803S-UCK0,5	2CCF020019R0001	0.74	1
	50	1	500863	S803S-UCK1	2CCF020020R0001	0.74	1
	50	1,6	500870	S803S-UCK1,6	2CCF020021R0001	0.74	1
	50	2	500887	S803S-UCK2	2CCF020022R0001	0.74	1
	50	2,5	500894	S803S-UCK2,5	2CCF020023R0001	0.74	1
	50	3	500900	S803S-UCK3	2CCF020024R0001	0.74	1
	50	4	500917	S803S-UCK4	2CCF020025R0001	0.74	1
	50	5	500924	S803S-UCK5	2CCF020026R0001	0.74	1
	50	6	500931	S803S-UCK6	2CCF020027R0001	0.74	1
	50	8	500948	S803S-UCK8	2CCF020028R0001	0.74	1
	50	10	203566	S803S-UCK10	2CCS863001R1427	0.74	1
	50	13	203573	S803S-UCK13	2CCS863001R1447	0.74	1
	50	16	203580	S803S-UCK16	2CCS863001R1467	0.74	1
	50	20	203597	S803S-UCK20	2CCS863001R1487	0.74	1
	50	25	203603	S803S-UCK25	2CCS863001R1517	0.74	1
	50	32	203610	S803S-UCK32	2CCS863001R1537	0.74	1
	50	40	203627	S803S-UCK40	2CCS863001R1557	0.74	1
	50	50	203634	S803S-UCK50	2CCS863001R1577	0.74	1
	50	63	203641	S803S-UCK63	2CCS863001R1597	0.74	1
	50	80	203658	S803S-UCK80	2CCS863001R1627	0.74	1
50	100	203665	S803S-UCK100	2CCS863001R1637	0.74	1	
50	125	203672	S803S-UCK125	2CCS863001R1647	0.74	1	
4	50	0,5	502799	S804S-UCK0,5	2CCF030048R0001	0.98	1
	50	1	502805	S804S-UCK1	2CCF030049R0001	0.98	1
	50	1,6	502911	S804S-UCK1,6	2CCF030060R0001	0.98	1
	50	2	502812	S804S-UCK2	2CCF030050R0001	0.98	1
	50	2,5	502829	S804S-UCK2,5	2CCF030051R0001	0.98	1
	50	3	502928	S804S-UCK3	2CCF030061R0001	0.98	1
	50	4	502836	S804S-UCK4	2CCF030052R0001	0.98	1
	50	5	502416	S804S-UCK5	2CCF030020R0001	0.98	1
	50	6	502607	S804S-UCK6	2CCF030029R0001	0.98	1
	50	8	501143	S804S-UCK8	2CCF020048R0001	0.98	1
	50	10	203689	S804S-UCK10	2CCS864001R1427	0.98	1
	50	13	203696	S804S-UCK13	2CCS864001R1447	0.98	1
	50	16	203702	S804S-UCK16	2CCS864001R1467	0.98	1
	50	20	203719	S804S-UCK20	2CCS864001R1487	0.98	1
	50	25	203726	S804S-UCK25	2CCS864001R1517	0.98	1
	50	32	203733	S804S-UCK32	2CCS864001R1537	0.98	1
	50	40	203740	S804S-UCK40	2CCS864001R1557	0.98	1
	50	50	203757	S804S-UCK50	2CCS864001R1577	0.98	1
	50	63	203764	S804S-UCK63	2CCS864001R1597	0.98	1
	50	80	203771	S804S-UCK80	2CCS864001R1627	0.98	1
50	100	203788	S804S-UCK100	2CCS864001R1637	0.98	1	
50	125	203795	S804S-UCK125	2CCS864001R1647	0.98	1	

*For DC applications

S800N-B Characteristic B

$I_{cu} = 36 \text{ kA}$; with interchangeable cage terminal



2CCC413028F0001

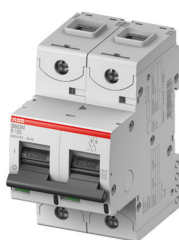

2CCC413027F0001

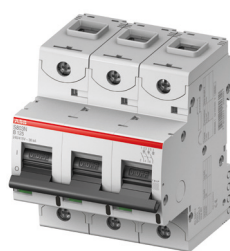

2CCC413028F0001



Number of poles	I_{cu} [kA]	Rated current [A]	GTIN EAN 7612271	Order details		Weight [kg]	Pack. unit
				Type Code	Order code		
1	36	6	408428	S801N-B6	2CCS891001R0065	0.24	1
	36	8	411640	S801N-B8	2CCS891001R0085	0.24	1
	36	10	203801	S801N-B10	2CCS891001R0105	0.24	1
	36	13	203818	S801N-B13	2CCS891001R0135	0.24	1
	36	16	203825	S801N-B16	2CCS891001R0165	0.24	1
	36	20	203832	S801N-B20	2CCS891001R0205	0.24	1
	36	25	203849	S801N-B25	2CCS891001R0255	0.24	1
	36	32	203856	S801N-B32	2CCS891001R0325	0.24	1
	36	40	203863	S801N-B40	2CCS891001R0405	0.24	1
	36	50	203870	S801N-B50	2CCS891001R0505	0.24	1
	36	63	203887	S801N-B63	2CCS891001R0635	0.24	1
	36	80	203894	S801N-B80	2CCS891001R0805	0.24	1
	36	100	203900	S801N-B100	2CCS891001R0825	0.24	1
	36	125	203917	S801N-B125	2CCS891001R0845	0.24	1
2	36	6	408435	S802N-B6	2CCS892001R0065	0.48	1
	36	8	411657	S802N-B8	2CCS892001R0085	0.48	1
	36	10	203924	S802N-B10	2CCS892001R0105	0.48	1
	36	13	203931	S802N-B13	2CCS892001R0135	0.48	1
	36	16	203948	S802N-B16	2CCS892001R0165	0.48	1
	36	20	203955	S802N-B20	2CCS892001R0205	0.48	1
	36	25	203962	S802N-B25	2CCS892001R0255	0.48	1
	36	32	203979	S802N-B32	2CCS892001R0325	0.48	1
	36	40	203986	S802N-B40	2CCS892001R0405	0.48	1
	36	50	203993	S802N-B50	2CCS892001R0505	0.48	1
	36	63	204006	S802N-B63	2CCS892001R0635	0.48	1
	36	80	204013	S802N-B80	2CCS892001R0805	0.48	1
	36	100	204020	S802N-B100	2CCS892001R0825	0.48	1
	36	125	204037	S802N-B125	2CCS892001R0845	0.48	1
3	36	6	408442	S803N-B6	2CCS893001R0065	0.72	1
	36	8	411664	S803N-B8	2CCS893001R0085	0.72	1
	36	10	204044	S803N-B10	2CCS893001R0105	0.72	1
	36	13	204051	S803N-B13	2CCS893001R0135	0.72	1
	36	16	204068	S803N-B16	2CCS893001R0165	0.72	1
	36	20	204075	S803N-B20	2CCS893001R0205	0.72	1
	36	25	204082	S803N-B25	2CCS893001R0255	0.72	1
	36	32	204099	S803N-B32	2CCS893001R0325	0.72	1
	36	40	204105	S803N-B40	2CCS893001R0405	0.72	1
	36	50	204112	S803N-B50	2CCS893001R0505	0.72	1
	36	63	204129	S803N-B63	2CCS893001R0635	0.72	1
	36	80	204136	S803N-B80	2CCS893001R0805	0.72	1
	36	100	204143	S803N-B100	2CCS893001R0825	0.72	1
	36	125	204150	S803N-B125	2CCS893001R0845	0.72	1

S800N-B Characteristic B

$I_{cu} = 36 \text{ kA}$; with interchangeable cage terminal

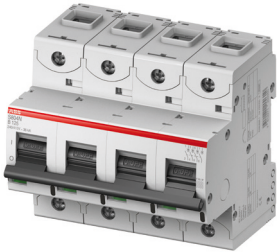

2CC413029F0001



Number of poles	I_{cu} [kA]	Rated current [A]	GTIN EAN 7612271	Order details		Weight [kg]	Pack. unit
				Type Code	Order code		
4	36	6	408459	S804N-B6	2CCS894001R0065	0.96	1
	36	8	411671	S804N-B8	2CCS894001R0085	0.96	1
	36	10	204167	S804N-B10	2CCS894001R0105	0.96	1
	36	13	204174	S804N-B13	2CCS894001R0135	0.96	1
	36	16	204181	S804N-B16	2CCS894001R0165	0.96	1
	36	20	204198	S804N-B20	2CCS894001R0205	0.96	1
	36	25	204204	S804N-B25	2CCS894001R0255	0.96	1
	36	32	204211	S804N-B32	2CCS894001R0325	0.96	1
	36	40	204228	S804N-B40	2CCS894001R0405	0.96	1
	36	50	204235	S804N-B50	2CCS894001R0505	0.96	1
	36	63	204242	S804N-B63	2CCS894001R0635	0.96	1
	36	80	204259	S804N-B80	2CCS894001R0805	0.96	1
	36	100	204266	S804N-B100	2CCS894001R0825	0.96	1
	36	125	204273	S804N-B125	2CCS894001R0845	0.96	1

FONLEE
豐立自動控制器材有限公司
www.fonlee.com.tw

S800N-C Characteristic C

$I_{cu} = 36 \text{ kA}$; with interchangeable cage terminal



2CCC41303F0001

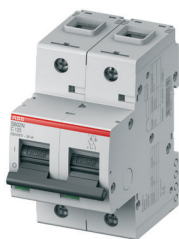

2CCC41303F0001

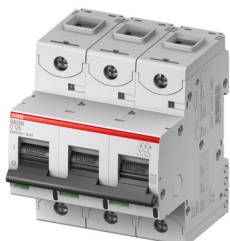

2CCC41303F0001



Number of poles	I_{cu} [kA]	Rated current [A]	GTIN EAN 7612271	Order details		Weight [kg]	Pack. unit
				Type Code	Order code		
1	36	6	408466	S801N-C6	2CCS891001R0064	0.24	1
	36	8	411688	S801N-C8	2CCS891001R0084	0.24	1
	36	10	204280	S801N-C10	2CCS891001R0104	0.24	1
	36	13	204297	S801N-C13	2CCS891001R0134	0.24	1
	36	16	204303	S801N-C16	2CCS891001R0164	0.24	1
	36	20	204310	S801N-C20	2CCS891001R0204	0.24	1
	36	25	204327	S801N-C25	2CCS891001R0254	0.24	1
	36	32	204334	S801N-C32	2CCS891001R0324	0.24	1
	36	40	204341	S801N-C40	2CCS891001R0404	0.24	1
	36	50	204358	S801N-C50	2CCS891001R0504	0.24	1
	36	63	204365	S801N-C63	2CCS891001R0634	0.24	1
	36	80	204372	S801N-C80	2CCS891001R0804	0.24	1
	36	100	204389	S801N-C100	2CCS891001R0824	0.24	1
	36	125	204396	S801N-C125	2CCS891001R0844	0.24	1
2	36	6	408473	S802N-C6	2CCS892001R0064	0.48	1
	36	8	411695	S802N-C8	2CCS892001R0084	0.48	1
	36	10	204402	S802N-C10	2CCS892001R0104	0.48	1
	36	13	204419	S802N-C13	2CCS892001R0134	0.48	1
	36	16	204426	S802N-C16	2CCS892001R0164	0.48	1
	36	20	204433	S802N-C20	2CCS892001R0204	0.48	1
	36	25	204440	S802N-C25	2CCS892001R0254	0.48	1
	36	32	204457	S802N-C32	2CCS892001R0324	0.48	1
	36	40	204464	S802N-C40	2CCS892001R0404	0.48	1
	36	50	204471	S802N-C50	2CCS892001R0504	0.48	1
	36	63	204488	S802N-C63	2CCS892001R0634	0.48	1
	36	80	204495	S802N-C80	2CCS892001R0804	0.48	1
	36	100	204501	S802N-C100	2CCS892001R0824	0.48	1
	36	125	204518	S802N-C125	2CCS892001R0844	0.48	1
3	36	6	408480	S803N-C6	2CCS893001R0064	0.72	1
	36	8	411701	S803N-C8	2CCS893001R0084	0.72	1
	36	10	204525	S803N-C10	2CCS893001R0104	0.72	1
	36	13	204532	S803N-C13	2CCS893001R0134	0.72	1
	36	16	204549	S803N-C16	2CCS893001R0164	0.72	1
	36	20	204556	S803N-C20	2CCS893001R0204	0.72	1
	36	25	204563	S803N-C25	2CCS893001R0254	0.72	1
	36	32	204570	S803N-C32	2CCS893001R0324	0.72	1
	36	40	204587	S803N-C40	2CCS893001R0404	0.72	1
	36	50	204594	S803N-C50	2CCS893001R0504	0.72	1
	36	63	204600	S803N-C63	2CCS893001R0634	0.72	1
	36	80	204617	S803N-C80	2CCS893001R0804	0.72	1
	36	100	204624	S803N-C100	2CCS893001R0824	0.72	1
	36	125	204631	S803N-C125	2CCS893001R0844	0.72	1

S800N-C Characteristic C

$I_{cu} = 36 \text{ kA}$; with interchangeable cage terminal

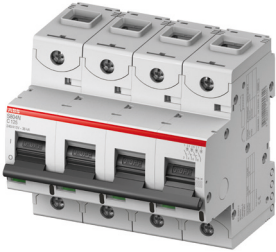

2CCS894001R0001



Number of poles	I_{cu} [kA]	Rated current [A]	GTIN EAN 7612271	Order details		Weight [kg]	Pack. unit
				Type Code	Order code		
1	36	6	408497	S804N-C6	2CCS894001R0064	0.96	1
	36	8	411718	S804N-C8	2CCS894001R0084	0.96	1
	36	10	204648	S804N-C10	2CCS894001R0104	0.96	1
	36	13	204655	S804N-C13	2CCS894001R0134	0.96	1
	36	16	204662	S804N-C16	2CCS894001R0164	0.96	1
	36	20	204679	S804N-C20	2CCS894001R0204	0.96	1
	36	25	204686	S804N-C25	2CCS894001R0254	0.96	1
	36	32	204693	S804N-C32	2CCS894001R0324	0.96	1
	36	40	204709	S804N-C40	2CCS894001R0404	0.96	1
	36	50	204716	S804N-C50	2CCS894001R0504	0.96	1
	36	63	204723	S804N-C63	2CCS894001R0634	0.96	1
	36	80	204730	S804N-C80	2CCS894001R0804	0.96	1
	36	100	204747	S804N-C100	2CCS894001R0824	0.96	1
	36	125	204754	S804N-C125	2CCS894001R0844	0.96	1

FONLEE
豐立自動控制器材有限公司
www.fonlee.com.tw

S800N-D Characteristic D

$I_{cu} = 36 \text{ kA}$; with interchangeable cage terminal



2CCC413034F0001

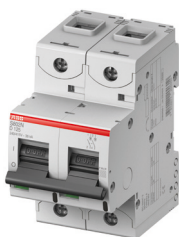

2CCC413035F0001

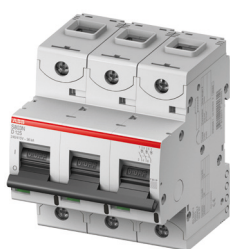

2CCC413036F0001



Number of poles	I_{cu} [kA]	Rated current [A]	GTIN EAN 7612271	Order details		Weight [kg]	Pack. unit
				Type Code	Order code		
1	36	6	408503	S801N-D6	2CCS891001R0061	0.24	1
	36	8	411725	S801N-D8	2CCS891001R0081	0.24	1
	36	10	204761	S801N-D10	2CCS891001R0101	0.24	1
	36	13	204778	S801N-D13	2CCS891001R0131	0.24	1
	36	16	204785	S801N-D16	2CCS891001R0161	0.24	1
	36	20	204792	S801N-D20	2CCS891001R0201	0.24	1
	36	25	204808	S801N-D25	2CCS891001R0251	0.24	1
	36	32	204815	S801N-D32	2CCS891001R0321	0.24	1
	36	40	204822	S801N-D40	2CCS891001R0401	0.24	1
	36	50	204839	S801N-D50	2CCS891001R0501	0.24	1
	36	63	204846	S801N-D63	2CCS891001R0631	0.24	1
	36	80	204853	S801N-D80	2CCS891001R0801	0.24	1
	36	100	204860	S801N-D100	2CCS891001R0821	0.24	1
	36	125	204877	S801N-D125	2CCS891001R0841	0.24	1
2	36	6	408510	S802N-D6	2CCS892001R0061	0.49	1
	36	8	411732	S802N-D8	2CCS892001R0081	0.49	1
	36	10	204884	S802N-D10	2CCS892001R0101	0.49	1
	36	13	204891	S802N-D13	2CCS892001R0131	0.49	1
	36	16	204907	S802N-D16	2CCS892001R0161	0.49	1
	36	20	204914	S802N-D20	2CCS892001R0201	0.49	1
	36	25	204921	S802N-D25	2CCS892001R0251	0.49	1
	36	32	204938	S802N-D32	2CCS892001R0321	0.49	1
	36	40	204945	S802N-D40	2CCS892001R0401	0.49	1
	36	50	204952	S802N-D50	2CCS892001R0501	0.49	1
	36	63	204969	S802N-D63	2CCS892001R0631	0.49	1
	36	80	204976	S802N-D80	2CCS892001R0801	0.49	1
	36	100	204983	S802N-D100	2CCS892001R0821	0.49	1
	36	125	204990	S802N-D125	2CCS892001R0841	0.49	1
3	36	6	408527	S803N-D6	2CCS893001R0061	0.74	1
	36	8	411749	S803N-D8	2CCS893001R0081	0.74	1
	36	10	205003	S803N-D10	2CCS893001R0101	0.74	1
	36	13	205010	S803N-D13	2CCS893001R0131	0.74	1
	36	16	205027	S803N-D16	2CCS893001R0161	0.74	1
	36	20	205034	S803N-D20	2CCS893001R0201	0.74	1
	36	25	205041	S803N-D25	2CCS893001R0251	0.74	1
	36	32	205058	S803N-D32	2CCS893001R0321	0.74	1
	36	40	205065	S803N-D40	2CCS893001R0401	0.74	1
	36	50	205072	S803N-D50	2CCS893001R0501	0.74	1
	36	63	205089	S803N-D63	2CCS893001R0631	0.74	1
	36	80	205096	S803N-D80	2CCS893001R0801	0.74	1
	36	100	205102	S803N-D100	2CCS893001R0821	0.74	1
	36	125	205119	S803N-D125	2CCS893001R0841	0.74	1

S800N-D Characteristic D

$I_{cu} = 36 \text{ kA}$; with interchangeable cage terminal

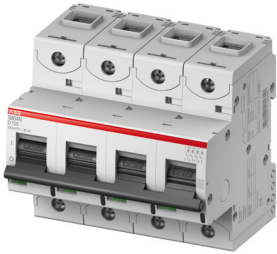

2CCS894001R0001



Number of poles	I_{cu} [kA]	Rated current [A]	GTIN EAN 7612271	Order details		Weight [kg]	Pack. unit
				Type Code	Order code		
4	36	6	408534	S804N-D6	2CCS894001R0061	0.98	1
	36	8	411756	S804N-D8	2CCS894001R0081	0.98	1
	36	10	205126	S804N-D10	2CCS894001R0101	0.98	1
	36	13	205133	S804N-D13	2CCS894001R0131	0.98	1
	36	16	205140	S804N-D16	2CCS894001R0161	0.98	1
	36	20	205157	S804N-D20	2CCS894001R0201	0.98	1
	36	25	205164	S804N-D25	2CCS894001R0251	0.98	1
	36	32	205171	S804N-D32	2CCS894001R0321	0.98	1
	36	40	205188	S804N-D40	2CCS894001R0401	0.98	1
	36	50	205195	S804N-D50	2CCS894001R0501	0.98	1
	36	63	205201	S804N-D63	2CCS894001R0631	0.98	1
	36	80	205218	S804N-D80	2CCS894001R0801	0.98	1
	36	100	205225	S804N-D100	2CCS894001R0821	0.98	1
	36	125	205232	S804N-D125	2CCS894001R0841	0.98	1

FONLEE
豐立自動控制器材有限公司
www.fonlee.com.tw

S800C-B Characteristic B

$I_{cu} = 25$ kA; with interchangeable cage terminal



2CCC413262F0001

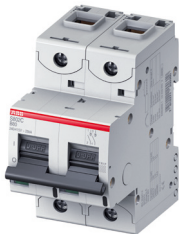

2CCC413263F0001



2CCC413264F0001

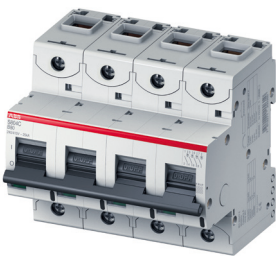

2CCC413265F0001



Number of poles	I_{cu} [kA]	Rated current [A]	GTIN EAN 76122712	Order details		Weight [kg]	Pack. unit
				Type Code	Order code		
1	25	10	12087	S801C-B10	2CCS881001R0105	0.25	1
	25	13	12247	S801C-B13	2CCS881001R0135	0.25	1
	25	16	12407	S801C-B16	2CCS881001R0165	0.25	1
	25	20	12568	S801C-B20	2CCS881001R0205	0.25	1
	25	25	12728	S801C-B25	2CCS881001R0255	0.25	1
	25	32	12889	S801C-B32	2CCS881001R0325	0.25	1
	25	40	13046	S801C-B40	2CCS881001R0405	0.25	1
	25	50	13206	S801C-B50	2CCS881001R0505	0.25	1
	25	63	13367	S801C-B63	2CCS881001R0635	0.25	1
	25	80	13527	S801C-B80	2CCS881001R0805	0.25	1
	25	100	13688	S801C-B100	2CCS881001R0825	0.25	1
	25	125	13848	S801C-B125	2CCS881001R0845	0.25	1
	2	25	10	12094	S802C-B10	2CCS882001R0105	0.49
25		13	12254	S802C-B13	2CCS882001R0135	0.49	1
25		16	12414	S802C-B16	2CCS882001R0165	0.49	1
25		20	12575	S802C-B20	2CCS882001R0205	0.49	1
25		25	12735	S802C-B25	2CCS882001R0255	0.49	1
25		32	12896	S802C-B32	2CCS882001R0325	0.49	1
25		40	13053	S802C-B40	2CCS882001R0405	0.49	1
25		50	13213	S802C-B50	2CCS882001R0505	0.49	1
25		63	13374	S802C-B63	2CCS882001R0635	0.49	1
25		80	13534	S802C-B80	2CCS882001R0805	0.49	1
25		100	13695	S802C-B100	2CCS882001R0825	0.49	1
25		125	13855	S802C-B125	2CCS882001R0845	0.49	1
3		25	10	12100	S803C-B10	2CCS883001R0105	0.74
	25	13	12261	S803C-B13	2CCS883001R0135	0.74	1
	25	16	12421	S803C-B16	2CCS883001R0165	0.74	1
	25	20	12582	S803C-B20	2CCS883001R0205	0.74	1
	25	25	12742	S803C-B25	2CCS883001R0255	0.74	1
	25	32	12902	S803C-B32	2CCS883001R0325	0.74	1
	25	40	13060	S803C-B40	2CCS883001R0405	0.74	1
	25	50	13220	S803C-B50	2CCS883001R0505	0.74	1
	25	63	13381	S803C-B63	2CCS883001R0635	0.74	1
	25	80	13541	S803C-B80	2CCS883001R0805	0.74	1
	25	100	13701	S803C-B100	2CCS883001R0825	0.74	1
	25	125	13862	S803C-B125	2CCS883001R0845	0.74	1
	4	25	10	12117	S804C-B10	2CCS884001R0105	0.98
25		13	12278	S804C-B13	2CCS884001R0135	0.98	1
25		16	12438	S804C-B16	2CCS884001R0165	0.98	1
25		20	12599	S804C-B20	2CCS884001R0205	0.98	1
25		25	12759	S804C-B25	2CCS884001R0255	0.98	1
25		32	12919	S804C-B32	2CCS884001R0325	0.98	1
25		40	13077	S804C-B40	2CCS884001R0405	0.98	1
25		50	13237	S804C-B50	2CCS884001R0505	0.98	1
25		63	13398	S804C-B63	2CCS884001R0635	0.98	1
25		80	13558	S804C-B80	2CCS884001R0805	0.98	1
25		100	13718	S804C-B100	2CCS884001R0825	0.98	1
25		125	13879	S804C-B125	2CCS884001R0845	0.98	1

S800C-C Characteristic C

$I_{cu} = 25$ kA; with interchangeable cage terminal



2CCC413266F0001

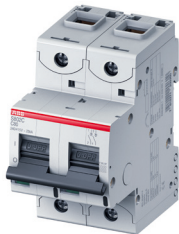

2CCC413267F0001

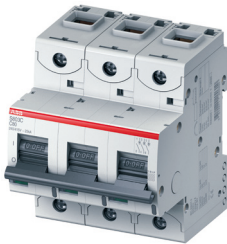

2CCC413268F0001

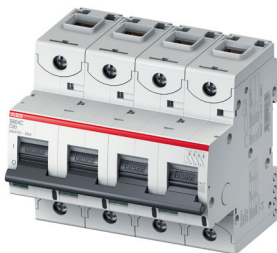

2CCC413269F0001



Number of poles	I_{cu} [kA]	Rated current [A]	GTIN EAN 76122712	Order details		Weight [kg]	Pack. unit
				Type Code	Order code		
1	25	10	12124	S801C-C10	2CCS881001R0104	0.25	1
	25	13	12285	S801C-C13	2CCS881001R0134	0.25	1
	25	16	12445	S801C-C16	2CCS881001R0164	0.25	1
	25	20	12605	S801C-C20	2CCS881001R0204	0.25	1
	25	25	12766	S801C-C25	2CCS881001R0254	0.25	1
	25	32	12926	S801C-C32	2CCS881001R0324	0.25	1
	25	40	13084	S801C-C40	2CCS881001R0404	0.25	1
	25	50	13244	S801C-C50	2CCS881001R0504	0.25	1
	25	63	13404	S801C-C63	2CCS881001R0634	0.25	1
	25	80	13565	S801C-C80	2CCS881001R0804	0.25	1
	25	100	13725	S801C-C100	2CCS881001R0824	0.25	1
	25	125	13886	S801C-C125	2CCS881001R0844	0.25	1
	2	25	10	12131	S802C-C10	2CCS882001R0104	0.49
25		13	12292	S802C-C13	2CCS882001R0134	0.49	1
25		16	12452	S802C-C16	2CCS882001R0164	0.49	1
25		20	12612	S802C-C20	2CCS882001R0204	0.49	1
25		25	12773	S802C-C25	2CCS882001R0254	0.49	1
25		32	12933	S802C-C32	2CCS882001R0324	0.49	1
25		40	13091	S802C-C40	2CCS882001R0404	0.49	1
25		50	13251	S802C-C50	2CCS882001R0504	0.49	1
25		63	13411	S802C-C63	2CCS882001R0634	0.49	1
25		80	13572	S802C-C80	2CCS882001R0804	0.49	1
25		100	13732	S802C-C100	2CCS882001R0824	0.49	1
25		125	13893	S802C-C125	2CCS882001R0844	0.49	1
3		25	10	12148	S803C-C10	2CCS883001R0104	0.74
	25	13	12308	S803C-C13	2CCS883001R0134	0.74	1
	25	16	12469	S803C-C16	2CCS883001R0164	0.74	1
	25	20	12629	S803C-C20	2CCS883001R0204	0.74	1
	25	25	12780	S803C-C25	2CCS883001R0254	0.74	1
	25	32	12940	S803C-C32	2CCS883001R0324	0.74	1
	25	40	13107	S803C-C40	2CCS883001R0404	0.74	1
	25	50	13268	S803C-C50	2CCS883001R0504	0.74	1
	25	63	13428	S803C-C63	2CCS883001R0634	0.74	1
	25	80	13589	S803C-C80	2CCS883001R0804	0.74	1
	25	100	13749	S803C-C100	2CCS883001R0824	0.74	1
	25	125	13909	S803C-C125	2CCS883001R0844	0.74	1
	4	25	10	12155	S804C-C10	2CCS884001R0104	0.98
25		13	12315	S804C-C13	2CCS884001R0134	0.98	1
25		16	12476	S804C-C16	2CCS884001R0164	0.98	1
25		20	12636	S804C-C20	2CCS884001R0204	0.98	1
25		25	12797	S804C-C25	2CCS884001R0254	0.98	1
25		32	12957	S804C-C32	2CCS884001R0324	0.98	1
25		40	13114	S804C-C40	2CCS884001R0404	0.98	1
25		50	13275	S804C-C50	2CCS884001R0504	0.98	1
25		63	13435	S804C-C63	2CCS884001R0634	0.98	1
25		80	13596	S804C-C80	2CCS884001R0804	0.98	1
25		100	13756	S804C-C100	2CCS884001R0824	0.98	1
25		125	13916	S804C-C125	2CCS884001R0844	0.98	1

S800C-D Characteristic D

$I_{cu} = 25 \text{ kA}$; with interchangeable cage terminal



2CCC413270F0001

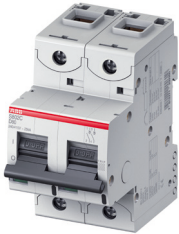

2CCC413271F0001



2CCC413272F0001

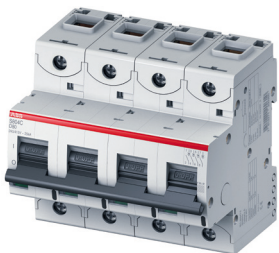

2CCC413273F0001



Number of poles	I_{cu} [kA]	Rated current [A]	GTIN EAN 76122712	Order details		Weight [kg]	Pack. unit
				Type Code	Order code		
1	25	10	12162	S801C-D10	2CCS881001R0101	0.25	1
	25	13	12322	S801C-D13	2CCS881001R0131	0.25	1
	25	16	12483	S801C-D16	2CCS881001R0161	0.25	1
	25	20	12643	S801C-D20	2CCS881001R0201	0.25	1
	25	25	12803	S801C-D25	2CCS881001R0251	0.25	1
	25	32	12964	S801C-D32	2CCS881001R0321	0.25	1
	25	40	13121	S801C-D40	2CCS881001R0401	0.25	1
	25	50	13282	S801C-D50	2CCS881001R0501	0.25	1
	25	63	13442	S801C-D63	2CCS881001R0631	0.25	1
	25	80	13602	S801C-D80	2CCS881001R0801	0.25	1
	25	100	13763	S801C-D100	2CCS881001R0821	0.25	1
	25	125	13923	S801C-D125	2CCS881001R0841	0.25	1
	2	25	10	12179	S802C-D10	2CCS882001R0101	0.49
25		13	12339	S802C-D13	2CCS882001R0131	0.49	1
25		16	12490	S802C-D16	2CCS882001R0161	0.49	1
25		20	12650	S802C-D20	2CCS882001R0201	0.49	1
25		25	12810	S802C-D25	2CCS882001R0251	0.49	1
25		32	12971	S802C-D32	2CCS882001R0321	0.49	1
25		40	13138	S802C-D40	2CCS882001R0401	0.49	1
25		50	13299	S802C-D50	2CCS882001R0501	0.49	1
25		63	13459	S802C-D63	2CCS882001R0631	0.49	1
25		80	13619	S802C-D80	2CCS882001R0801	0.49	1
25		100	13770	S802C-D100	2CCS882001R0821	0.49	1
25		125	13930	S802C-D125	2CCS882001R0841	0.49	1
3		25	10	12186	S803C-D10	2CCS883001R0101	0.74
	25	13	12346	S803C-D13	2CCS883001R0131	0.74	1
	25	16	12506	S803C-D16	2CCS883001R0161	0.74	1
	25	20	12667	S803C-D20	2CCS883001R0201	0.74	1
	25	25	12827	S803C-D25	2CCS883001R0251	0.74	1
	25	32	12988	S803C-D32	2CCS883001R0321	0.74	1
	25	40	13145	S803C-D40	2CCS883001R0401	0.74	1
	25	50	13305	S803C-D50	2CCS883001R0501	0.74	1
	25	63	13466	S803C-D63	2CCS883001R0631	0.74	1
	25	80	13626	S803C-D80	2CCS883001R0801	0.74	1
	25	100	13787	S803C-D100	2CCS883001R0821	0.74	1
	25	125	13947	S803C-D125	2CCS883001R0841	0.74	1
	4	25	10	12193	S804C-D10	2CCS884001R0101	0.98
25		13	12353	S804C-D13	2CCS884001R0131	0.98	1
25		16	12513	S804C-D16	2CCS884001R0161	0.98	1
25		20	12674	S804C-D20	2CCS884001R0201	0.98	1
25		25	12834	S804C-D25	2CCS884001R0251	0.98	1
25		32	12995	S804C-D32	2CCS884001R0321	0.98	1
25		40	13152	S804C-D40	2CCS884001R0401	0.98	1
25		50	13312	S804C-D50	2CCS884001R0501	0.98	1
25		63	13473	S804C-D63	2CCS884001R0631	0.98	1
25		80	13633	S804C-D80	2CCS884001R0801	0.98	1
25		100	13794	S804C-D100	2CCS884001R0821	0.98	1
25		125	13954	S804C-D125	2CCS884001R0841	0.98	1

S800C-K Characteristic K

$I_{cu} = 25 \text{ kA}$; with interchangeable cage terminal



2CCC413274F0001

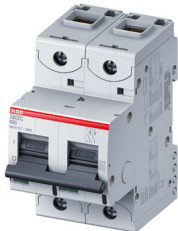

2CCC413275F0001

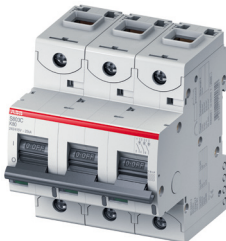

2CCC413276F0001

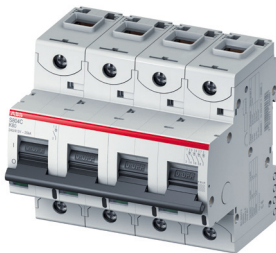

2CCC413277F0001



Number of poles	I_{cu} [kA]	Rated current [A]	GTIN EAN 76122712	Order details		Weight [kg]	Pack. unit
				Type Code	Order code		
1	25	10	12209	S801C-K10	2CCS881001R0427	0.25	1
	25	13	12360	S801C-K13	2CCS881001R0447	0.25	1
	25	16	12520	S801C-K16	2CCS881001R0467	0.25	1
	25	20	12681	S801C-K20	2CCS881001R0487	0.25	1
	25	25	12841	S801C-K25	2CCS881001R0517	0.25	1
	25	32	13008	S801C-K32	2CCS881001R0537	0.25	1
	25	40	13169	S801C-K40	2CCS881001R0557	0.25	1
	25	50	13329	S801C-K50	2CCS881001R0577	0.25	1
	25	63	13480	S801C-K63	2CCS881001R0597	0.25	1
	25	80	13640	S801C-K80	2CCS881001R0627	0.25	1
	25	100	13800	S801C-K100	2CCS881001R0637	0.25	1
	25	125	13961	S801C-K125	2CCS881001R0647	0.25	1
	2	25	10	12216	S802C-K10	2CCS882001R0427	0.49
25		13	12377	S802C-K13	2CCS882001R0447	0.49	1
25		16	12537	S802C-K16	2CCS882001R0467	0.49	1
25		20	12698	S802C-K20	2CCS882001R0487	0.49	1
25		25	12858	S802C-K25	2CCS882001R0517	0.49	1
25		32	13015	S802C-K32	2CCS882001R0537	0.49	1
25		40	13176	S802C-K40	2CCS882001R0557	0.49	1
25		50	13336	S802C-K50	2CCS882001R0577	0.49	1
25		63	13497	S802C-K63	2CCS882001R0597	0.49	1
25		80	13657	S802C-K80	2CCS882001R0627	0.49	1
25		100	13817	S802C-K100	2CCS882001R0637	0.49	1
25		125	13978	S802C-K125	2CCS882001R0647	0.49	1
3		25	10	12223	S803C-K10	2CCS883001R0427	0.74
	25	13	12384	S803C-K13	2CCS883001R0447	0.74	1
	25	16	12544	S803C-K16	2CCS883001R0467	0.74	1
	25	20	12704	S803C-K20	2CCS883001R0487	0.74	1
	25	25	12865	S803C-K25	2CCS883001R0517	0.74	1
	25	32	13022	S803C-K32	2CCS883001R0537	0.74	1
	25	40	13183	S803C-K40	2CCS883001R0557	0.74	1
	25	50	13343	S803C-K50	2CCS883001R0577	0.74	1
	25	63	13503	S803C-K63	2CCS883001R0597	0.74	1
	25	80	13664	S803C-K80	2CCS883001R0627	0.74	1
	25	100	13824	S803C-K100	2CCS883001R0637	0.74	1
	25	125	13985	S803C-K125	2CCS883001R0647	0.74	1
	4	25	10	12230	S804C-K10	2CCS884001R0427	0.98
25		13	12391	S804C-K13	2CCS884001R0447	0.98	1
25		16	12551	S804C-K16	2CCS884001R0467	0.98	1
25		20	12711	S804C-K20	2CCS884001R0487	0.98	1
25		25	12872	S804C-K25	2CCS884001R0517	0.98	1
25		32	13039	S804C-K32	2CCS884001R0537	0.98	1
25		40	13190	S804C-K40	2CCS884001R0557	0.98	1
25		50	13350	S804C-K50	2CCS884001R0577	0.98	1
25		63	13510	S804C-K63	2CCS884001R0597	0.98	1
25		80	13671	S804C-K80	2CCS884001R0627	0.98	1
25		100	13831	S804C-K100	2CCS884001R0637	0.98	1
25		125	13992	S804C-K125	2CCS884001R0647	0.98	1

S800B-B Characteristic B

$I_{cu} = 16 \text{ kA}$; with locked cage terminal



2CCC413368F0001



2CCC413369F0001

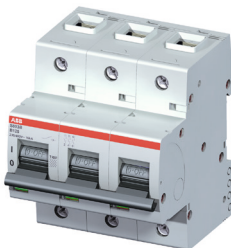

2CCC413370F0001

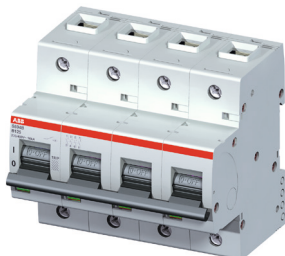

2CCC413371F0001



Number of poles	I_{cu} [kA]	Rated current [A]	GTIN EAN 76122714	Order details		Weight [kg]	Pack. unit
				Type Code	Order code		
1	16	32	15303	S801B-B32	2CCS811001R0325	0.24	1
	16	40	16539	S801B-B40	2CCS811001R0405	0.24	1
	16	50	16577	S801B-B50	2CCS811001R0505	0.24	1
	16	63	16614	S801B-B63	2CCS811001R0635	0.24	1
	16	80	16652	S801B-B80	2CCS811001R0805	0.24	1
	16	100	16690	S801B-B100	2CCS811001R0825	0.24	1
	16	125	16737	S801B-B125	2CCS811001R0845	0.24	1
2	16	32	16508	S802B-B32	2CCS812001R0325	0.49	1
	16	40	16546	S802B-B40	2CCS812001R0405	0.49	1
	16	50	16584	S802B-B50	2CCS812001R0505	0.49	1
	16	63	16621	S802B-B63	2CCS812001R0635	0.49	1
	16	80	16669	S802B-B80	2CCS812001R0805	0.49	1
	16	100	16706	S802B-B100	2CCS812001R0825	0.49	1
	16	125	16744	S802B-B125	2CCS812001R0845	0.49	1
3	16	32	16515	S803B-B32	2CCS813001R0325	0.74	1
	16	40	16553	S803B-B40	2CCS813001R0405	0.74	1
	16	50	16591	S803B-B50	2CCS813001R0505	0.74	1
	16	63	16638	S803B-B63	2CCS813001R0635	0.74	1
	16	80	16676	S803B-B80	2CCS813001R0805	0.74	1
	16	100	16713	S803B-B100	2CCS813001R0825	0.74	1
	16	125	16751	S803B-B125	2CCS813001R0845	0.74	1
4	16	32	16522	S804B-B32	2CCS814001R0325	0.98	1
	16	40	16560	S804B-B40	2CCS814001R0405	0.98	1
	16	50	16607	S804B-B50	2CCS814001R0505	0.98	1
	16	63	16645	S804B-B63	2CCS814001R0635	0.98	1
	16	80	16683	S804B-B80	2CCS814001R0805	0.98	1
	16	100	16720	S804B-B100	2CCS814001R0825	0.98	1
	16	125	16768	S804B-B125	2CCS814001R0845	0.98	1

S800B-C Characteristic C

$I_{cu} = 16 \text{ kA}$; with locked cage terminal



2CCC413368F0001



2CCC413369F0001



2CCC413370F0001

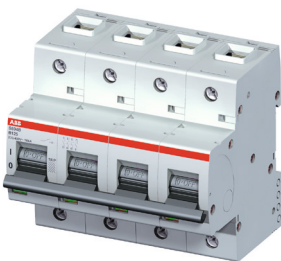

2CCC413371F0001



Number of poles	I_{cu} [kA]	Rated current [A]	GTIN EAN 76122714	Order details		Weight [kg]	Pack. unit
				Type Code	Order code		
1	16	32	16225	S801B-C32	2CCS811001R0324	0.24	1
	16	40	16263	S801B-C40	2CCS811001R0404	0.24	1
	16	50	16300	S801B-C50	2CCS811001R0504	0.24	1
	16	63	16348	S801B-C63	2CCS811001R0634	0.24	1
	16	80	16386	S801B-C80	2CCS811001R0804	0.24	1
	16	100	16423	S801B-C100	2CCS811001R0824	0.24	1
	16	125	16461	S801B-C125	2CCS811001R0844	0.24	1
2	16	32	16232	S802B-C32	2CCS812001R0324	0.49	1
	16	40	16270	S802B-C40	2CCS812001R0404	0.49	1
	16	50	16317	S802B-C50	2CCS812001R0504	0.49	1
	16	63	16355	S802B-C63	2CCS812001R0634	0.49	1
	16	80	16393	S802B-C80	2CCS812001R0804	0.49	1
	16	100	16430	S802B-C100	2CCS812001R0824	0.49	1
	16	125	16478	S802B-C125	2CCS812001R0844	0.49	1
3	16	32	16249	S803B-C32	2CCS813001R0324	0.74	1
	16	40	16287	S803B-C40	2CCS813001R0404	0.74	1
	16	50	16324	S803B-C50	2CCS813001R0504	0.74	1
	16	63	16362	S803B-C63	2CCS813001R0634	0.74	1
	16	80	16409	S803B-C80	2CCS813001R0804	0.74	1
	16	100	16447	S803B-C100	2CCS813001R0824	0.74	1
	16	125	16485	S803B-C125	2CCS813001R0844	0.74	1
4	16	32	16256	S804B-C32	2CCS814001R0324	0.98	1
	16	40	16294	S804B-C40	2CCS814001R0404	0.98	1
	16	50	16331	S804B-C50	2CCS814001R0504	0.98	1
	16	63	16379	S804B-C63	2CCS814001R0634	0.98	1
	16	80	16416	S804B-C80	2CCS814001R0804	0.98	1
	16	100	16454	S804B-C100	2CCS814001R0824	0.98	1
	16	125	16492	S804B-C125	2CCS814001R0844	0.98	1

S800B-D Characteristic D

$I_{cu} = 16 \text{ kA}$; with locked cage terminal



2CC413368F0001



2CC413369F0001

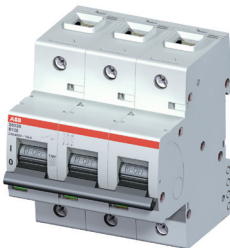

2CC413370F0001

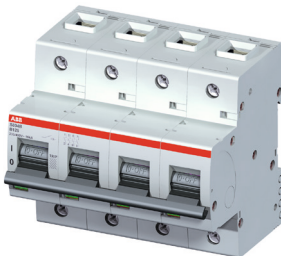

2CC413371F0001



Number of poles	I_{cu} [kA]	Rated current [A]	GTIN EAN 76122714	Order details		Weight [kg]	Pack. unit
				Type Code	Order code		
1	16	32	15945	S801B-D32	2CCS811001R0321	0.24	1
	16	40	15983	S801B-D40	2CCS811001R0401	0.24	1
	16	50	16027	S801B-D50	2CCS811001R0501	0.24	1
	16	63	16065	S801B-D63	2CCS811001R0631	0.24	1
	16	80	16102	S801B-D80	2CCS811001R0801	0.24	1
	16	100	16140	S801B-D100	2CCS811001R0821	0.24	1
	16	125	16188	S801B-D125	2CCS811001R0841	0.24	1
2	16	32	15952	S802B-D32	2CCS812001R0321	0.49	1
	16	40	15990	S802B-D40	2CCS812001R0401	0.49	1
	16	50	16034	S802B-D50	2CCS812001R0501	0.49	1
	16	63	16072	S802B-D63	2CCS812001R0631	0.49	1
	16	80	16119	S802B-D80	2CCS812001R0801	0.49	1
	16	100	16157	S802B-D100	2CCS812001R0821	0.49	1
	16	125	16195	S802B-D125	2CCS812001R0841	0.49	1
3	16	32	15969	S803B-D32	2CCS813001R0321	0.74	1
	16	40	16003	S803B-D40	2CCS813001R0401	0.74	1
	16	50	16041	S803B-D50	2CCS813001R0501	0.74	1
	16	63	16089	S803B-D63	2CCS813001R0631	0.74	1
	16	80	16126	S803B-D80	2CCS813001R0801	0.74	1
	16	100	16164	S803B-D100	2CCS813001R0821	0.74	1
	16	125	16201	S803B-D125	2CCS813001R0841	0.74	1
4	16	32	15976	S804B-D32	2CCS814001R0321	0.98	1
	16	40	16010	S804B-D40	2CCS814001R0401	0.98	1
	16	50	16058	S804B-D50	2CCS814001R0501	0.98	1
	16	63	16096	S804B-D63	2CCS814001R0631	0.98	1
	16	80	16133	S804B-D80	2CCS814001R0801	0.98	1
	16	100	16171	S804B-D100	2CCS814001R0821	0.98	1
	16	125	16218	S804B-D125	2CCS814001R0841	0.98	1

S800B-K Characteristic K

$I_{cu} = 16 \text{ kA}$; with locked cage terminal



2CCC413368F0001



2CCC413369F0001



2CCC413370F0001

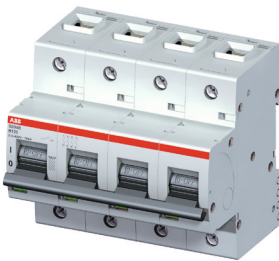

2CCC413371F0001



Number of poles	I_{cu} [kA]	Rated current [A]	GTIN EAN 76122714	Order details		Weight [kg]	Pack. unit
				Type Code	Order code		
1	16	32	15600	S801B-K32	2CCS811001R0537	0.24	1
	16	40	15723	S801B-K40	2CCS811001R0557	0.24	1
	16	50	15730	S801B-K50	2CCS811001R0577	0.24	1
	16	63	15778	S801B-K63	2CCS811001R0597	0.24	1
	16	80	15815	S801B-K80	2CCS811001R0627	0.24	1
	16	100	15860	S801B-K100	2CCS811001R0637	0.24	1
	16	125	15907	S801B-K125	2CCS811001R0647	0.24	1
2	16	32	15709	S802B-K32	2CCS812001R0537	0.49	1
	16	40	16775	S802B-K40	2CCS812001R0557	0.49	1
	16	50	15747	S802B-K50	2CCS812001R0577	0.49	1
	16	63	15785	S802B-K63	2CCS812001R0597	0.49	1
	16	80	15822	S802B-K80	2CCS812001R0627	0.49	1
	16	100	15877	S802B-K100	2CCS812001R0637	0.49	1
	16	125	15914	S802B-K125	2CCS812001R0647	0.49	1
3	16	32	15716	S803B-K32	2CCS813001R0537	0.74	1
	16	40	16799	S803B-K40	2CCS813001R0557	0.74	1
	16	50	15754	S803B-K50	2CCS813001R0577	0.74	1
	16	63	15792	S803B-K63	2CCS813001R0597	0.74	1
	16	80	15846	S803B-K80	2CCS813001R0627	0.74	1
	16	100	15884	S803B-K100	2CCS813001R0637	0.74	1
	16	125	15921	S803B-K125	2CCS813001R0647	0.74	1
4	16	32	16805	S804B-K32	2CCS814001R0537	0.98	1
	16	40	16812	S804B-K40	2CCS814001R0557	0.98	1
	16	50	15761	S804B-K50	2CCS814001R0577	0.98	1
	16	63	15808	S804B-K63	2CCS814001R0597	0.98	1
	16	80	15853	S804B-K80	2CCS814001R0627	0.98	1
	16	100	15891	S804B-K100	2CCS814001R0637	0.98	1
	16	125	15938	S804B-K125	2CCS814001R0647	0.98	1

S800HV-K Characteristic K

$I_{cu} = 4 \text{ kA}$ for voltages up to 1000 VAC



2CCC413078F0004



2CCC413079F0004

Number of poles	I_{cu} [kA]	Rated current [A]	GTIN EAN 7612271	Order details		Weight [kg]	Pack. unit
				Type Code	Order code		
1	1.5	0,5	501150	S801HV-K0,5	2CCF020049R0001	0.27	1
	1.5	1	501167	S801HV-K1	2CCF020050R0001	0.27	1
	1.5	1,6	502423	S801HV-K1,6	2CCF030021R0001	0.27	1
	1.5	2	502430	S801HV-K2	2CCF030022R0001	0.27	1
	1.5	2,5	502614	S801HV-K2,5	2CCF030030R0001	0.27	1
	1.5	3	502447	S801HV-K3	2CCF030023R0001	0.27	1
	1.5	4	502454	S801HV-K4	2CCF030024R0001	0.27	1
	1.5	5	502621	S801HV-K5	2CCF030031R0001	0.27	1
	4	6	436445	S801HV-K6	2CCF019005R0001	0.27	1
	4	8	436964	S801HV-K8	2CCF019006R0001	0.27	1
	4	10	436452	S801HV-K10	2CCF019007R0001	0.27	1
	4	13	436469	S801HV-K13	2CCF019008R0001	0.27	1
	4	16	436476	S801HV-K16	2CCF019009R0001	0.27	1
	4	20	436483	S801HV-K20	2CCF019010R0001	0.27	1
	4	25	436490	S801HV-K25	2CCF019011R0001	0.27	1
	4	32	436605	S801HV-K32	2CCF019012R0001	0.27	1
	4	40	436612	S801HV-K40	2CCF019013R0001	0.27	1
	4	50	436629	S801HV-K50	2CCF019014R0001	0.27	1
	4	63	436636	S801HV-K63	2CCF019015R0001	0.27	1
	3	80	436643	S801HV-K80	2CCF019016R0001	0.27	1
3	100	436650	S801HV-K100	2CCF019017R0001	0.27	1	
3	125	436667	S801HV-K125	2CCF019018R0001	0.27	1	
2	1.5	0,5	502461	S802HV-K0,5	2CCF030025R0001	0.54	1
	1.5	1	502478	S802HV-K1	2CCF030026R0001	0.54	1
	1.5	1,6	502638	S802HV-K1,6	2CCF030032R0001	0.54	1
	1.5	2	502485	S802HV-K2	2CCF030027R0001	0.54	1
	1.5	2,5	502492	S802HV-K2,5	2CCF030028R0001	0.54	1
	1.5	3	502645	S802HV-K3	2CCF030033R0001	0.54	1
	1.5	4	501297	S802HV-K4	2CCF020063R0001	0.54	1
	1.5	5	501303	S802HV-K5	2CCF020064R0001	0.54	1
	4	6	436674	S802HV-K6	2CCF019019R0001	0.54	1
	4	8	436681	S802HV-K8	2CCF019020R0001	0.54	1
	4	10	436698	S802HV-K10	2CCF019021R0001	0.54	1
	4	13	436704	S802HV-K13	2CCF019022R0001	0.54	1
	4	16	436711	S802HV-K16	2CCF019023R0001	0.54	1
	4	20	436728	S802HV-K20	2CCF019024R0001	0.54	1
	4	25	436742	S802HV-K25	2CCF019025R0001	0.54	1
	4	32	436759	S802HV-K32	2CCF019026R0001	0.54	1
	4	40	436766	S802HV-K40	2CCF019027R0001	0.54	1
	4	50	436773	S802HV-K50	2CCF019028R0001	0.54	1
	4	63	436780	S802HV-K63	2CCF019029R0001	0.54	1
	3	80	436797	S802HV-K80	2CCF019030R0001	0.54	1
3	100	436803	S802HV-K100	2CCF019031R0001	0.54	1	
3	125	436810	S802HV-K125	2CCF019032R0001	0.54	1	

S800HV-K Characteristic K / S800HV-C Characteristic C

$I_{cu} = 4 \text{ kA}$ for voltages up to 1000 V AC

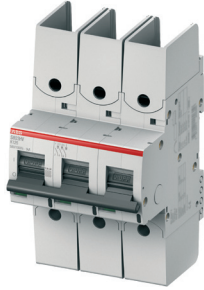

2CCCF019038R0001

Number of poles	I_{cu} [kA]	Rated current [A]	GTIN EAN 76122714	Order details		Weight [kg]	Pack. unit
				Type Code	Order code		
3	1.5	0,5	501310	S803HV-K0,5	2CCCF020065R0001	0.81	1
	1.5	1	501327	S803HV-K1	2CCCF020066R0001	0.81	1
	1.5	1,6	501334	S803HV-K1,6	2CCCF020067R0001	0.81	1
	1.5	2	501341	S803HV-K2	2CCCF020068R0001	0.81	1
	1.5	2,5	501358	S803HV-K2,5	2CCCF020069R0001	0.81	1
	1.5	3	501365	S803HV-K3	2CCCF020070R0001	0.81	1
	1.5	4	501372	S803HV-K4	2CCCF020071R0001	0.81	1
	1.5	5	501389	S803HV-K5	2CCCF020072R0001	0.81	1
	4	6	36827	S803HV-K6	2CCCF019033R0001	0.81	1
	4	8	36834	S803HV-K8	2CCCF019034R0001	0.81	1
	4	10	36841	S803HV-K10	2CCCF019035R0001	0.81	1
	4	13	36858	S803HV-K13	2CCCF019036R0001	0.81	1
	4	16	36865	S803HV-K16	2CCCF019037R0001	0.81	1
	4	20	36872	S803HV-K20	2CCCF019038R0001	0.81	1
	4	25	36889	S803HV-K25	2CCCF019039R0001	0.81	1
	4	32	36896	S803HV-K32	2CCCF019040R0001	0.81	1
	4	40	36902	S803HV-K40	2CCCF019041R0001	0.81	1
	4	50	36919	S803HV-K50	2CCCF019042R0001	0.81	1
	4	63	36926	S803HV-K63	2CCCF019043R0001	0.81	1
3	80	36933	S803HV-K80	2CCCF019044R0001	0.81	1	
3	100	36940	S803HV-K100	2CCCF019045R0001	0.81	1	
3	125	36957	S803HV-K125	2CCCF019046R0001	0.81	1	
4	10	72221	S803HV-C10	2CCCF019650R0001	0.81	1	
4	32	72245	S803HV-C32	2CCCF019651R0001	0.81	1	

S800U-K Characteristic K (UL489 certified)

$I_{cu} = 30 \text{ kA}$; with interchangeable cage terminal



2CCS881017R0427

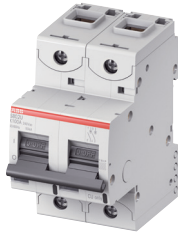

2CCS862017R0427

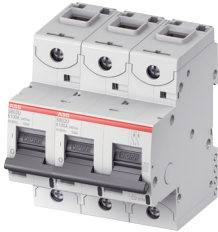

2CCS863017R0427

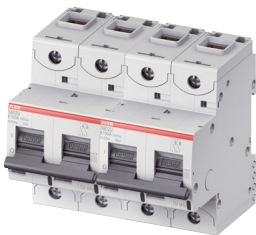

2CCS864017R0427



Number of poles	I_{cu} [kA]	Rated current [A]	GTIN EAN 76122712	Order details		Weight [kg]	Pack. unit
				Type Code	Order code		
1	30	10	14005	S801U-K10	2CCS881017R0427	0.25	1
	30	15	14043	S801U-K15	2CCS881017R0457	0.25	1
	30	20	14081	S801U-K20	2CCS881017R0487	0.25	1
	30	25	14128	S801U-K25	2CCS881017R0517	0.25	1
	30	30	14166	S801U-K30	2CCS881017R0527	0.25	1
	30	40	14203	S801U-K40	2CCS881017R0557	0.25	1
	30	50	14241	S801U-K50	2CCS881017R0577	0.25	1
	30	60	14289	S801U-K60	2CCS881017R0587	0.25	1
	30	70	14326	S801U-K70	2CCS881017R0707	0.25	1
	30	80	14364	S801U-K80	2CCS881017R0627	0.25	1
	30	90	14401	S801U-K90	2CCS881017R0907	0.25	1
	30	100	14449	S801U-K100	2CCS881017R0637	0.25	1
	2	50	10	14012	S802U-K10	2CCS862017R0427	0.49
50		15	14050	S802U-K15	2CCS862017R0457	0.49	1
50		20	14098	S802U-K20	2CCS862017R0487	0.49	1
50		25	14135	S802U-K25	2CCS862017R0517	0.49	1
50		30	14173	S802U-K30	2CCS862017R0527	0.49	1
50		40	14210	S802U-K40	2CCS862017R0557	0.49	1
50		50	14258	S802U-K50	2CCS862017R0577	0.49	1
50		60	14296	S802U-K60	2CCS862017R0587	0.49	1
50		70	14333	S802U-K70	2CCS862017R0707	0.49	1
50		80	14371	S802U-K80	2CCS862017R0627	0.49	1
50		90	14418	S802U-K90	2CCS862017R0907	0.49	1
50		100	14456	S802U-K100	2CCS862017R0637	0.49	1
3		50	10	14029	S803U-K10	2CCS863017R0427	0.74
	50	15	14067	S803U-K15	2CCS863017R0457	0.74	1
	50	20	14104	S803U-K20	2CCS863017R0487	0.74	1
	50	25	14142	S803U-K25	2CCS863017R0517	0.74	1
	50	30	14180	S803U-K30	2CCS863017R0527	0.74	1
	50	40	14227	S803U-K40	2CCS863017R0557	0.74	1
	50	50	14265	S803U-K50	2CCS863017R0577	0.74	1
	50	60	14302	S803U-K60	2CCS863017R0587	0.74	1
	50	70	14340	S803U-K70	2CCS863017R0707	0.74	1
	50	80	14388	S803U-K80	2CCS863017R0627	0.74	1
	50	90	14425	S803U-K90	2CCS863017R0907	0.74	1
	50	100	14463	S803U-K100	2CCS863017R0637	0.74	1
	4	50	10	14036	S804U-K10	2CCS864017R0427	0.98
50		15	14074	S804U-K15	2CCS864017R0457	0.98	1
50		20	14111	S804U-K20	2CCS864017R0487	0.98	1
50		25	14159	S804U-K25	2CCS864017R0517	0.98	1
50		30	14197	S804U-K30	2CCS864017R0527	0.98	1
50		40	14234	S804U-K40	2CCS864017R0557	0.98	1
50		50	14272	S804U-K50	2CCS864017R0577	0.98	1
50		60	14319	S804U-K60	2CCS864017R0587	0.98	1
50		70	14357	S804U-K70	2CCS864017R0707	0.98	1
50		80	14395	S804U-K80	2CCS864017R0627	0.98	1
50		90	14432	S804U-K90	2CCS864017R0907	0.98	1
50		100	14470	S804U-K100	2CCS864017R0637	0.98	1

S800U-Z Characteristic Z (UL489 certified)

$I_{cu} = 50 \text{ kA}$; with interchangeable cage terminal



2CCC413315F0001



2CCC413316F0001

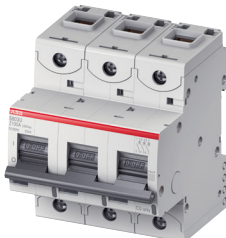

2CCC413317F0001

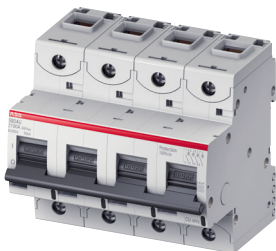

2CCC413318F0001



Number of poles	I_{cu} [kA]	Rated current [A]	GTIN EAN 76122712	Order details		Weight [kg]	Pack. unit
				Type Code	Order code		
1	30	10	14487	S801U-Z10	2CCS881017R0105	0.25	1
	30	15	14524	S801U-Z15	2CCS881017R0155	0.25	1
	30	20	14562	S801U-Z20	2CCS881017R0205	0.25	1
	30	25	14609	S801U-Z25	2CCS881017R0255	0.25	1
	30	30	14647	S801U-Z30	2CCS881017R0305	0.25	1
	30	40	14685	S801U-Z40	2CCS881017R0405	0.25	1
	30	50	14722	S801U-Z50	2CCS881017R0505	0.25	1
	30	60	14760	S801U-Z60	2CCS881017R0605	0.25	1
	30	70	14807	S801U-Z70	2CCS881017R0705	0.25	1
	30	80	14845	S801U-Z80	2CCS881017R0805	0.25	1
	30	90	14883	S801U-Z90	2CCS881017R0905	0.25	1
	30	100	14920	S801U-Z100	2CCS881017R0825	0.25	1
	2	50	10	14494	S802U-Z10	2CCS862017R0105	0.49
50		15	14531	S802U-Z15	2CCS862017R0155	0.49	1
50		20	14579	S802U-Z20	2CCS862017R0205	0.49	1
50		25	14616	S802U-Z25	2CCS862017R0255	0.49	1
50		30	14654	S802U-Z30	2CCS862017R0305	0.49	1
50		40	14692	S802U-Z40	2CCS862017R0405	0.49	1
50		50	14739	S802U-Z50	2CCS862017R0505	0.49	1
50		60	14777	S802U-Z60	2CCS862017R0605	0.49	1
50		70	14814	S802U-Z70	2CCS862017R0705	0.49	1
50		80	14852	S802U-Z80	2CCS862017R0805	0.49	1
50		90	14890	S802U-Z90	2CCS862017R0905	0.49	1
50		100	14937	S802U-Z100	2CCS862017R0825	0.49	1
3		50	10	14500	S803U-Z10	2CCS863017R0105	0.74
	50	15	14548	S803U-Z15	2CCS863017R0155	0.74	1
	50	20	14586	S803U-Z20	2CCS863017R0205	0.74	1
	50	25	14623	S803U-Z25	2CCS863017R0255	0.74	1
	50	30	14661	S803U-Z30	2CCS863017R0305	0.74	1
	50	40	14708	S803U-Z40	2CCS863017R0405	0.74	1
	50	50	14746	S803U-Z50	2CCS863017R0505	0.74	1
	50	60	14784	S803U-Z60	2CCS863017R0605	0.74	1
	50	70	14821	S803U-Z70	2CCS863017R0705	0.74	1
	50	80	14869	S803U-Z80	2CCS863017R0805	0.74	1
	50	90	14906	S803U-Z90	2CCS863017R0905	0.74	1
	50	100	14944	S803U-Z100	2CCS863017R0825	0.74	1
	4	50	10	14517	S804U-Z10	2CCS864017R0105	0.98
50		15	14555	S804U-Z15	2CCS864017R0155	0.98	1
50		20	14593	S804U-Z20	2CCS864017R0205	0.98	1
50		25	14630	S804U-Z25	2CCS864017R0255	0.98	1
50		30	14678	S804U-Z30	2CCS864017R0305	0.98	1
50		40	14715	S804U-Z40	2CCS864017R0405	0.98	1
50		50	14753	S804U-Z50	2CCS864017R0505	0.98	1
50		60	14791	S804U-Z60	2CCS864017R0605	0.98	1
50		70	14838	S804U-Z70	2CCS864017R0705	0.98	1
50		80	14876	S804U-Z80	2CCS864017R0805	0.98	1
50		90	14913	S804U-Z90	2CCS864017R0905	0.98	1
50		100	14951	S804U-Z100	2CCS864017R0825	0.98	1

S804U-UCZ (UL489 certified)

$I_{cu} = 10 \text{ kA}$ for voltages up to 600 V DC

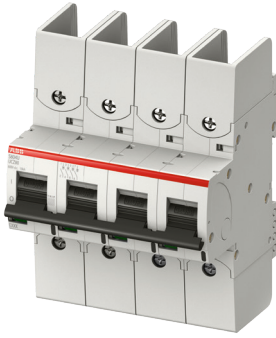

2CCS413373F0001

Number of poles	I_{cu} [kA]	Rated current [A]	GTIN EAN 7612271	Order details		Weight [kg]	Pack. unit
				Type Code	Order code		
4	10	10	420703	S804U-UCZ10	2CCS248356R0001	0.98	1
	10	15	420710	S804U-UCZ15	2CCS248357R0001	0.98	1
	10	20	420727	S804U-UCZ20	2CCS248358R0001	0.98	1
	10	25	420734	S804U-UCZ25	2CCS248359R0001	0.98	1
	10	30	420741	S804U-UCZ30	2CCS248360R0001	0.98	1
	10	40	420758	S804U-UCZ40	2CCS248361R0001	0.98	1
	10	50	420765	S804U-UCZ50	2CCS248362R0001	0.98	1
	10	60	420772	S804U-UCZ60	2CCS248363R0001	0.98	1
	10	70	420789	S804U-UCZ70	2CCS248364R0001	0.98	1
	10	80	420796	S804U-UCZ80	2CCS248365R0001	0.98	1

FONLEE
 豐立自動控制器材有限公司
 www.FONLEE.COM.TW

S800PV-SP Characteristic PV-SP (used in photovoltaic systems)

Photovoltaic string protection with interchangeable cage terminal

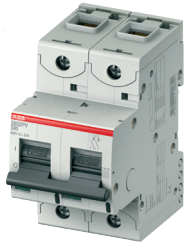

2CCCF019596R0001

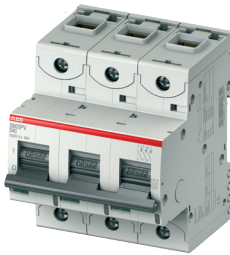

2CCCF019609R0001

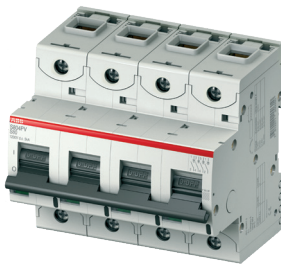

2CCCF019586R0001



Number of poles	I _{cu} [kA]	Rated current [A]	GTIN EAN 76122712	Order details		Weight [kg]	Pack. unit
				Type Code	Order code		
2	5	5	71170	S802PV-SP5	2CCCF019596R0001	0.49	1
	5	6	72115	S802PV-SP6	2CCCF019643R0001	0.49	1
	5	8	72139	S802PV-SP8	2CCCF019644R0001	0.49	1
	5	10	71194	S802PV-SP10	2CCCF019597R0001	0.49	1
	5	13	71217	S802PV-SP13	2CCCF019598R0001	0.49	1
	5	16	71231	S802PV-SP16	2CCCF019599R0001	0.49	1
	5	20	71255	S802PV-SP20	2CCCF019600R0001	0.49	1
	5	25	71279	S802PV-SP25	2CCCF019601R0001	0.49	1
	5	32	71293	S802PV-SP32	2CCCF019602R0001	0.49	1
	5	40	71316	S802PV-SP40	2CCCF019603R0001	0.49	1
	5	50	71330	S802PV-SP50	2CCCF019604R0001	0.49	1
	5	63	71354	S802PV-SP63	2CCCF019605R0001	0.49	1
	5	80	71378	S802PV-SP80	2CCCF019606R0001	0.49	1
	5	100	71392	S802PV-SP100	2CCCF019607R0001	0.49	1
	5	125	71415	S802PV-SP125	2CCCF019608R0001	0.49	1
	3	5	5	71439	S803PV-SP5	2CCCF019609R0001	0.74
5		6	72153	S803PV-SP6	2CCCF019645R0001	0.74	1
5		8	72177	S803PV-SP8	2CCCF019646R0001	0.74	1
5		10	71453	S803PV-SP10	2CCCF019610R0001	0.74	1
5		13	71477	S803PV-SP13	2CCCF019611R0001	0.74	1
5		16	71491	S803PV-SP16	2CCCF019612R0001	0.74	1
5		20	71514	S803PV-SP20	2CCCF019613R0001	0.74	1
5		25	71538	S803PV-SP25	2CCCF019614R0001	0.74	1
5		32	71552	S803PV-SP32	2CCCF019615R0001	0.74	1
5		40	71576	S803PV-SP40	2CCCF019616R0001	0.74	1
5		50	71590	S803PV-SP50	2CCCF019617R0001	0.74	1
5		63	71613	S803PV-SP63	2CCCF019618R0001	0.74	1
5		80	71637	S803PV-SP80	2CCCF019619R0001	0.74	1
5		100	71651	S803PV-SP100	2CCCF019620R0001	0.74	1
5		125	71675	S803PV-SP125	2CCCF019621R0001	0.74	1
4		5	5	52124	S804PV-SP5	2CCCF019586R0001	0.98
	5	6	72191	S804PV-SP6	2CCCF019647R0001	0.98	1
	5	8	72214	S804PV-SP8	2CCCF019648R0001	0.98	1
	5	10	71699	S804PV-SP10	2CCCF019622R0001	0.98	1
	5	13	71712	S804PV-SP13	2CCCF019623R0001	0.98	1
	5	16	71736	S804PV-SP16	2CCCF019624R0001	0.98	1
	5	20	71750	S804PV-SP20	2CCCF019625R0001	0.98	1
	5	25	71774	S804PV-SP25	2CCCF019626R0001	0.98	1
	5	32	71798	S804PV-SP32	2CCCF019627R0001	0.98	1
	5	40	71811	S804PV-SP40	2CCCF019628R0001	0.98	1
	5	50	71835	S804PV-SP50	2CCCF019629R0001	0.98	1
	5	63	71859	S804PV-SP63	2CCCF019630R0001	0.98	1
	5	80	71873	S804PV-SP80	2CCCF019631R0001	0.98	1
	5	100	71897	S804PV-SP100	2CCCF019632R0001	0.98	1
	5	125	71910	S804PV-SP125	2CCCF019633R0001	0.98	1

S800PV-SD (used in photovoltaic systems)

Photovoltaic disconnecter with interchangeable cage terminal



2CCCF0132249F0001

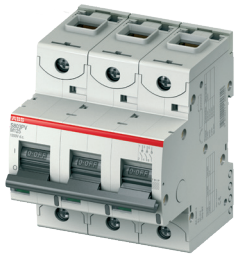

2CCCF0132250F0001

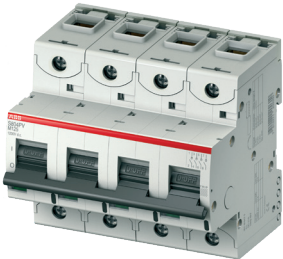

2CCCF0132251F0001



Number of poles	I_{cu} [kA]	Rated current [A]	GTIN EAN 76122712	Order details		Weight [kg]	Pack. unit
				Type Code	Order code		
2	1.5	32	71958	S802PV-SD32	2CCCF019635R0001	0.43	1
	1.5	63	71934	S802PV-SD63	2CCCF019634R0001	0.43	1
	1.5	125	71972	S802PV-SD125	2CCCF019636R0001	0.43	1
3	1.5	32	71996	S803PV-SD32	2CCCF019637R0001	0.65	1
	1.5	63	72016	S803PV-SD63	2CCCF019638R0001	0.65	1
	1.5	125	72030	S803PV-SD125	2CCCF019639R0001	0.65	1
4	1.5	32	72054	S804PV-SD32	2CCCF019640R0001	0.86	1
	1.5	63	72078	S804PV-SD63	2CCCF019641R0001	0.86	1
	1.5	125	72092	S804PV-SD125	2CCCF019642R0001	0.86	1

S802PV-M-H (used in photovoltaic systems)

Photovoltaic 2-pole disconnector (polarized)



2CCC413379F0001

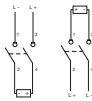

Number of poles	I_{cu} [kA]	Rated current [A]	GTIN EAN 7612271	Order details		Weight [kg]	Pack. unit
				Type Code	Order code		
2	1.5	32	419035	S802PV-M32-H	2CCP247204R0001	0.43	1
	1.5	63	419042	S802PV-M63-H	2CCP247205R0001	0.43	1
	1.5	100	419301	S802PV-M100-H	2CCP247212R0001	0.43	1

FONLEE
 豐立自動控制器材有限公司
 www.FONLEE.COM.TW

S804U-PVS (UL489B certified, used in photovoltaic systems)

Ground fault detector interrupter (GFDI)

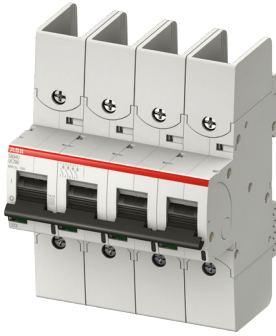

2CC041373F0001

Number of poles	I_{cu} [kA]	Rated current [A]	GTIN EAN 7612271	Order details		Weight [kg]	Pack. unit
				Type Code	Order code		
4	3	5	419929	S804U-PVS5	2CCP824017R1159	0.98	1

FONLEE
 豐立自動控制器材有限公司
 WWW.FONLEE.COM.TW

S800

Accessories



2CCC413069F0001



Article	Order details		GTIN EAN 761227	Weight [kg]	Pack. unit
	Type Code	Order code			
Auxiliary contact	S800-AUX	2CCS800900R0011	1206802	0.05	1
Auxiliary/signal contact	S800-AUX/ALT	2CCS800900R0021	1206819	0.05	1
Disconnectable neutral conductor 63 A	S800-NT	2CCS800900R0061	1208196	0.12	1
Remote Switching Unit* S800-RSU-H	S800-RSU-H	2CCS800900R0501	1411244	0.3	1
Remote Switching Unit* S800W-RSU	S800W-RSU	2CCS800900R0511	1411169	0.3	1
S800-RSU cable incl. plug 3 meters cable 0,5 mm² (AWG20) incl. 10-pole Micro Fit 3.0 plug	S800-RSU-CP	2CCS800900R0541	1412869	0.35	1
10-pole Micro Fit 3.0 plug	S800-RSU-P	2CCS800900R0551	1412845	0.00	1



2CCC413070F0001



2CCC413067F0001



2CCC413353F0001



2CCC413357F0001

* High performance circuit breaker is not included in delivery

S800

Accessories

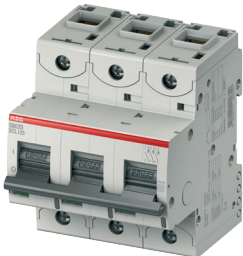

2CCC413019F0002

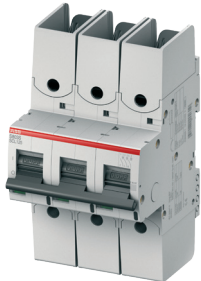

2CCC413020F0001



2CCC412028F0001

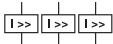

2CCC413364F0001

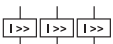

Article	Order details			Weight [kg]	Pack. unit
	Type Code	Order code	GTIN EAN		
Short-circuit current limiter with interchangeable cage terminal [A]				7612271	
32	S803S-SCL32	2CCS800900R0291	1208912	0.74	1
63	S803S-SCL63	2CCS800900R0301	1208929	0.74	1
125	S803S-SCL125	2CCS800900R0281	1208905	0.74	1
Short-circuit current limiter with interchangeable ring terminal connection [A]				761227	
32	S803S-SCL32-R	2CCS800900R0332	1408916	0.74	1
63	S803S-SCL63-R	2CCS800900R0331	1208950	0.74	1
125	S803S-SCL125-R	2CCS800900R0311	1208936	0.74	1
Self-resetting short-circuit limiter IEC version [A]				7612271	
32	S801S-SCL32-SR	2CCS801901R0539	412012	0.25	1
63	S801S-SCL63-SR	2CCS801901R0599	412036	0.25	1
100	S801S-SCL100-SR	2CCS801901R0639	411992	0.25	1
32	S802S-SCL32-SR	2CCS802901R0539	412074	0.5	1
63	S802S-SCL63-SR	2CCS802901R0599	412098	0.5	1
100	S802S-SCL100-SR	2CCS802901R0639	412050	0.5	1
32	S803S-SCL32-SR	2CCS803901R0539	411930	0.75	1
63	S803S-SCL63-SR	2CCS803901R0599	411947	0.75	1
100	S803S-SCL100-SR	2CCS803901R0639	411954	0.75	1
Self-resetting short-circuit limiter World version (IEC/UL) [A]				7612271	
32	S803W-SCL32-SR	2CCS803917R0539	412319	0.75	1
63	S803W-SCL63-SR	2CCS803917R0599	412326	0.75	1
100	S803W-SCL100-SR	2CCS803917R0639	412302	0.75	1

S800

Accessories

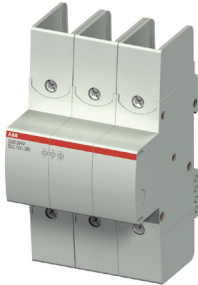

2CCC41349P0001



2CCC41329P0001



2CCC41323P0001



2CCC41306P0002



2CCC41306P0001

Article	Order details		GTIN EAN	Weight [kg]	Pack. unit
	Type Code	Order code			
Self-resetting short-circuit limiter [A]			76122714		
32	S803HV-SCL32-SR	2CCF019047R0001	37008	0.75	1
63	S803HV-SCL63-SR	2CCF019048R0001	37107	0.75	1
100	S803HV-SCL100-SR	2CCF019049R0001	37114	0.75	1
Shunt operation release			761227		
12VAC/DC	S800-SOR12	2CCS800900R0201	1212070	0,15	1
24VAC/DC	S800-SOR24	2CCS800900R0191	1208318	0.15	1
48...130VAC/DC	S800-SOR130	2CCS800900R0221	1208349	0.15	1
110...250VAC/DC	S800-SOR250	2CCS800900R0211	1208332	0.15	1
220...400VAC/DC	S800-SOR400	2CCS800900R0231	1208356	0.15	1
Undervoltage release			761227		
24...36VAC/DC	S800-UVR36	2CCS800900R0241	1208363	0.15	1
48...60VAC/DC	S800-UVR60	2CCS800900R0251	1208370	0.15	1
110...130VAC/DC	S800-UVR130	2CCS800900R0261	1208387	0.15	1
220...250VAC/DC	S800-UVR250	2CCS800900R0271	1208394	0.15	1
Rotary drive adapter for 2- to 4-pole high performance MCB			80156446		
Rotary drive	S800-RD	2CCS800900R0041	25764	0.08	1
Anthracite/Standard rotary handle for door assembly			80156446		
Anthracite rotary handle	S800-RHE-H	1SDA060150R0001	25571	0.02	1

S800

Accessories

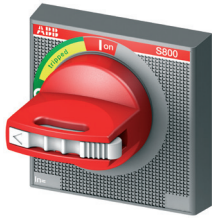

2CCC413069F0001



2CCC413064F0001

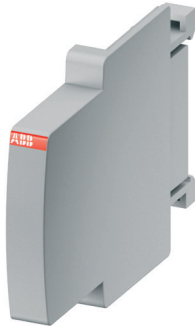

2CCC413068F0001



2CCC413066F0001



2CCC413068F0001

Article	Order details		Weight [kg]	Pack. unit	
	Type Code	Order code			
Red/Emergency rotary handle for door assembly			GTIN EAN 80156446		
Red rotary handle	S800-RHE-EM	1SDA060151R0001	25771	0.02	1
Axle extension Rotary drive-rotary handle 6x6 mm			GTIN EAN 80156446		
Axial extension 500 mm	S800-RHE-S	1SDA060179R0001	26242	0.2	1
IP54 kit for door mounting			GTIN EAN 80156446		
IP54 Kit	S800-RHE-IP54	1SDA060180R0001	26259	0.08	1
Intermediate piece 9 mm			GTIN EAN 76122712		
Intermediate piece 9 mm	S800-IP9	2CCS800900R0031	08202	0.01	1
Padlock lever lock with hasp			GTIN EAN 76122712		
Padlock lever lock with hasp 4 mm	S800-PLL	2CCS800900R0051	08189	0.12	10
UL locking device*			GTIN EAN 76122712		
UL locking device	S800U-PLL	2CCS800017R0001	15057	0.02	1

*High performance circuit breaker and lockout tag are not included in delivery

S800

Accessories



2CCC413049F0001



2CCC413046F0004



2CCC413057F0001



2CCC413089F0001



2CCC413059F0001



2CCC413377F0001

Article	Order details		GTIN EAN	Weight [kg]	Pack. unit
	Type Code	Order code			
Interchangeable adapter kit			76122712		
Cage terminal	S800-CT2125	2CCS800900R0181	12049	0.03	2
Cage terminal	S800-CT4125	2CCS800900R0151	12032	0.06	4
Ring terminal connection	S800-RT2125	2CCS800900R0161	08240	0.03	2
Ring terminal connection	S800-RT4125	2CCS800900R0131	08219	0.06	4
Busbar			GTIN EAN 76122712		
Busbar 250 A with 24 contacts pins, 3P	S803-BB250	2CCS800900R0071	08288	1.5	1
Busbar			GTIN EAN 76122714		
Busbar 250 A with 24 contacts pins, 3P+N	S804-BB250	2CCF019568R0001	41807	2	1
Busbar 250 A with 6 contacts pins, 3P	S803-BB6	2CCF019562R0001	41302	0.375	1
Feed block			GTIN EAN 76122712		
Feed block 4p 120 mm ²	S804-BBPC120	2CCF019569R0001	41814	0.58	1
Feed block 3P 120 mm ²	S803-BBPC120	2CCS800900R0101	08301	0.46	1
Contact-protection cover			GTIN EAN 76122712		
Contact-protection cover	S800-BBIC	2CCS800900R0081	08967	0.02	12
End cap			GTIN EAN 76122712		
End cap	S800-END	2CCS800900R0091	08295	0.04	10
Pole connector			7612271		
Pole connector 50 A	S802-LINK50	2CCS800900R0411	211295	0.03	10
Pole connector 125 A	S802-LINK125	2CCS800900R0562	419103	0.15	2

S800

Accessories



2CCC451729F0001

Article	Order details		GTIN EAN	Weight [kg]	Pack. unit
	Type Code	Order code			
Smisline adapter for S800 (up to 50 A)			761227		
L1 or L2 or L3 wire bottom	ZLS973	2CCA180556R0001	144 4716	0,024	10
L1 or L2 or L3 wire bottom	ZLS973	2CCA180556R0001	144 4716	0,024	10
N wire top	ZLS972N	2CCA180557R0001	144 4723	0,024	10
N wire bottom	ZLS973N	2CCA180558R0001	144 4730	0,024	10
Dummy housing					
9mm dummy housing	ZLS965	2CCA180545R1001	1501440		5
18mm dummy housing		2CCA180550R0001	1444556	0,011	10
Connection piece (2 connectors are needed to connect)	E210-SPV	2CCC703715R0001	141 4801	0,050	30
S800-ILS					
Identification labeling system 168 x 6 x 11.5 mm	S800-ILS	2CCS800900R0121	08271	0.01	1



2CCA880225R0001



2CCA880216R0001



2CCA880210R0001



2CCA880240R0001



2CCA880220R0001

Article	Order details		GTIN EAN	Weight [kg]	Pack. unit
	Type Code	Order code			
Open-core sensors 18 mm for retrofit of MCBs (S200, SMISLINE) and RCBs (SMISLINE)			7612271		
80A	CMS-120LA	2CCA880225R0001	498627	0.012	1
40A	CMS-121LA	2CCA880226R0001	498610	0.012	1
20A	CMS-122LA	2CCA880227R0001	498603	0.012	1
Open-core sensors 18 mm for retrofit of E90 fuseholders 1000VDC					
40A	CMS-121FH	2CCA880216R0001	498597	0.012	1
20A	CMS-122FH	2CCA880217R0001	498580	0.012	1
Open-core sensors 18 mm for pro M and SMISLINE devices with twin terminals					
80A	CMS-120PS	2CCA880210R0001	452957	0.012	1
40A	CMS-121PS	2CCA880211R0001	452971	0.012	1
20A	CMS-122PS	2CCA880212R0001	452995	0.012	1
Open-core sensors 18 mm for DIN-rail mounting (universal use)					
80A	CMS-120DR	2CCA880240R0001	453077	0.015	1
40A	CMS-121DR	2CCA880241R0001	453091	0.015	1
20A	CMS-122DR	2CCA880242R0001	453114	0.015	1
Open-core sensors 18 mm for cable tie mounting (universal use)					
80A	CMS-120CA	2CCA880220R0001	453015	0.011	1
40A	CMS-121CA	2CCA880221R0001	453039	0.011	1
20A	CMS-122CA	2CCA880222R0001	453053	0.011	1

S800

Accessories



2CCA880124R0001



2CCA880100R0001



2CCA8801034F0001



2CCA880107R0001



2CCA880136R0001



2CCA880132R0001



2CCA880117R0001



2CCA88070F0001



2CCA88070R0001

Article	Order details Type Code	Order code	GTIN EAN 7612271	Weight [kg]	Pack. unit
Solid-core sensors 18 mm for S800 devices with cage terminals (except S800B, HV, U-UCZ, U-PVS)					
80A	CMS-100S8	2CCA880124R0001	426552	0.014	1
40A	CMS-101S8	2CCA880125R0001	426569	0.014	1
20A	CMS-102S8	2CCA880126R0001	426576	0.014	1
Solid-core sensors 18 mm for pro M & SMISLINE installation devices with twin terminals					
80A	CMS-100PS	2CCA880100R0001	419202	0.012	1
40A	CMS-101PS	2CCA880101R0001	419219	0.012	1
20A	CMS-102PS	2CCA880102R0001	419226	0.012	1
Solid-core sensors 18 mm for DIN rail mounting (universally usable)					
80A	CMS-100DR	2CCA880128R0001	426583	0.015	1
40A	CMS-101DR	2CCA880129R0001	426590	0.015	1
20A	CMS-102DR	2CCA880130R0001	426606	0.015	1
Solid-core sensors 18 mm for cable tie mounting (universally usable)					
80A	CMS-100CA	2CCA880107R0001	426613	0.011	1
40A	CMS-101CA	2CCA880108R0001	426620	0.011	1
20A	CMS-102CA	2CCA880109R0001	426637	0.011	1
Solid-core sensors 25 mm for S800 devices with cage terminals (except S800B, HV, U-UCZ, U-PVS)					
160A	CMS-200S8	2CCA880136R0001	426644	0.028	1
80A	CMS-201S8	2CCA880137R0001	426651	0.028	1
40A	CMS-202S8	2CCA880138R0001	426668	0.028	1
Solid-core sensors 25 mm for DIN-rail mounting (universal use)					
160A	CMS-200DR	2CCA880132R0001	426675	0.030	1
80A	CMS-201DR	2CCA880133R0001	426682	0.030	1
40A	CMS-202DR	2CCA880134R0001	426699	0.030	1
Solid-core sensors 25 mm for cable tie mounting (universal use)					
160A	CMS-200CA	2CCA880117R0001	426705	0.026	1
80A	CMS-201CA	2CCA880118R0001	426712	0.026	1
40A	CMS-202CA	2CCA880119R0001	426729	0.026	1
Control Unit (24VDC)					
CMS-600 Control Unit	CMS-600	2CCA880000R0001	418700	0.153	1
CMS-700 Control Unit	CMS-700	2CCA880700R0001	453138	0.329	1
Accessories					
2 m flat cable	CMS-800	2CCA880148R0001	419233	0.017	1
5 m flat cable	CMS-802	2CCA880331R0001	474225	0.045	1
10 m Flat cable	CMS-803	2CCA880332R0001	475758	0.090	1
30 m Flat cable	CMS-805	2CCA880333R0001	468880	0.270	35
Connector set (35 pcs)	CMS-820	2CCA880145R0001	419240	0.024	1

S800

Accessories

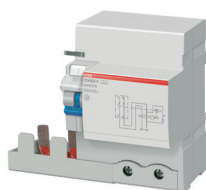

2CCC413051P0001

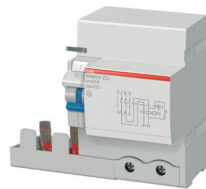

2CCC413051P0001

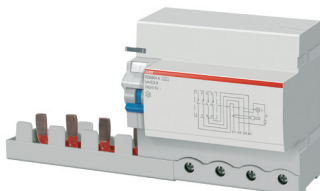

2CCC413033P0001

Assignment of the RCD-block

Type A	Type AC	Type AS	Type A-AP-R
Pulse current sensitive RCD-block	Alternating current sensitive RCD-block	Pulse current sensitive RCD-block (Selective)	Pulse current sensitive RCD-block (short-time delay)

Quantity	Rated current [A]	Order details Type Code	Type	$I_{\Delta n}$	Order code	GTIN EAN 801254	Weight [kg]	Pack. unit
2	63	DDA802AC-63/0.03	AC	0.03	2CSB802001R1630	2919704	0.3	1
2	63	DDA802AC-63/0.3	AC	0.3	2CSB802001R3630	2919902	0.3	1
2	63	DDA802A-63/0.03	A	0.03	2CSB802101R1630	2920007	0.3	1
2	63	DDA802A-63/0.3	A	0.3	2CSB802101R3630	2920205	0.3	1
2	63	DDA802A-63/0.5	A	0.5	2CSB802101R4630	2920403	0.3	1
2	63	DDA802AS-63/0.3	AS	0.3	2CSB802201R3630	2920601	0.3	1
2	63	DDA802AS-63/1	AS	1	2CSB802201R5630	2920809	0.3	1
2	63	DDA802A-63/0.03AP-R	A-AP-R	0.03	2CSB802401R1630	2921400	0.3	1
2	100	DDA802A-100/0.3	A	0.3	2CSB802101R3000	2545033	0.42	1
2	100	DDA802A-100/0.5	A	0.5	2CSB802101R4000	2542636	0.42	1
2	100	DDA802AS-100/0.3	AS	0.3	2CSB802201R3000	2542537	0.42	1
2	100	DDA802AS-100/1	AS	1	2CSB802201R5000	2547433	0.42	1
2	100	DDA802A-100/0.03AP-R	A-AP-R	0.03	2CSB802401R1000	2544630	0.42	1
3	63	DDA803AC-63/0.03	AC	0.03	2CSB803001R1630	2922001	0.4	1
3	63	DDA803AC-63/0.3	AC	0.3	2CSB803001R3630	2922209	0.4	1
3	63	DDA803A-63/0.03	A	0.03	2CSB803101R1630	2922308	0.4	1
3	63	DDA803A-63/0.3	A	0.3	2CSB803101R3630	2922506	0.4	1
3	63	DDA803A-63/0.5	A	0.5	2CSB803101R4630	2922704	0.4	1
3	63	DDA803AS-63/0.3	AS	0.3	2CSB803201R3630	2922902	0.4	1
3	63	DDA803AS-63/1	AS	1	2CSB803201R5630	2923206	0.4	1
3	63	DDA803A-63/0.03AP-R	A-AP-R	0.03	2CSB803401R1630	2923800	0.4	1
3	100	DDA803A-100/0.3	A	0.3	2CSB803101R3000	2544135	0.64	1
3	100	DDA803A-100/0.5	A	0.5	2CSB803101R4000	2541738	0.64	1
3	100	DDA803AS-100/0.3	AS	0.3	2CSB803201R3000	2544838	0.64	1
3	100	DDA803AS-100/0.5	AS	0.5	2CSB803201R4000	2542438	0.64	1
3	100	DDA803AS-100/1	AS	1	2CSB803201R5000	2547334	0.64	1
3	100	DDA803A-100/0.03AP-R	A-AP-R	0.03	2CSB803401R1000	2542230	0.64	1
4	63	DDA804AC-63/0.03	AC	0.03	2CSB804001R1630	2924401	0.46	1
4	63	DDA804AC-63/0.3	AC	0.3	2CSB804001R3630	2924609	0.46	1
4	63	DDA804A-63/0.03	A	0.03	2CSB804101R1630	2924807	0.46	1
4	63	DDA804A-63/0.3	A	0.3	2CSB804101R3630	2925002	0.46	1
4	63	DDA804A-63/0.5	A	0.5	2CSB804101R4630	2925200	0.46	1
4	63	DDA804AS-63/0.3	AS	0.3	2CSB804201R3630	2926207	0.46	1
4	63	DDA804AS-63/1	AS	1	2CSB804201R5630	2926504	0.46	1
4	63	DDA804A-63/0.03AP-R	A-AP-R	0.03	2CSB804401R1630	2927709	0.46	1
4	100	DDA804A-100/0.3	A	0.3	2CSB802101R3000	2545033	0.77	1
4	100	DDA804A-100/0.5	A	0.5	2CSB802101R4000	2542636	0.77	1
4	100	DDA804AS-100/0.3	AS	0.3	2CSB804201R3000	2544739	0.77	1
4	100	DDA804AS-100/0.5	AS	0.5	2CSB804201R4000	2542339	0.77	1
4	100	DDA804AS-100/1	AS	1	2CSB804201R5000	2547235	0.77	1
4	100	DDA804A-100/0.03AP-R	A-AP-R	0.03	2CSB804401R1000	2547136	0.77	1

S800

Accessories

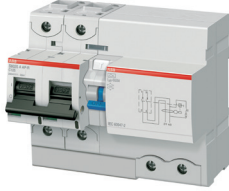

2CCC41325F0001

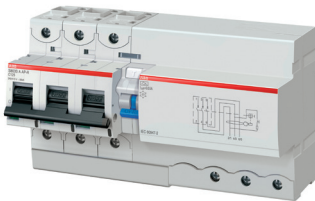

2CCC41325F0001

Quantity	Rated current [A]	Order details	Type	$I_{\Delta n}$	Order code	GTIN EAN 76122712	Weight [kg]	Pack. unit
Pole		Type Code						
2	125	DS802S-B125/0.03AP-R	A-AP-R	0.03	2CCB862004R0845	11301	0.79	1
2	125	DS802S-C125/0.03AP-R	A-AP-R	0.03	2CCB862004R0844	11318	0.79	1
2	125	DS802S-D125/0.03AP-R	A-AP-R	0.03	2CCB862004R0841	11325	0.79	1
2	125	DS802S-K125/0.03AP-R	A-AP-R	0.03	2CCB862004R0647	11332	0.79	1
2	125	DS802N-B125/0.03AP-R	A-AP-R	0.03	2CCB892004R0845	11424	0.79	1
2	125	DS802N-C125/0.03AP-R	A-AP-R	0.03	2CCB892004R0844	11431	0.79	1
2	125	DS802N-D125/0.03AP-R	A-AP-R	0.03	2CCB892004R0841	11448	0.79	1
2	125	DS802S-B125/1AS	AS	1	2CCC862006R0845	11516	0.79	1
2	125	DS802S-C125/1AS	AS	1	2CCC862006R0844	11523	0.79	1
2	125	DS802S-D125/1AS	AS	1	2CCC862006R0841	11530	0.79	1
2	125	DS802S-K125/1AS	AS	1	2CCC862006R0647	11547	0.79	1
2	125	DS802N-B125/1AS	AS	1	2CCC892006R0845	11639	0.79	1
2	125	DS802N-C125/1AS	AS	1	2CCC892006R0844	11646	0.79	1
2	125	DS802N-D125/1AS	AS	1	2CCC892006R0841	11653	0.79	1
2	125	DS802S-B125/0.3A	A	0.3	2CCA862005R0845	11721	0.79	1
2	125	DS802S-C125/0.3A	A	0.3	2CCA862005R0844	11738	0.79	1
2	125	DS802S-D125/0.3A	A	0.3	2CCA862005R0841	11745	0.79	1
2	125	DS802S-K125/0.3A	A	0.3	2CCA862005R0647	11752	0.79	1
2	125	DS802N-B125/0.3A	A	0.3	2CCA892005R0845	11844	0.79	1
2	125	DS802N-C125/0.3A	A	0.3	2CCA892005R0844	11851	0.79	1
2	125	DS802N-D125/0.3A	A	0.3	2CCA892005R0841	11868	0.79	1
3	125	DS803S-B125/0.03AP-R	A-AP-R	0.03	2CCB863004R0845	11349	1.14	1
3	125	DS803S-C125/0.03AP-R	A-AP-R	0.03	2CCB863004R0844	11356	1.14	1
3	125	DS803S-D125/0.03AP-R	A-AP-R	0.03	2CCB863004R0841	11363	1.14	1
3	125	DS803S-K125/0.03AP-R	A-AP-R	0.03	2CCB863004R0647	11370	1.14	1
3	125	DS803N-B125/0.03AP-R	A-AP-R	0.03	2CCB893004R0845	11455	1.14	1
3	125	DS803N-C125/0.03AP-R	A-AP-R	0.03	2CCB893004R0844	11462	1.14	1
3	125	DS803N-D125/0.03AP-R	A-AP-R	0.03	2CCB893004R0841	11479	1.14	1
3	125	DS803S-B125/0.3A	A	0.3	2CCA863005R0845	11769	1.14	1
3	125	DS803S-C125/0.3A	A	0.3	2CCA863005R0844	11776	1.14	1
3	125	DS803S-D125/0.3A	A	0.3	2CCA863005R0841	11783	1.14	1
3	125	DS803S-K125/0.3A	A	0.3	2CCA863005R0647	11790	1.14	1
3	125	DS803N-B125/0.3A	A	0.3	2CCA893005R0845	11875	1.14	1
3	125	DS803N-C125/0.3A	A	0.3	2CCA893005R0844	11882	1.14	1
3	125	DS803N-D125/0.3A	A	0.3	2CCA893005R0841	11899	1.14	1

S800

Accessories

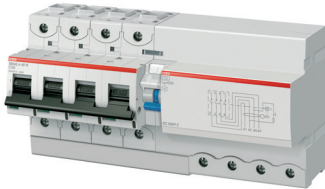

2CCC41329F0001

Quantity	Rated current [A]	Order details	Type	$I_{\Delta n}$	Order code	GTIN EAN 76122712	Weight [kg]	Pack. unit
Pole		Type Code						
4	125	DS804S-B125/0.03AP-R	A-AP-R	0.03	2CCB864004R0845	11387	1.44	1
4	125	DS804S-C125/0.03AP-R	A-AP-R	0.03	2CCB864004R0844	11394	1.44	1
4	125	DS804S-D125/0.03AP-R	A-AP-R	0.03	2CCB864004R0841	11400	1.44	1
4	125	DS804S-K125/0.03AP-R	A-AP-R	0.03	2CCB864004R0647	11417	1.44	1
4	125	DS804N-B125/0.03AP-R	A-AP-R	0.03	2CCB894004R0845	11486	1.44	1
4	125	DS804N-C125/0.03AP-R	A-AP-R	0.03	2CCB894004R0844	11493	1.44	1
4	125	DS804N-D125/0.03AP-R	A-AP-R	0.03	2CCB894004R0841	11509	1.44	1
4	125	DS804S-B125/0.3AS	AS	0.3	2CCC864005R0845	11554	1.44	1
4	125	DS804S-C125/0.3AS	AS	0.3	2CCC864005R0844	11561	1.44	1
4	125	DS804S-D125/0.3AS	AS	0.3	2CCC864005R0841	11578	1.44	1
4	125	DS804S-K125/0.3AS	AS	0.3	2CCC864005R0647	11585	1.44	1
4	125	DS804S-B125/1AS	AS	1	2CCC864006R0845	11592	1.44	1
4	125	DS804S-C125/1AS	AS	1	2CCC864006R0844	11608	1.44	1
4	125	DS804S-D125/1AS	AS	1	2CCC864006R0841	11615	1.44	1
4	125	DS804S-K125/1AS	AS	1	2CCC864006R0647	11622	1.44	1
4	125	DS804N-B125/0.3AS	AS	0.3	2CCC894005R0845	11660	1.44	1
4	125	DS804N-C125/0.3AS	AS	0.3	2CCC894005R0844	11677	1.44	1
4	125	DS804N-D125/0.3AS	AS	0.3	2CCC894005R0841	11684	1.44	1
4	125	DS804N-B125/1AS	AS	1	2CCC894006R0845	11691	1.44	1
4	125	DS804N-C125/1AS	AS	1	2CCC894006R0844	11707	1.44	1
4	125	DS804N-D125/1AS	AS	1	2CCC894006R0841	11714	1.44	1
4	125	DS804S-B125/0.3A	A	0.3	2CCA864005R0845	11806	1.44	1
4	125	DS804S-C125/0.3A	A	0.3	2CCA864005R0844	11813	1.44	1
4	125	DS804S-D125/0.3A	A	0.3	2CCA864005R0841	11820	1.44	1
4	125	DS804S-K125/0.3A	A	0.3	2CCA864005R0647	11837	1.44	1
4	125	DS804N-B125/0.3A	A	0.3	2CCA894005R0845	11905	1.44	1
4	125	DS804N-C125/0.3A	A	0.3	2CCA894005R0844	11912	1.44	1
4	125	DS804N-D125/0.3A	A	0.3	2CCA894005R0841	11929	1.44	1

FONLEE
豐立自動控制器材有限公司
www.fonlee.com.tw

Properties of main devices S800

Characteristics	2/3
Special features of S800	2/9

Properties of S800 accessories

S800-AUX	2/21
S800-AUX/ALT	2/21
S800-NT	2/22
S800-RSU	2/22
S800-RSU-CP	2/23
S800-RSU-P	2/23
S800-SOR	2/23
S800-UVR	2/23
S803S-SCL	2/23
S800-SCL-SR	2/24
S800-RD	2/25
S800-IP9	2/25
S800-PLL	2/25
S800U-PLL	2/26
S800-CT, -RT	2/26
S800-ILS	2/26
S802-LINK50/-LINK125	2/26
DDA800	2/27
S800 Busbar system	2/27
Unifix H	2/27

High Performance MCB S800

Characteristics of the S and N series

Characteristics

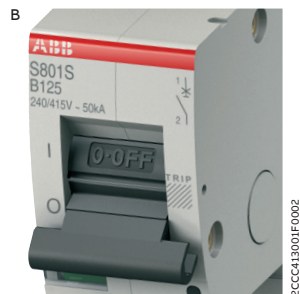

Tripping characteristic B
 Thermal tripping $1.13 \dots 1.3 \times I_n$
 Electromagnetic tripping
 $3 \dots 5 \times I_n$ AC
 Reference temperature 30°C

As circuit breaker for electric circuits feeding consumers that do not generate any current peaks, or only mild ones (boilers, electric heaters, cooking stoves).

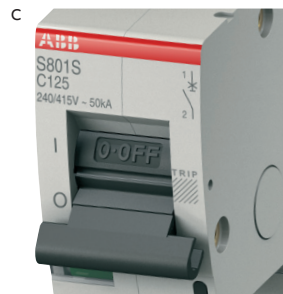

Tripping characteristic C
 Thermal tripping $1.13 \dots 1.3 \times I_n$
 Electromagnetic tripping
 $5 \dots 10 \times I_n$ AC
 Reference temperature 30°C

As "standard" MCB for electric circuits feeding consumers that generate current peaks normal within inductive devices (fluorescent tubes, electric discharge lamps) as well as for circuits within sockets in commercially used systems/plants.

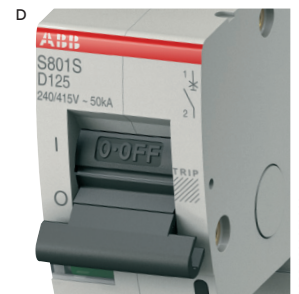

Tripping characteristic D
 Thermal tripping $1.13 \dots 1.3 \times I_n$
 Electromagnetic tripping
 $10 \dots 20 \times I_n$ AC
 Reference temperature 30°C

As main circuit breaker for electric circuits feeding consumers that generate extremely high current peaks (transformers, capacitor banks).
 As main circuit breaker connected upstream of other circuit breakers (reference overcurrent circuit breaker).

Tripping characteristics

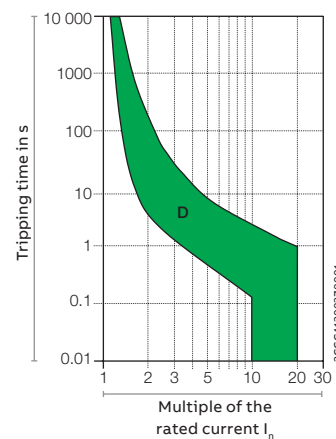
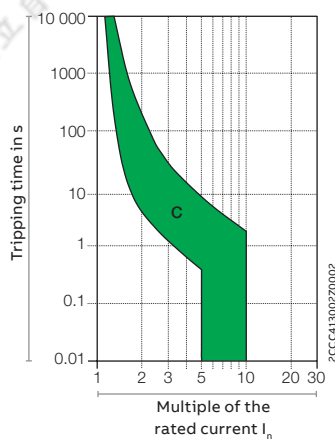
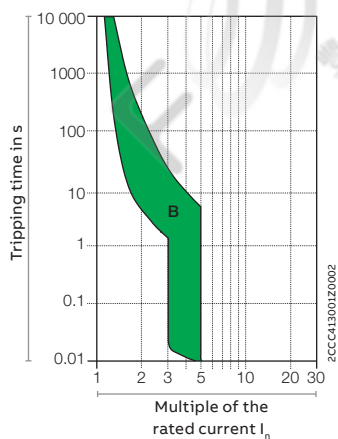

Tripping behaviour compliant to EN 60898-1

Characteristic	Currents	Thermal tripping		Electromagnetic tripping	
		Small test current	Large test current	Small test current	Large test current
B	10 ... 80 A	$1.13 \times I_n$	$1.45 \times I_n$	$3 \times I_n$	$5 \times I_n$
C	10 ... 80 A	$1.13 \times I_n$	$1.45 \times I_n$	$5 \times I_n$	$10 \times I_n$
D	10 ... 80 A	$1.13 \times I_n$	$1.45 \times I_n$	$10 \times I_n$	$20 \times I_n$

* applies exclusively to the S series.

Characteristics

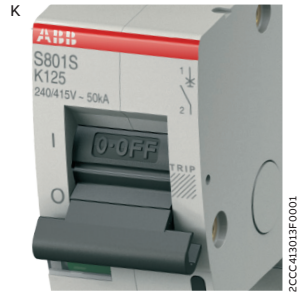

Tripping characteristic K
 Thermal tripping 1.05 ...1.2x I_n
 Electromagnetic tripping
 13x I_n AC
 Reference temperature 40°C

Serves as High Performance MCB in case of high magnetic inrush currents that occur, e.g. in engines or transformers. This characteristic provides the best protection for a wide range of electrical systems by allowing high inrush currents when starting up the system.



Tripping characteristic UCB
 Thermal tripping 1.05 ...1.3x I_n
 Electromagnetic tripping
 6x I_n DC
 Reference temperature 30°C

Device protection independent of polarity within DC plants up to 750 V dc (1000 V dc up to 50 A) = at a time constant of ≤15ms.



Tripping characteristic UCK
 Thermal tripping 1.05 ...1.2x I_n
 Electromagnetic tripping
 11x I_n DC
 Reference temperature 40°C

Device protection independent of polarity within DC plants up to 750 V dc (1000 V dc up to 50 A) = at a time constant of ≤15ms.

Tripping characteristics

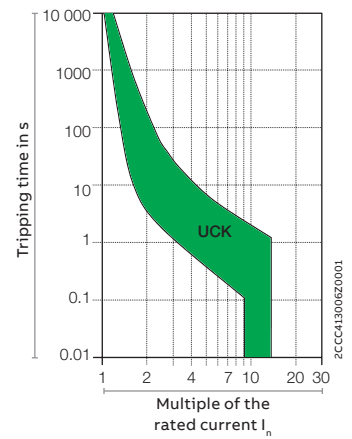
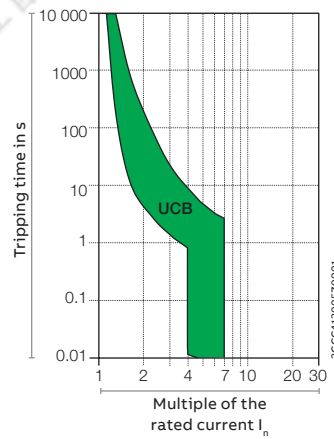
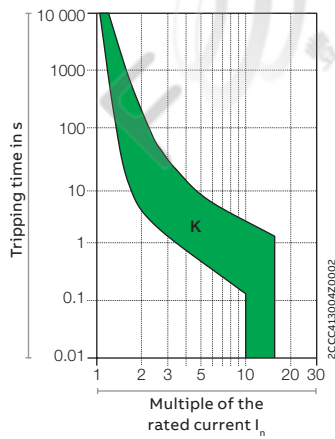

Tripping behaviour compliant to IEC 60947-2

Characteristic	Currents	Thermal tripping		Electromagnetic tripping
		Small test current	Large test current	
B	0.5 ... 125 A	1.05 x I _n	1.30 x I _n	4 x I _n ± 20%
C	0.5 ... 125 A	1.05 x I _n	1.30 x I _n	8 x I _n ± 20%
D	0.5 ... 125 A	1.05 x I _n	1.30 x I _n	13 x I _n ± 20%
K*	0.5 ... 125 A	1.05 x I _n	1.20 x I _n	13 x I _n ± 20%
KM*	10 ... 80 A			13 x I _n ± 20%
UCB*	0.5 ... 80 A	1.05 x I _n	1.30 x I _n	6 x I _n ± 20% (DC)
UCK*	0.5 ... 80 A	1.05 x I _n	1.20 x I _n	11 x I _n ± 20% (DC)

High Performance MCB S800

Characteristics of the B and C series

Characteristics

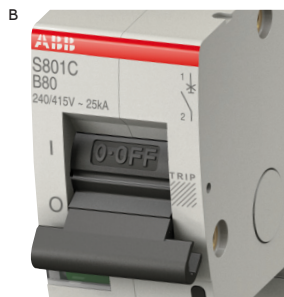

Tripping characteristic B
 Thermal tripping $1.13 \dots 1.3 \times I_n$
 Electromagnetic tripping
 $3 \dots 5 \times I_n$ AC
 Reference temperature 30°C

As circuit breaker for electric circuits feeding consumers that do not generate any current peaks, or only mild ones (boilers, electric heaters, cooking stoves).

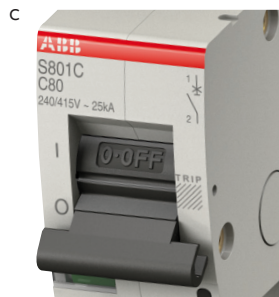

Tripping characteristic C
 Thermal tripping $1.13 \dots 1.3 \times I_n$
 Electromagnetic tripping
 $5 \dots 10 \times I_n$ AC
 Reference temperature 30°C

As "standard" MCB for electric circuits feeding consumers that generate current peaks normal within inductive devices (fluorescent tubes, electric discharge lamps) as well as for circuits within sockets in commercially used systems/plants.

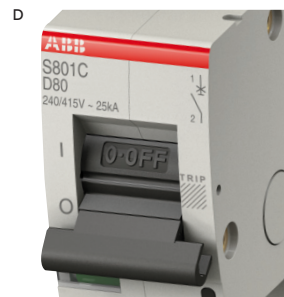

Tripping characteristic D
 Thermal tripping $1.13 \dots 1.3 \times I_n$
 Electromagnetic tripping
 $10 \dots 20 \times I_n$ AC
 Reference temperature 30°C

As main circuit breaker for electric circuits feeding consumers that generate extremely high current peaks (transformers, capacitor banks).
 As main circuit breaker connected upstream of other circuit breakers (reference overcurrent circuit breaker).

Tripping characteristics

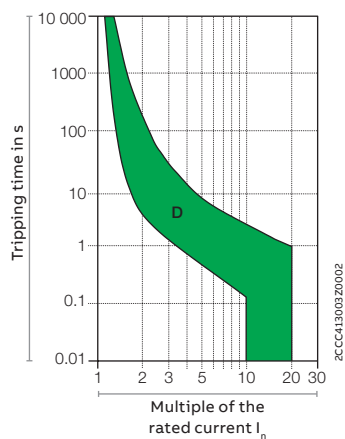
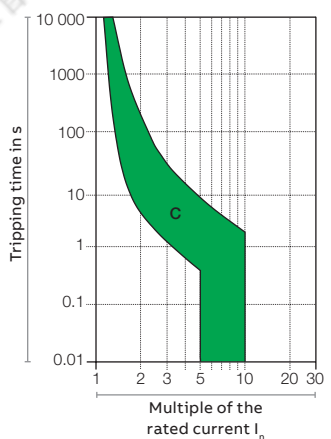
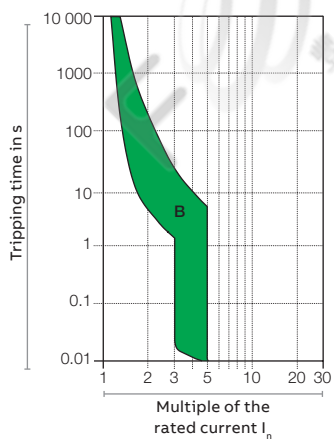

Tripping behaviour compliant to 60898-1

Characteristic	Currents	Thermal tripping		Electromagnetic tripping	
		Small test current	Large test current	Small test current	Large test current
B	10 ... 125 A	$1.13 \times I_n$	$1.45 \times I_n$	$3 \times I_n$	$5 \times I_n$
C	10 ... 125 A	$1.13 \times I_n$	$1.45 \times I_n$	$5 \times I_n$	$10 \times I_n$
D	10 ... 100 A	$1.13 \times I_n$	$1.45 \times I_n$	$10 \times I_n$	$20 \times I_n$

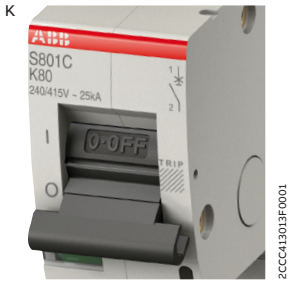

Tripping characteristic K
 Thermal tripping $1.05 \dots 1.2 \times I_n$
 Electromagnetic tripping $13 \times I_n$ AC
 Reference temperature 40°C

Serves as High Performance MCB in case of high magnetic inrush currents that occur, e.g. in engines or transformers. This characteristic provides the best protection for a wide range of electrical systems by allowing high inrush currents when starting up the system.

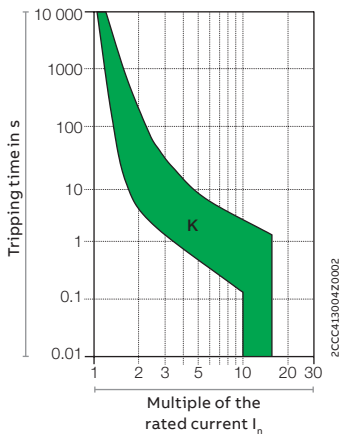

Tripping behaviour compliant to IEC 60947-2

Characteristic	Currents	Thermal tripping		Electromagnetic tripping
		Small test current	Large test current	
B	$10/32^* \dots 125$ A	$1.05 \times I_n$	$1.30 \times I_n$	$4 \times I_n \pm 20\%$
C	$10/32^* \dots 125$ A	$1.05 \times I_n$	$1.30 \times I_n$	$8 \times I_n \pm 20\%$
D	$10/32^* \dots 125$ A	$1.05 \times I_n$	$1.30 \times I_n$	$13 \times I_n \pm 20\%$
K	$10/32^* \dots 125$ A	$1.05 \times I_n$	$1.20 \times I_n$	$13 \times I_n \pm 20\%$

* applies for S800B

High Performance MCB S800

Characteristics of U series

Characteristics

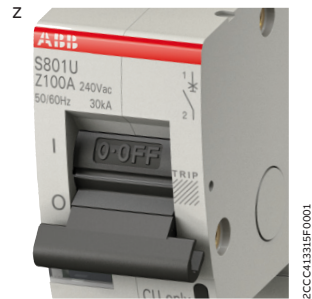

Tripping characteristic Z
 Thermal tripping $1.00 \dots 1.35 \times I_n$
 Electromagnetic tripping
 $4 \times I_n$ AC
 Reference temperature 25°C

As miniature circuit breaker for electric circuits feeding consumers that do not generate any current peaks, or only mild ones.

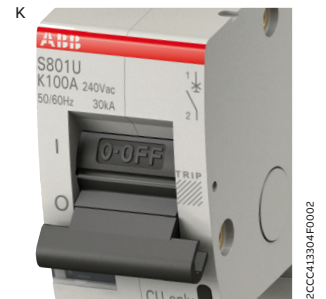

Tripping characteristic K
 Thermal tripping $1.00 \dots 1.35 \times I_n$
 Electromagnetic tripping
 $13 \times I_n$ AC
 Reference temperature 25°C

Serves as High Performance MCB in case of high magnetic inrush currents that occur, e.g. in engines or transformers. This characteristic provides the best protection for a wide range of electrical systems by allowing high inrush currents when starting up the system.

Tripping characteristics

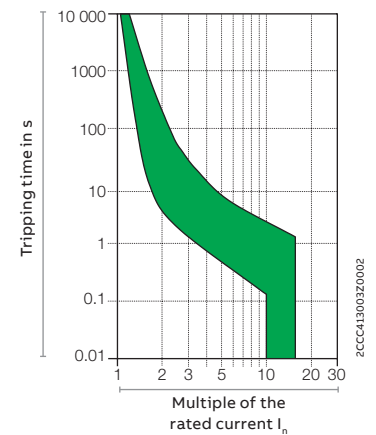
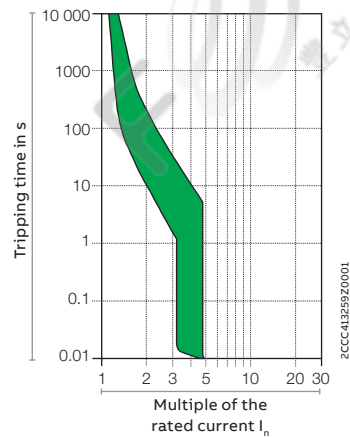

Tripping behaviour compliant to UL 489

Characteristic	Currents	Thermal tripping		Electromagnetic tripping
		Small test current	Large test current	
Z	10 ... 100 A	$1.00 \times I_n$	$1.35 \times I_n$	$4 \times I_n \pm 20\%$
K	10 ... 100 A	$1.00 \times I_n$	$1.35 \times I_n$	$13 \times I_n \pm 20\%$

High Performance MCB S800

Characteristics of the S804U-UCZ, S804U-PVS5

Characteristics



Tripping characteristic
 Thermal tripping 1.00 ... 1.35 x I_n
 Electromagnetic tripping 11 x I_n
 Reference temperature 25 °C

As circuit breaker for voltages up to 600VDC, especially in datacenters.



Tripping characteristic
 Thermal tripping 1.13 ... 1.3 x I_n
 Electromagnetic tripping 6 x I_n
 Reference temperature 50 °C

As Ground-Fault Detector Interrupter (GFDI) in photovoltaic systems.

Tripping characteristics

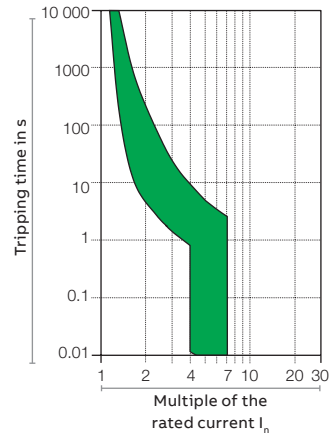
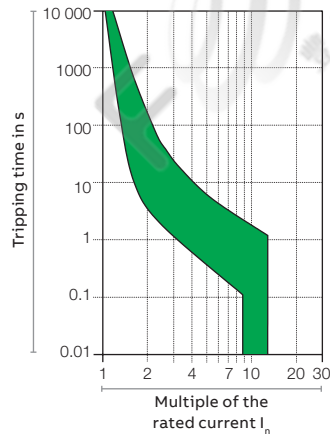

Tripping behaviour compliant to UL 489B

Characteristic	Currents	Thermal tripping		Electromagnetic tripping
		Small test current	Large test current	
PVS	5 A	1.13 x I _n	1.30 x I _n	6 x I _n (DC)

Tripping behaviour compliant to UL 489

Z	10...80 A	1.00 x I _n	1.35 x I _n	11 x I _n (DC) ± 20%
---	-----------	-----------------------	-----------------------	--------------------------------

Photovoltaic High Performance MCB

Characteristic of the S800PV-SP

Characteristics



Tripping characteristic

Thermal tripping $1.05 \dots 1.3 \times I_n$
 Electromagnetic tripping $6 \times I_n$
 Reference temperature 30°C

DC protection independent of polarity in photovoltaic plants up to 1500 V DC at a time constant ≤ 5 ms.

Tripping characteristics

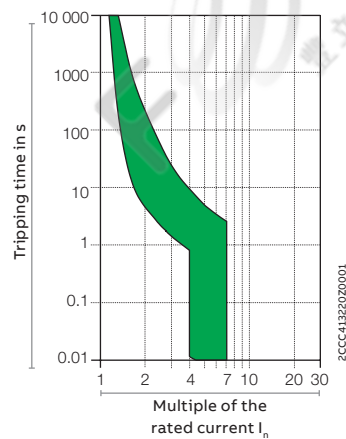

Tripping behaviour compliant to IEC 60947-2

Characteristic	Currents	Thermal tripping		Electromagnetic tripping
		Small test current	Large test current	
PV-SP	5 ... 125 A	$1.05 \times I_n$	$1.30 \times I_n$	$6 \times I_n$ (DC)

Properties

Special features of S800



2CCC413001F0002

The S800S, -N, -C, -B and -HV high performance MCBs: safe innovation

The S800 high performance MCB limits energy and current in case of a short-circuit power cut off. The specially designed double arcing chamber system, i.e. per pole are two arcing chambers, ensures excellent operating characteristics. The new S800B has only one arcing chamber. Additional exceptional features of the S800 series are:

- Convincing: Selectivity to upstream overcurrent protection devices due to a total switch-off time of only ≤ 2.5 ms.
- Safe: Excellent backup protection by limiting the energy to a value $\leq 100\,000\text{ A}^2\text{s}$ (125A/50kA). In case of short-circuit, there is a low load to the circuit and the location of the damage due to the high limitation of the let-through energy.
- Loads: Up to 125A rated current
- Checked: S series up to 50kA rated ultimate short-circuit breaking capacity I_{cu}
N series up to 36kA rated ultimate short-circuit breaking capacity I_{cu}
C series up to 25kA rated ultimate short-circuit breaking capacity I_{cu}
B series up to 16kA rated ultimate short-circuit breaking capacity I_{cu}
HV series up to 4kA rated ultimate short-circuit breaking capacity I_{cu}
- Selectable: Characteristics:
- S series: B, C, D, K, KM, UCB, UCK
- N series: B, C, D
- C series: B, C, D, K
- B series: B, C, D, K
- HV series: C, K
- Compact: Slight 27 mm width per pole
- Flexible: Accessories installed by the customer.



S800U: Highest safety now also ensured for UL applications

- Convincing: Covering of different voltage ranges (240VAC, 600VDC, 1000VDC)
- Safe: Excellent backup protection due to limitation of energy.
- Loads: Up to 100A rated current
- Checked: K-, Z series up to 50kA breaking capacity
UCZ series up to 10kA breaking capacity
PVS series up to 3kA breaking capacity
- Selectable: Characteristics:
K, Z, UCZ, PVS
- Compact: Smallest sizes.
- Flexible: Accessories installed by the customer.
- Standards: UL489, UL489B, IEC 60947-2

Short description

Two triggers detect overcurrents, effect the switching station and provide short-circuit protection.

1. The thermal trip for overload protection with time delay.
2. The electromagnetic fast-acting trip with concrete anchor for short-circuit protection.

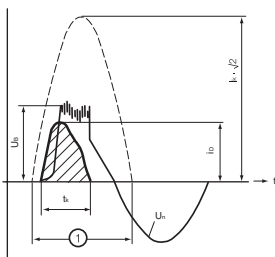

2CCC41319420002

① 1 sinus half-wave
50 Hz T/2 = 10 ms

- $I_k \times \sqrt{2}$ peak value of the prospective short-circuit current
- i_D max. let-through current of the S800 high performance MCB
- U_n supply voltage
- U_b build up and collapse of the arc voltage
- t_k Turn-off time of S800 high performance MCB

Properties

Special features of S800



Play it safe: display the operational state

The mechanical drive of the S800 high performance MCB is equipped with a trip-free release. It therefore switches independent of the actuating force or speed on the actuating lever. The trip position display thereby always reliably displays the exact position of the moving contact. The trip position provides additional trip detection allowing you to easily find the reason for the cut-off. Because the switch lever moves to the middle position in case of thermal or magnetic tripping, the user sees at a glance that this is an error state and can then initiate suitable measures.

*Middle position of switch lever, see picture

Reliable: the disconnecter properties

In OFF position (0 position), the S800 high performance MCB guarantees safe electrical isolation of the circuit compliant to IEC 60947-2.

Flexible: the installation

The S800 high performance MCB can be directly mounted onto any position on the DIN mounting rail without any impairment to its characteristics. Because the pole dimensions are identical for all rated currents, installation in switching systems is simplified.

The S800 can be installed in different ways:

- together with other breakers in the same DIN rail horizontally or vertically
- as an individual breaker in a single fixed compartment where the breaker is switched on/off with a rotary handle from the door, and the breaker is mounted on the wall of the panel
- as an individual breaker in a single withdrawable module, when requirements for high availability in the installation are a must

Cage and ring terminals

When ordering you can choose between cage terminals or ring terminal connectors. No matter which type you select, both connection options guarantee a high degree of reliability.

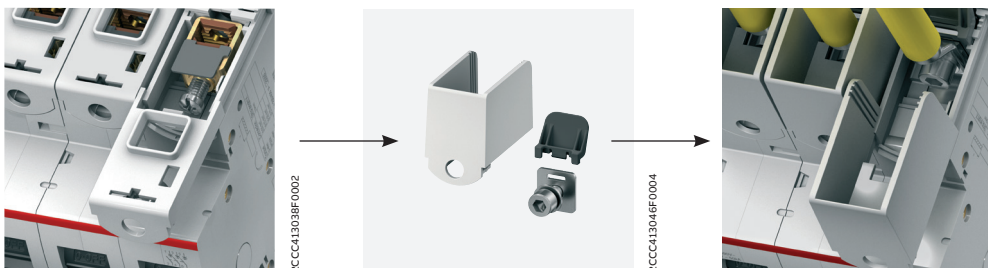

Doesn't let go: the replaceable terminal adapter*

The S800 standard equipment with interchangeable terminal adapter for wires, cables and rigid conductors guarantees a high level of flexibility and comfort. Fast and safe connection of the conductors is ensured by the "onboard terminal shutter" integrated into the body of the terminal, thereby preventing incorrect underclamping of the connections.

* Available for the S, N, C, U and PV series.

Properties

Special features of S800



Extra safe: Fire protection acc. to NF F 16-101 and NF F 16-102 (prEN45545-2)

The S800 high performance MCB provides standard compliance to the requirements of Standard prEN45545-2 (Railway applications – Fire Protection on railway vehicles – Part 2: Requirements for fire behaviour of materials and components). This standard is based on the French standard NF F 16-101/ NF F 16-102 and makes new requirements of the fire behaviour of the materials used. The main focus of attention with relation to fire protection is on the following:

- Flame spread
- Rate of heat release
- Smoke development
- Toxicity

The S800 high performance automatic meets the following classification compliant to NF F 16-101 and NF F 16-102:

- I3F2
- I3 no permanent flame at 850°C
- F2 index of fume density and toxicity ≤ 40

More information regarding the use of S800 breakers in rolling stock applications is available in the Technical catalogue 'DIN-Rail components for rolling stock applications 2CDC002053D0204'



Elevation

Up to 2000 meters above sea level, the rated characteristics of the S800 high performance MCB remain unchanged. With increasing height, the properties of the atmosphere change regarding composition, dielectricity, the cooling capacity and the pressure. Thus for altitudes over 2000m below values are valid.

Elevation	[m]	2000	3000	4000	5000
Rated impulse withstand voltage U_{imp}	[kV]	8	6	6	6
Rated operational voltage U_e	[V]	690	600	540	470
Max. rated current I_n	[A]	$1 \times I_n$	$0.96 \times I_n$	$0.93 \times I_n$	$0.9 \times I_n$

CMS – Circuit Measurement System



The CMS is a compact AC and DC multi-channel branch monitoring system, consisting of a control unit and sensors. The components can be easily installed and clearly arranged inside control and distribution cabinets, with minimum space requirements.

The design of the system guarantees reliability, maximum ease of use, a wide measurement range (up to 160 A), and maximum scalability in any application, from critical power to buildings.

Moreover, the high modularity and flexibility of the CMS system makes it easy to upgrade and expand the solution at any time, ideal for retrofit applications in existing systems.

Properties

DC Performance



S800S-UC: The first choice as DC high performance MCB

The S800S-UC DC high performance MCB is in a wide range of DC applications at home. Due to their high rated operational voltage of up to 1000VDC the max. rated current of 125A and the high breaking capacity of up to 50 kA, make these devices suitable for applications, e.g.:

- DC track
- Galavanic applications
- Photovoltaics

S800S, N, and C: Up to 125VDC on each pole

The AC range is also an interesting choice for DC applications up to 125VDC per pole.

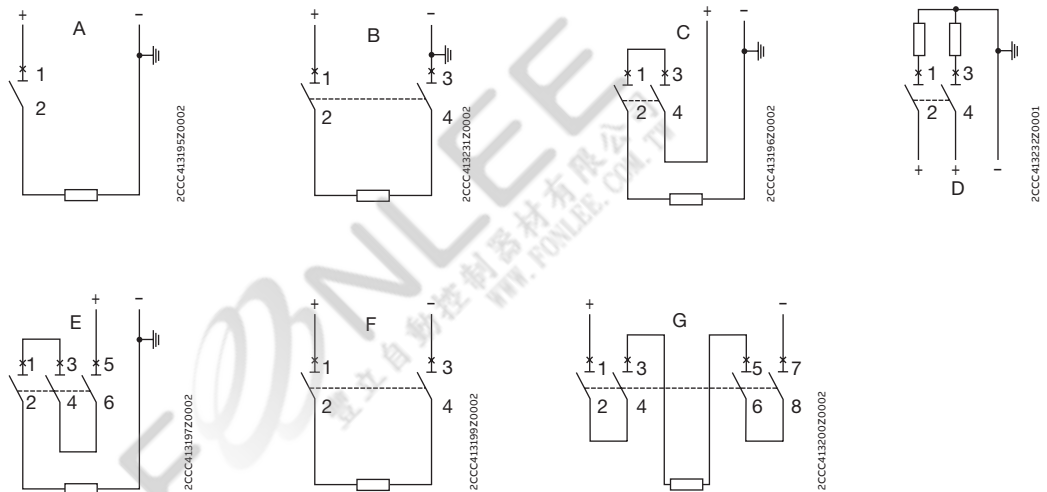

S800S-UC

Graphic	Short-circuit between output terminals	Contact to ground between output terminals and - earth
A	250VDC	250VDC
B	500VDC	250VDC
C	500VDC	500VDC
D	250VDC	250VDC
E	750VDC	750VDC
F	500VDC	250VDC (double failure)
G	750 V DC / 1000 V DC	500VDC (double failure)

S800S, S800N, S800C

Graphic	Short-circuit between output terminals	Contact to ground between output terminals and - earth
A	125VDC	125VDC
B	250VDC	125VDC
C	250VDC	250VDC
D	125VDC	125VDC
E	375VDC	375VDC
F	250VDC	125VDC (double failure)
G	500VDC	125VDC (double failure)

Properties

Special features of S800PV-SP, S800PV-SD



String protection with S800PV-SP

A large proportion of the costs for photovoltaic systems is tied up in the equipment for the DC generation. The S800PV-SP protects these investments in the event of a fault.

- Convincing: Suitable for up to 1500 VDC
- Loadable: String protection up to 125 A
Reliable protection at high ambient temperatures
- Tested: Rated ultimate short-circuit breaking capacity I_{cu} of 5 kA in accordance with IEC 60947-2 and Annex P
- Fast: Reclosable for minimum standstill times
- Safe: Disconnecter properties, switching under load
- Flexible: Extensive range of accessories for remote shutdown and fault signalling



System isolation with S800PV-SD

The use of a DC isolator can be implemented reliably and in the minimum of space. Either you can choose the pole-independent S800PV-SD. The S800PV-SD is available as 2-, 3- and 4-pole version up to 1500 V DC.

- Convincing: Suitable for up to 1500 VDC
- Loadable: System isolation up to 125 A
No change in operating behaviour up to 60°C ambient temperature
Reliable switching of ohmic loads including moderate overloads
- Compact: Minimum dimensions with maximum efficiency
- Tested: Short-time withstand current I_{cw} of 1.5 kA in accordance with IEC 60947-3
- Safe: Disconnecter properties, switching under load

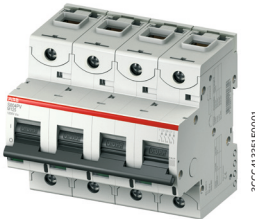

Maximum device voltages

Article	2-pole	3-pole	4-pole
S800PV-SP			
I _e 5 ... 125A	800 VDC	1200 VDC	1500 VDC
S800PV-SD			
I _e 32, 63, 125A	800 VDC	1200 VDC	1500 VDC

ABB recommends to fulfill national and/or international standards as e.g. IEC 61439-1 Low-voltage switchgear and controlgear assemblies

Exemplary circuit diagrams

Earthed network

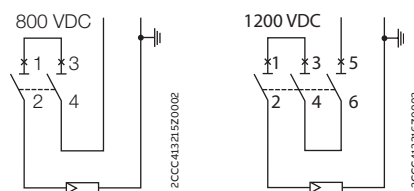

Non-earthed network

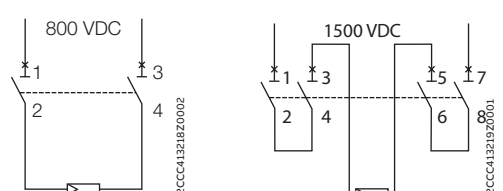

Properties

S804U-PVS5 High performance MCB for GFDI

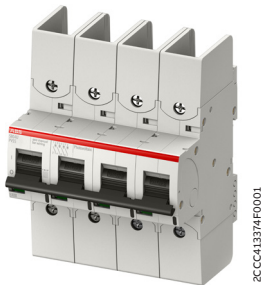

GFDI = Ground Fault Detector Interrupter

The S804U-PVS5 is for GFDI application (Ground-Fault Detector Interrupter) in photovoltaic systems, with rated current 5A and short-circuit current rating of 3kA. The breaker is tested acc. to UL489B for 1000VDC.

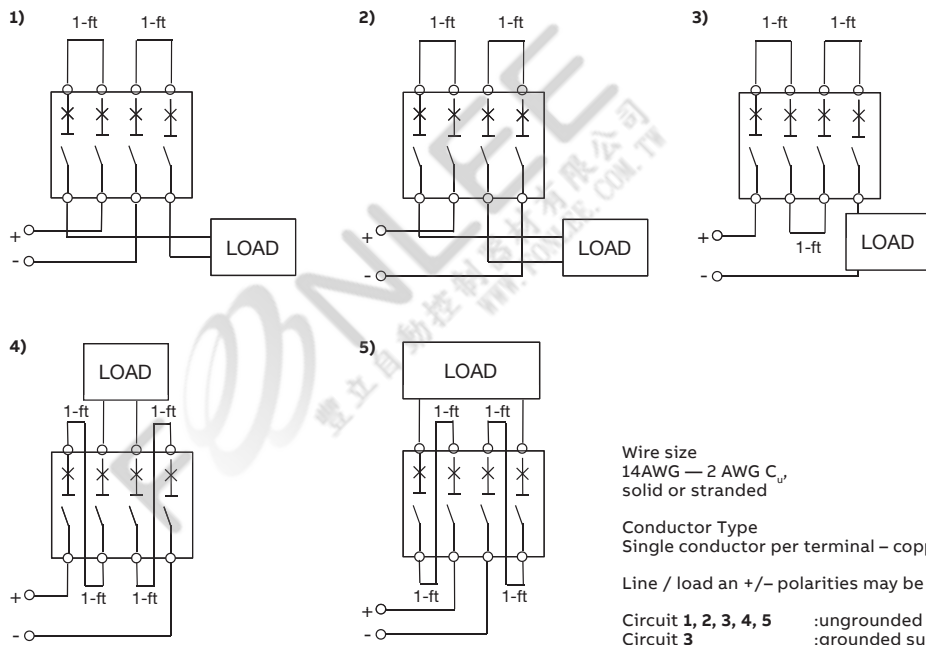

Properties

Special features of S800-RSU



S800 with S800-RSU

Known for its outstanding short circuit capacities of up to 50kA and voltages of up to 690 VAC and 1200VDC, S800 has become a convenient solution for the DIN Rail. S800-RSU makes the use of S800 even more convenient: driven by a brushless high precision DC motor, S800-RSU ensures fast remote-controlled operation. Wiring and operation is easy: S800-RSU can be operated with standard MDRC pushbuttons and indicator lights or via programmable logic controllers (PLCs). Due to its low power consumption, compact power supply units can be chosen.

Applications and Benefits:

Photovoltaics: Remote-controlled string management and convenient GFDI solutions

For a new generation of combiner boxes: used as a substitute for string or array fuses, S800PV or S804U-PVS5 in combination with S800-RSU ensures maximum PV yield due to minimum downtimes in case of failure or maintenance. For selective string management, additional switch disconnectors are no longer needed. S800-RSU adds to S800PV or S804U-PVS5 outstanding benefits for the PV-industry, allowing automated ground fault detection and interruption applications following UL1741.

Critical Power: Uninterrupted Power Supply Units

Fast, reliable backup protection for UPS systems: S800-RSU provides outstanding quality and performance by switching a backup system quickly and reliably at extremely low stand-by current.

Telecommunications: Remote transmitter substations

The Remote Switching Units RSU minimize time-consuming visits to remote substations. Downtimes can be kept low due to convenient remote resetting of a tripped High Performance MCB.

Wind Power: Turbine towers

Inaccessible areas like wind turbine towers require immediate action in the case of overload or short circuits. The automatic switching capability of the High Performance MCB leads to reduction of cost-intensive fuse replacement or manual resetting of circuit breakers.

Product Facts:

- Driven by Swiss-made brushless high precision DC motors
- Field mountable on any multi-pole S800 High Performance MCB
- Almost all accessories can be mounted
- Short switching times and low power consumption
- Mechanically lockable
- Compatible to ABB pro M compact 9mm pushbuttons and indicator lights
- Compatible to ABB Programmable Logic Controllers
- User safety due to hand-switching recognition
- Low stand-by current
- Connecting has to be done by a 10-pole Micro Fit 3.0 plug (not included in delivery)
- Two versions
 - S800-RSU-H IEC-Version according to IEC 60947-2
 - S800W-RSU World version according to IEC 60947-2 and UL489

Properties

Special features of S800S-SCL-SR

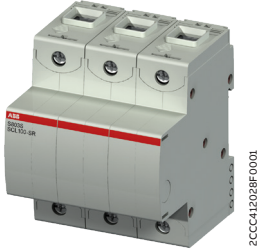

ZCCC412028F0001

Group protection

In comparison to other short-circuit limiter you need only one S800S-SCL-SR for several motor starters or high performance miniature circuit breakers. With the requirement that the rated current of the short-circuit limiter does not exceed the total sum of the rated S800S currents of all downstream motor starters or circuit breakers. Furthermore the sum of all load currents including inrush currents shall not exceed the maximum permissible load of the S800S-SCL-SR. Therefore the main application of the new S800S-SCL-SR is group protection. Several downstream motor protection combinations or several high performance miniature circuit breakers can be protected with only one S800S-SCL-SR.

Single-line protection

For single-line protection we recommend to use the standard short-circuit limiter S803S-SCL. It has a toggle and will trip in case of a failure.

Current continuity

In case of a failure by using the S800S-SCL-SR as group protection only the defective device will trip; all other devices will keep doing their work. Therefore you will have a very low breakdown, because only one motor will stop and not all of them.

Maximum system availability is given.

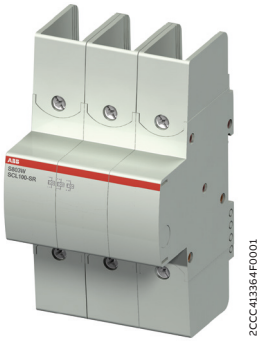

ZCCC413364F0001

Schematic examples for rated currents up to 100 A

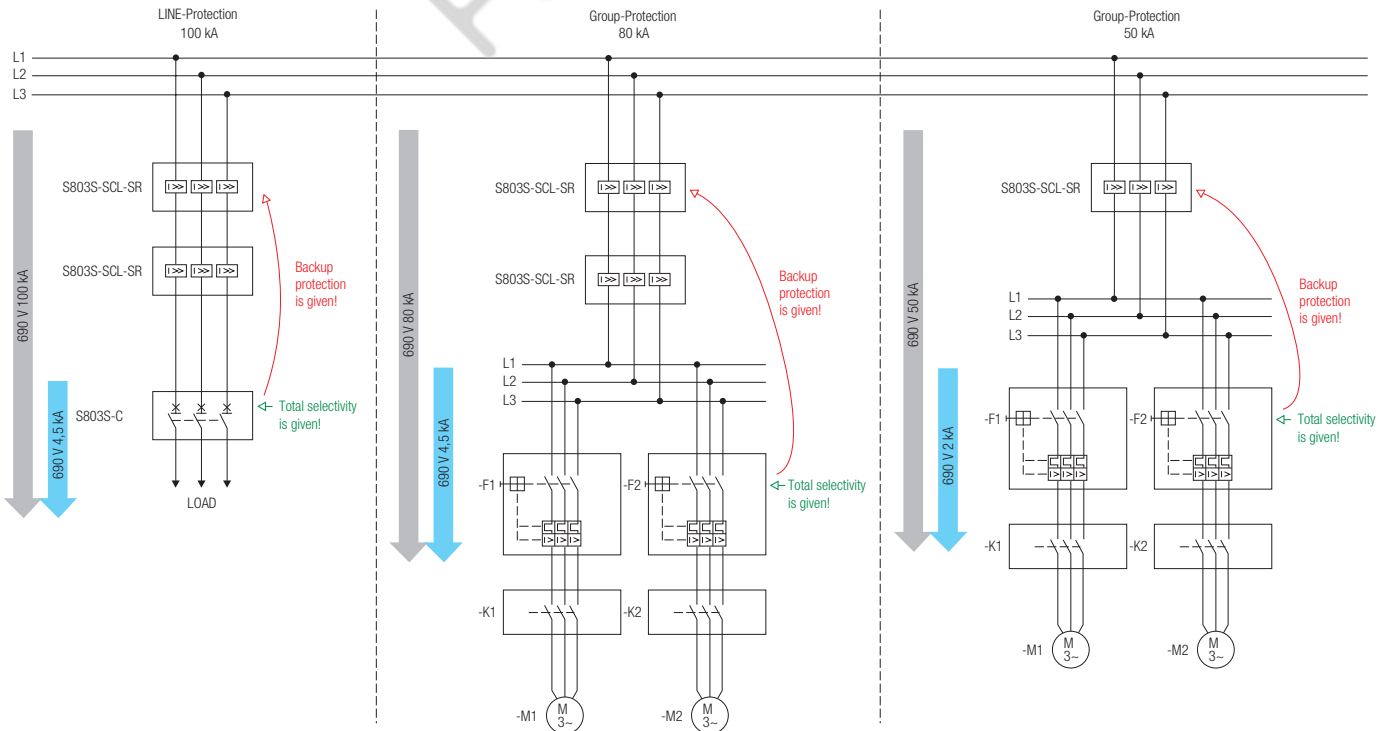

→ Short-circuit breaking capacity only downstream device
→ Short-circuit breaking capacity coordinated group S800S-SCL-SR

Properties

Special features of S800HV-SCL-SR

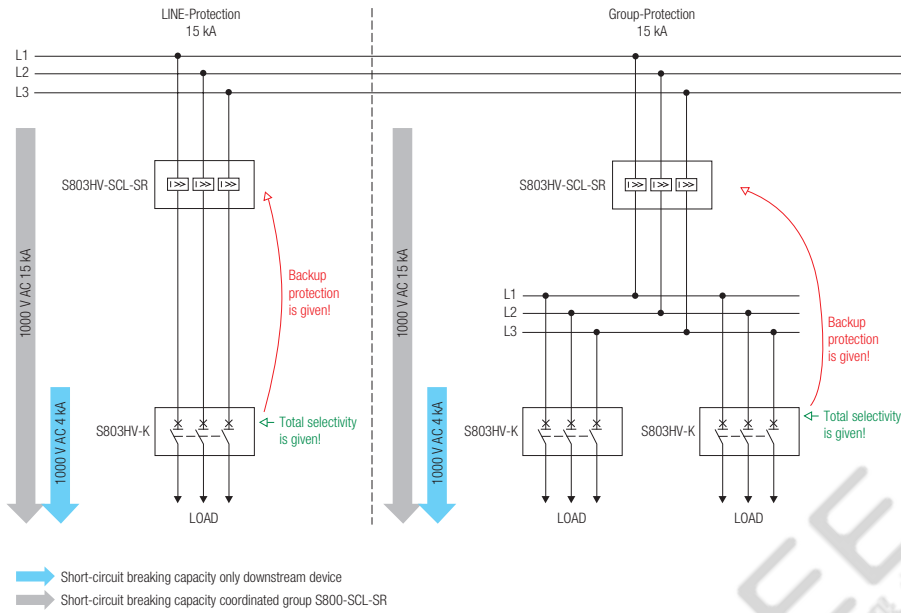

FONLEEE
 豐立自動控制器材有限公司
 www.FONLEEE.COM.TW

Properties

International device releases

Unique: Conformity to standards and quality assurance

Both the S800 high performance MCB as well as its accessories comply to international standards EN/IEC 60898-1, IEC 60947-2 and UL 489. Conformity to the above-mentioned product standards and guidelines are certified by the electrosuisse, a member of the IECEE and the Underwrites Laboratories Inc. The quality assurance system of ABB Switzerland Ltd. Low Voltage Products complies to the international standard ISO 9001:2000. The efforts of ISO14001-certified ABB Switzerland Ltd. Low Voltage Products within the field of environmental protection are not only limited to compliance to international standards; we are also engaged and active of our own accord in protecting the environment – and for achieving the targets of reduction in CO2 emissions we have received as confirmation the EnAW label of the economic energy agency. To retain this label, an independent check is made every two years.

We are committed to a holistic approach in the reduction of environmental pollution. Among other things, this is manifested in our choice of non-toxic plastics, recyclable packaging material and environmentally sound handling of resources.

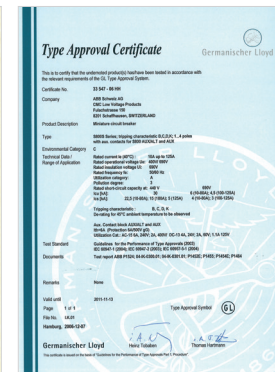
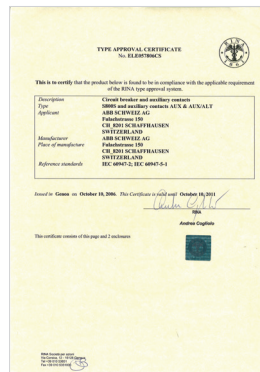
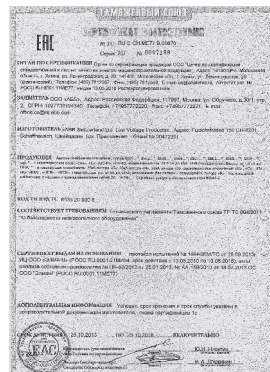
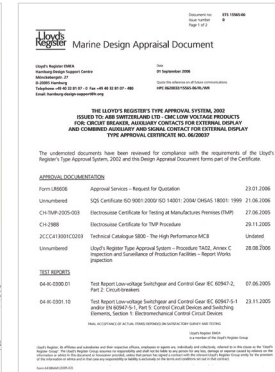
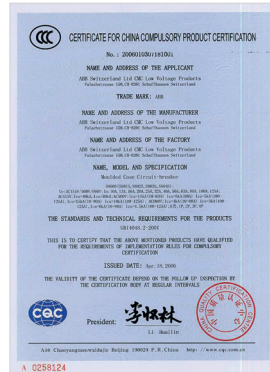
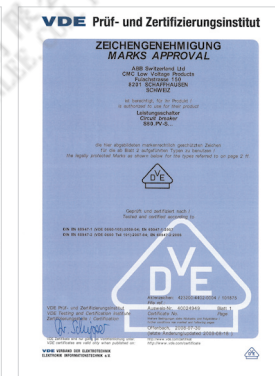

Approvals

Properties

Accessories

Electrical properties

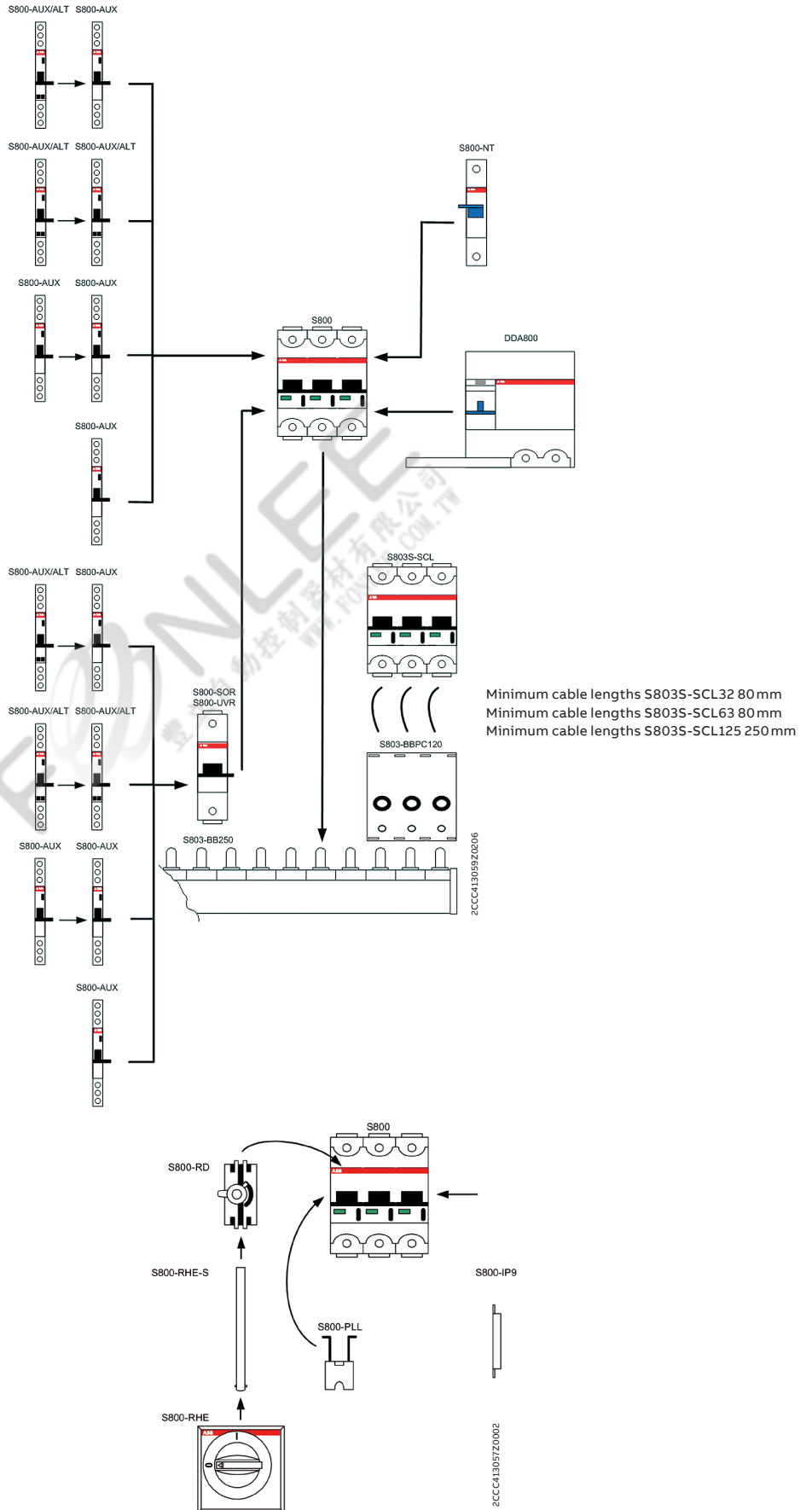

Properties

Accessories



ZCCC413069F0001



S800-AUX

Auxiliary contact for external display

The S800-AUX auxiliary contact is for electrical display of the operating state of the high performance MCB. Both changeover contacts always switch simultaneously with the live conductor contact and detect the following operating states:

- Manual tripping
- Tripping due to thermal overload
- Tripping due to magnetic overload (short-circuit)

Mode of function of the test button

The test button is operated by a tool and allows the user to simulate the mode of function of the auxiliary contact when switched on without tripping the high performance MCB itself.

Mode of function of the two changeover contacts

- Off position of the high performance MCB contacts 11–12 and 21–22 closed
- On position of the high performance MCB contacts 11–14 and 21–24 closed

Mounting ability of the auxiliary contact

- Two S800-AUX auxiliary contacts can be mounted by the user at the left on the high performance MCB.

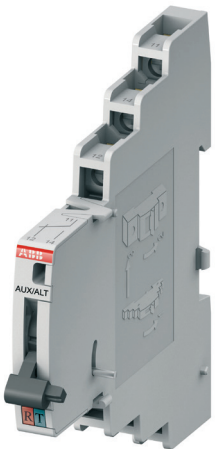

ZCCC413070F0001



S800-AUX/ALT

Combined auxiliary and signal contact for the external display

The S800-AUX/ALT combined auxiliary and signal contact is used for electrical signaling of the operating state of the high performance MCB.

The AUX auxiliary contact always switches simultaneously with the live conductor contact and detect the following forms of tripping:

- Manual switch on/off
- Tripping due to thermal overload
- Tripping due to magnetic overload (short-circuit)
- Tripping by S800-SOR or S800-UVR

The ALT signal contact detects the following forms of tripping of the high performance MCB:

- Tripping due to thermal overload
- Tripping due to magnetic overload (short-circuit)
- Tripping by S800-SOR or S800-UVR

Mode of function of the test button

The test button is operated by a tool and allows the user to simulate the mode of function of the combined auxiliary and signal contact when switched on without tripping the high performance MCB itself.

Mode of function of the ALT reset button

The reset button, which can be used at will, resets the ALT signal contact after a tripping. The high performance MCB is switched on independent of the state of the ALT signal contact.

Mode of function of the AUX changeover contact

- Off position of the high performance MCB Contact 11–12 closed
- On position of the high performance MCB Contact 11–14 closed

Mode of function of the ALT changeover contact

- No ALT tripping Contact 95–96 closed
- ALT tripping Contact 95–98 closed

Properties
Accessories



2CCCA13067F0001

S800-NT

Disconnectable neutral conductor 63A

The S800 high performance MCB is force-opened before actuating the disconnectable neutral conductor S800-NT.

Mounting ability of the S800-NT neutral conductor

The neutral conductor can be mounted by the user at the right on the high performance MCB.



2CCCA13353F0001

S800-RSU-H IEC version
S800W-RSU World version

Remote Switching Units for High Performance MCB

The S800-RSU makes the use of S800 even more convenient. Driven by a brushless high precision DC motor, S800-RSU ensures fast remote-controlled operation.

Mounting ability

The S800-RSU is mountable on any multipole S800 High Performance MCB. Wiring and operation is feasible on field. The connection has to be done by a 10-pole Micro Fit 3.0 (not included in delivery). S800-RSU operated with standard MDRC pushbuttons and indicator lights or can be done via programmable logic controllers (PLCs).

Switching times

OFF → ON <<500 ms
from signal to contact closing

ON → OFF <<250 ms
from signal to contact opening

TRIP → OFF → ON <<1500 ms
from signal to contact closing

For differing requirements, please contact your local ABB partner

Safety Intelligence

- When detecting manual use, inputs are deactivated for 10 seconds
- If the spindle is rotated more than 360°, all outputs become active
- Manual switch off via lever is possible (S803, S804)
- Manual switch on via lever is not possible (S802)
- RSU is locked for five minutes after three switching attempts leading to a trip
- Mechanical fixation via lock slider blocking the spindle

Properties

Accessories



2CCC41357F0001

S800-RSU-CP

S800-RSU cable incl. 10-pole Micro Fit 3.0 plug

Length of cable: 3 m
 Cross section: 10 x 0.5 mm²

Temperature range

moving state: -5 °C ... +70 °C
 fixed state: -30 °C ... +80 °C
 Rated voltage: 300 V
 Conductor resistance: 39.0 Ω/km
 Approvals: S+, UL

S800-RSU-P

10-pole Micro Fit 3.0 plug

10-pole Micro Fit 3.0 plug with 12 loose crimped contacts. You need tongs for connecting.



2CCC413239F0001

S800-SOR

Shunt opening release

The S800-SOR shunt opening release is for remote release of the S800- high performance MCB using an electrical impulse. Operation of the trigger is guaranteed at a voltage between 70 % and 110 % of the rated mains voltage U_n both for AC and DC.

Mounting ability of the S800-SOR operating current release

The S800-SOR can be mounted by the user at the left side of the high performance MCB.



2CCC413240F0001

S800-UVR

Undervoltage release

The S800-UVR undervoltage release can be used as an emergency-stop cut-as by use of suitable emergency stop buttons. The undervoltage release switches the power supply to the high performance MCB off in case of a failure or if the value falls below $0.7 \times U_n$. After tripping, the high performance MCB can be switched back on as soon as the voltage is over $0.85 \times U_n$.

Mounting ability of the S800-UVR undervoltage release

The S800-UVR can be mounted by the user at the left side of the high performance MCB.

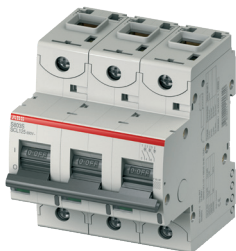

2CCC41308F0002

S803S-SCL

Short-circuit current limiter

The S803S used together with an S803S-SCL ensures reliable switch-off of short-circuit currents up to **100 kA**, at an operating voltage of 440V AC and over the entire rated current range of up to 125 A.

For applications at 690V AC, the combination of S803S-SCL ensures reliable short-circuit protection up to **50 kA**; here also, this is ensured over the entire rated current range up to 125 A, typical for the S800.

Example combinations	Rated operational voltage U_e	Ultimate short-circuit breaking capacity I_{cu}	Service short-circuit breaking capacity I_{cs}
S803S-SCL125 + S803S-C125	440V AC 690V AC	100 kA 50 kA	100 kA 50 kA
S803S-SCL63 + S803S-K63	440V AC 690V AC	100 kA 50 kA	100 kA 50 kA
S803S-SCL32 + S803S-B16	440V AC 690V AC	100 kA 50 kA	100 kA 50 kA

Properties
Accessories



2CCC412028F0001

S800-SCL-SR

Self-resetting short-circuit limiter

The S800-SCL-SR can be used together with S800S High Performance MCB or Manual Motor Starters. It limits the short-circuit current until the downstream means of protection trips. Its current continuity makes it as the ideal solution for group protection. All parallel branches remain operative.

**Minimum cable length between S800-SCL-SR/S803S-SCL and downstream devices
(Connection has to be short-circuit proofed acc. to IEC 61439-1)**

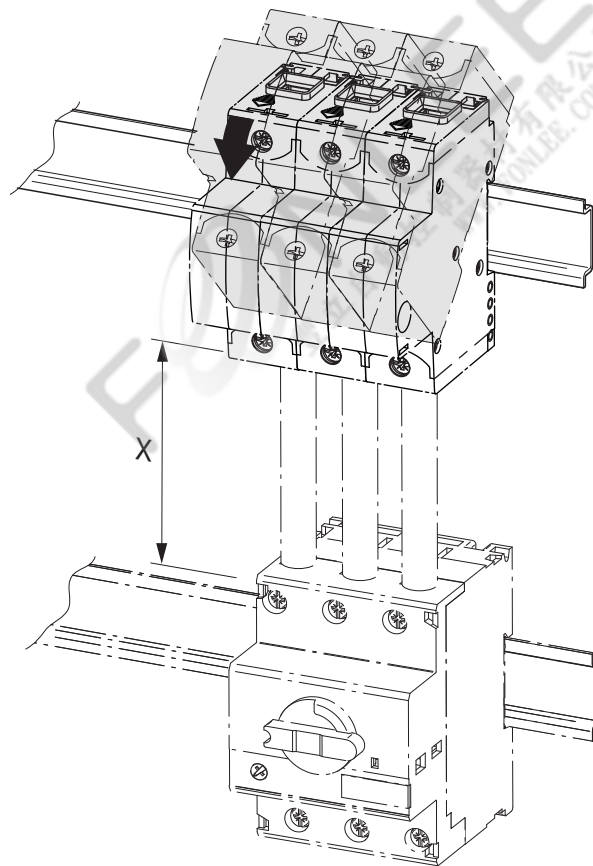

2CCC413280Z0001

MS/M0325
MS/M0132
S800

S800-SCL-SR/S803S-SCL	min. length X	min. cross section
32A	80 mm	6 mm ²
63A	80 mm	16 mm ²
100/125A	250 mm	35 mm ²

Properties

Accessories



2CCC413062F0001

S800-RD

Rotary drive

The rotary drive for 2–4 pole devices can be delivered for assembly on the switching field door. Switching is effortless due to the ergonomic design of the swivel lever. It is equipped with a lock for the OFF position that prevents switching on of the S800 high performance MCB. The slot hole of the lock can accept up to 3 padlocks with lug diameters of 7 mm (not included in delivery). Operation of the trigger and a view of the characteristics are not prevented. Additionally, a rotary drive can also be supplied to switch machines; it has a red grip on a yellow background.

The rotary drive on the switching field door is comprised of the following three components:

- Rotary handle S800-RHE-H, -EM
- Axle (500 mm) S800-RHE-S



2CCC413068F0001

S800-IP9

Intermediate piece

The S800-IP9 intermediate piece fits the profile of the high performance MCB and is used to fill in empty device slots. Thanks to its width of just 9mm, the slots of all devices of the S800 range can be expanded using this intermediate piece.



2CCC413066F0001

S800-PLL

Padlock device

The S800-PLL padlock device safely prevents unintentional switching on and off. Simply insert the lug of the padlock device through the borehole on the high performance MCB and lock with a padlock with lug diameter \varnothing 4 mm (not included in delivery). Even when the high performance MCB is secured with a padlock device against unintentional switching off, tripping remains possible in case of overload or short-circuit by the S800-SOR, S800-UVR and DDA800.



2CCC413308F0001

S800U-PLL

Locking device – for the American market

The S800U-PLL locking device prevents unintentional switch-on or off of the S800U high performance MCB, or switch on/off by third parties. It is mounted at the side of the high performance MCB and can only be removed using a special tool. A standardised American padlock (not included in delivery) is hung onto the round recess on the locking device, which can be secured by max six locks. Of course, tripping is possible by the S800-SOR or S800-UVR in case of overload or short-circuit.

Properties
Accessories

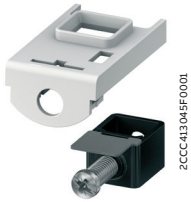

S800-CT, -RT

Interchangeable adapter kit

The S800 interchangeable adapter kit allows the cable clamp – ring terminal connections to be exchanged. Ring terminal connection -> Cage Terminal connection

The following is included in the S800-CT replaceable interchangeable adapter kit:

- Cage terminal
- Insulator

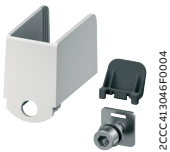

Cage Terminal connection -> ring terminal connection

The following is included in the S800-RT replaceable interchangeable adapter kit:

- Nut, insulation nut – cable lug, Allen screw
- Insulator with 25 mm insulation walls

S800-ILS

Identification labelling system

The individual identification labelling system for ILS legend plates is a DIN A5 polyester foil for inkjet and laser printers with high temperature resistance (if a laser printer is used please check whether self-sticking foils with a thickness of 250 μm can be printed with it). The 3M™9471 LE adhesive backing is UL-approved with Appl. No. MH 11410. The single plates are butt-cut on one side. Can be manually labelled with ink, pen, pencil and felt pen.

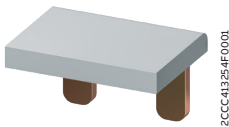

S802-LINK50

Pole connector up to 50 A

The pole connector S802-LINK50 can be used up to 50 A.



S802-LINK125

Pole connector up to 125 A

The pole connector S802-LINK125 can be used up to 125 A.

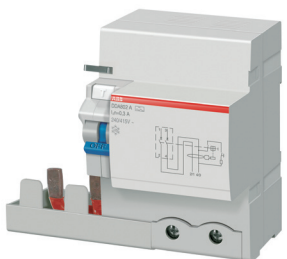

DDA800

RCD Block

RCD blocks from the DDA800 family can be connected to the S800 high performance MCB. The DDA800 can be used both for sine-shaped AC fault currents (type AC) as well as for pulsed DC fault currents (type A). Typical ABB: Selective and short-term delay devices are also available. The functionality of the switching device can be checked at any time with the test button. The DDA800 switches ensure effective protection against fire and explosion. Devices with $I_n \leq 30 \text{ mA}$ guarantee the protection of persons against shock currents caused by both direct and indirect touching in addition to the obligatory safety measures prescribed by the safety and accident-prevention regulations.

The DDA800 blocks comply to standard:

- IEC/EN 60947-2 Annex B

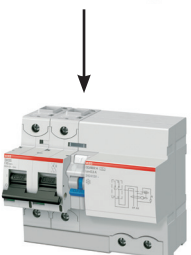

Mounting ability of the DDA800 RCD blocks

The leakage current trigger can be mounted by the user at the right of the live conductor.

Properties

Accessories

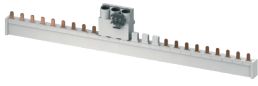

2CCC413060F0001

S800 Busbar system

The S800 busbar system is comprised of:

- S804-BBPC120 120 mm² feed block, 4-pole
- S804-BB250 250A busbar, 4-pole and neutral with 24 contacts pins
- S804-BB6 250A busbar, 4-pole with 6 contacts pins
- S803-BB250 250A busbar, 3-pole with 24 terminal lugs and 2 end caps
- S803-BBPC120 120 mm² feed block, 3-pole
- S800-BBIC Optional contact-protection cap for exposed terminal lugs
- S800-END Optional end cap

The busbar, which can be shortened in length by the user, ensures the safe and rational connection of the S800 high performance MCB. A cable cross-section of up to 120 mm² can be connected at the feed block.



2CCC413048F0001

Unifix H

The Unifix H System with feed module up to 400A provides the user a high standardised design of energy distribution. The wide range of assembly and adapter combinations which are also available for the S800 range increase flexibility allowing for compact and cost-effective design of the electrical distribution network.

The following adapters are available for the S800 range:

- ED2557 L1 ≤32A
- ED2558 L2 ≤32A
- ED2559 L3 ≤32A
- ED2560 N ≤32A
- ED2551 L1 125A
- ED2552 L2 125A
- ED2553 L3 125A
- ED2554 N 125A
- ED2550 filler

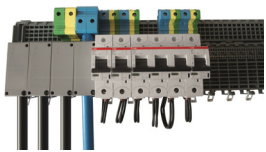

2CCC451731F0001

27mm wide universal adapter to mount S800 MCB on SMISLINE TP system

The universal adapter with the new 9mm dummy housing is specially designed for the High performance breaker S800. This allows to have a 27mm adapter on the SMISLINE TP busbar system. The S800 High performance MCB can be easily mounted and wired on the universal adapter. The complete unit can be clicked on to the plug-in socket system quickly and safely. The input wiring is then already finished.

- Max. Incoming 400A (T5/XT5) rated conditional short-circuit current I_{cc} 40kA (415V) with S800S
- Time-saving mounting of S800 MCB units up to 30% faster than conventional DIN rail mounting
- Input wiring is already integrated in the SMISLINE plug-in socket system

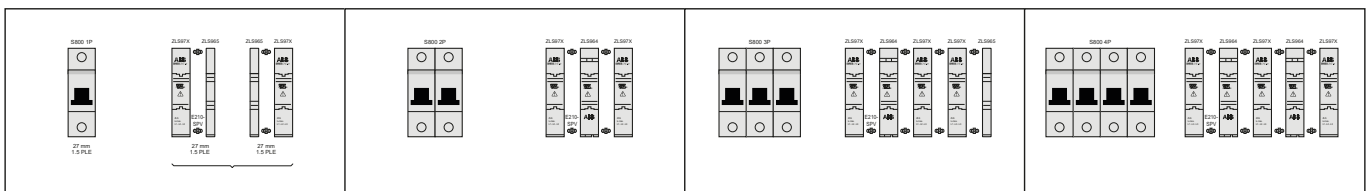

Properties

Definitions

Rated short-circuit capacity I_{cn}

Compliant to EN 60898-1

The maximum current which a switching device can switch off without damage at a rated operational voltage and rated operational frequency. It is specified as an effective value.

Rated ultimate short-circuit breaking capacity I_{cu}

Compliant to EN 60947-2

Ultimate short-circuit breaking capacity that a circuit breaker can switch off without damage at a rated operational voltage and rated operational frequency. It is specified as an effective value.

Rated service short-circuit breaking capacity I_{cs}

Compliant to EN 60947-2

Service short-circuit breaking capacity that a circuit breaker can switch off without damage at a rated operational voltage and rated operational frequency. It is specified as an effective value.

Rated insulation voltage U_i

The rated insulation voltage is the voltage to which dielectric checks and creepage distances refer. The maximum rated operational voltage must not exceed its rated insulation voltage.

Rated impulse withstand voltage U_{imp}

Peak of a withstand voltage of a specified form and polarity with which the circuit can be loaded under specified test conditions without a breakdown and to which clearances relate. The rated impulse withstand voltage must be equal to or greater than the values of the withstand over-voltages (transient overvoltages) which occur in the System in which the device is used.

Backup protection

Assignment of two overcurrent protective devices in series, where the protective device, generally but not necessarily on the supply side, effects the overcurrent protection with or without the assistance of the other protective device and prevents excessive stress on the latter [IEC 60947-1, definition 2.5.24].

Total selectivity

Overcurrent discrimination where, in the presence of two overcurrent protective devices in series, the protective device on the load side effects the protection without causing the other protective device to operate [IEC 60947-2, definition 2.17.2].

Partial selectivity

Overcurrent discrimination where, in the presence of two overcurrent protective devices in series, the protective device on the load side effects the protection up to a given level of overcurrent, without causing the other protective device to operate [IEC 60947-2, definition 2.17.3].

FONLEE
豐立自動控制器材有限公司
www.fonlee.com.tw

Technical data of S800

S800S	3/3
S800N	3/6
S800C	3/8
S800B	3/10
S800HV	3/11
S800U	3/13
S800PV	3/17
Accessories	3/22

Let-through energies

S800S-B, -C, -D, -K	3/39
S800N-B, -C, -D	3/42
S800C-B, -C, -D, -K	3/43
S800B-B, -C, -D, -K	3/44
S800U-K, -Z	3/45

Let-through current

S800S-B, -C, -D, -K	3/46
S800N-B, -C, -D	3/49
S800C-B, -C, -D, -K	3/50
S800B-B, -C, -D, -K	3/51
S800U-K, -Z	3/52

FONLEE
 豐立自動控制器材有限公司
 www.fonlee.com.tw

Technical data

S800S

		S800S	S803S-KM	S800S-UC
General Data				
Tripping characteristics		B, C, D, K	KM	UCB, UCK
Standards		IEC/EN 60947-2, EN 60898-1, UL 1077	IEC/EN 60947-2	IEC/EN 60947-2
Poles		1 ... 4	3	1 ... 4
Rated current I_n	A	0.5 ... 125	10 ... 80	0.5 ... 125
Rated frequency f	Hz	50/60	50/60	50/60
Rated insulation voltage U_i acc. to IEC/EN 60664-1	V	AC 690	AC 690	DC 1000
Rated impulse withstand voltage $U_{imp.}$ (1.2/50µs)	kV	8	8	8
Overvoltage category		IV	IV	III
Pollution degree		3	3	2
Suitability for isolation		yes	yes	yes
Data acc. to IEC/EN 60898-1				
Rated operational voltage U_e	V	AC 230/400	-	-
Min. operating voltage	V	AC 12	-	-
Rated short-circuit capacity I_{cn}	kA	Char. B, C, D: 230/400V (10 ... 80A) = 25 kA	-	-
Reference temperature for tripping characteristics	°C	30°C (Char. B, C, D)		
Electrical and Mechanical Endurance	ops	10 ... 32A: 10000 electrical/10000 mechanical 40 ... 80A: 6000 electrical/ 10000 mechanical	-	-
Service short-circuit capacity I_{cs}	kA	Char. B, C, D: 230/400V (10 ... 80A) = 12.5 kA	-	-
Data acc. to IEC/EN 60947-2				
Rated operational voltage U_e	V	AC 400/690 DC 125 (1-pole) DC 250 (2-pole) DC 375 (3-pole) DC 500 (4-pole)	AC 690	DC 250 (1-pole) DC 500 (2-pole) DC 750 (3-pole) DC 750 (4-pole) (63 ... 125 A) DC 1000 (4-pole) (10 ... 50A)
Min. operating voltage	V	AC 12	AC 12	-
Rated ultimate short-circuit capacity I_{cu}	kA	AC 240/415 V = 50 kA AC 254/440 V = 30 kA AC 289/500 V (up to 80 A) = 15 kA AC 289/500 V (100 ... 125 A) = 10 kA AC 400/690 V (up to 80 A) = 6 kA AC 400/690 V (100 ... 125 A) = 4.5 kA DC 125 V (1-pole) = 30 kA DC 250 V (2-pole) = 30 kA DC 375 V (3-pole) = 30 kA DC 500 V (4-pole) = 30 kA	AC 240/415V = 50 kA AC 254/440V = 30 kA AC 400/690V = 6 kA DC 375V = 30 kA	DC 250 V (1-pole) = 50 kA DC 500 V (2-pole) = 50 kA DC 750 V (3-pole) = 50 kA DC 750 V (4-pole) (63...125A) = 50 kA DC 1000V (4-pole)(10...50A) = 50 kA
Rated service short-circuit capacity I_{cs}	kA	AC 240/415 V = 40 kA AC 254/440 V (up to 80 A) = 22.5 kA AC 254/440 V (100 ... 125 A) = 15 kA AC 289/500 V (up to 80 A) = 11 kA AC 289/500 V (100 ... 125 A) = 5 kA AC 400/690 V (up to 80 A) = 4 kA AC 400/690 V (100 ... 125 A) = 3 kA DC 125 V (1-pole) = 30 kA DC 250 V (2-pole) = 30 kA DC 375 V (3-pole) = 30 kA DC 500 V (4-pole) = 30 kA	DC 375V = 30 kA	DC 250 V (1-pole) = 50 kA DC 500 V (2-pole) = 50 kA DC 750 V (3-pole) = 50 kA DC 750 V (4-pole) (63...125A) = 50 kA DC 1000V (4-pole)(10...50A) = 50 kA
Reference temperature for tripping characteristics	°C	B, C, D: 30°C K: 40°C	only magnetic release	UCB: 30°C UCK: 40°C
Electrical and Mechanical Endurance	ops.	0.5 ... 32A: 10000 electrical/ 10000 mechanical 40 ... 100A: 6000 electrical/ 10000 mechanical 125 A: 4000 electrical/ 8000 mechanical	10 ... 32A: 10000 electrical/ mechanical 40 ... 80 A: 6000 electrical/ 10000 mechanical	0.5 ... 100A: 1500 electrical/ 10000 mechanical 125 A: 1000 electrical/ 8000 mechanical
Data acc. to UL 1077/ C22.2 No 235, Supplementary Protector				
Alternating current: int. cap.		1 240: 30 (0.5...63A) 277: 14 (0.5...63A) 347: 6 (0.5...63A) 2,3,4 240: 30 (0.5...63A) 480 Y/277: 14 (0.5...63A) 600 Y/347: 6 (0.5...63A)		

Technical data

S800S

S800S / S803S-KM / S800S-UC		
Mechanical Data		
Housing		Material group I, RAL 7035
Toggle		black, lockable
Classification acc. to NF F 126-101, NF F 16-102		I3, F2
Protection degree acc. to EN 60529		IP20; IP40(actuating end only)
Shock resistance acc. to IEC/EN 60068-2-31		IEC 61373 Cat. 1 Class B, 5g / 30ms acc. to IEC 60068-27 Test Ea
Vibration resistance acc. to IEC/EN 60068-2-6		IEC 60068-2-6 Test Fc; 2 - 13.2Hz / 1 mm 13.2 - 100Hz / 0.7g with load 100% x I _e
Environmental conditions (damp heat) acc. to IEC/EN 60068-2-30	°C/RH	12 + 12 cycle with 55°C/90–96% and 25°C/95–100%
Environmental conditions (dry heat) acc. to IEC/EN 60068-2-2 Test B	°C/RH	16 hours 55°C / 2 hours 70°C with damp heat 55%
Ambient temperature	°C	–25 ... +60
Storage temperature	°C	–40 ... +70
Installation		
Terminal		Failsafe cage or ringlug terminal
Connections (top/bottom) – C _u only	mm ²	1 ... 50 stranded 1 ... 70 flexible
	AWG (S800S only)	10 - 30 A: 14 AWG – 2 AWG 40 - 100 A: 14 AWG – 2 AWG
Tightening torque	Nm	3.5
	in-lbs.	31
Screwdriver		POZI 2
Mounting		EN 60715
Mounting position		any
Supply		any
Dimensions and weight		
Pole dimensions (H x L x W)	mm	82.5 x 95 x 26.5
Pole weight	g	ca. 240

Typical internal resistances and power losses at 25°C ambient temperature (per pole)

Rated current I _n [A]	Internal resistance R _i [mΩ]			Power loss P _v [W]		
	B, C, D, K	KM	UCB, UCK	B, C, D, K	KM	UCB, UCK
0.5	8124.6	-	8124.6	2	-	2
1	1627.2	-	1627.2	1.6	-	1.6
1.6	1118.6	-	1118.6	2.9	-	2.9
2	556.6	-	556.6	2.2	-	2.2
2.5	399.3	-	399.3	2.5	-	2.5
3	270.3	-	270.3	2.4	-	2.4
4	126.4	-	126.4	2	-	2
5	57.9	-	57.9	1.5	-	1.5
6	51.7	-	-	1.8	-	-
8	27.2	-	-	1.7	-	-
10	15.2	-	15.2	1.5	-	1.5
13	12.1	-	12.1	2	-	2
16	12.1	-	12.1	3.1	-	3.1
20	8.7	2.7	8.7	3.5	1.1	3.5
25	6.8	3	6.8	4.3	1.9	4.3
32	3.1	1.7	3.1	3.2	1.7	3.2
40	2.3	1.6	2.3	3.7	2.6	3.7
50	1.7	1.1	1.7	4.3	2.8	4.3
63	1.6	1	1.6	6.4	4	6.4
80	1	0.75	1	6.4	5	6.4
100	0.8	-	0.8	8	-	8
125	0.6	-	0.6	9.4	-	9.4

Technical data

S800S

Maximum permissible earth-fault loop impedance Z_s at U_0 230V* to ensure compliance with the requirements of IEC 60364-4

The instantaneous release of the MCB ensures an operating time of max. 0.1s (TN system). Determined according to IEC 60364-5-52 / VDE 0100-520 and DIN VDE 0100-520 sheet 2:2002 (source impedance 300m Ω , $c = 0.95$ and conductor temperature 70°C = factor 0.8). The internal resistance of the MCB is included. Values below 10 A are available upon request.

* U_0 : rated voltage against earthed conductor; for U_0 : AC 240V multiply Z_s by 1.04, for U_0 : AC 254V multiply Z_s by 1.10, for U_0 : AC 400V multiply Z_s by 1.74

Rated current (A)	B	C max. Z_s (Ω)	D	K
10	4.8	2.4	1.5	1.5
13	3.7	1.8	1.1	1.1
16	3.0	1.5	0.9	0.9
20	2.4	1.2	0.7	0.7
25	1.9	1.0	0.6	0.6
32	1.5	0.7	0.5	0.5
40	1.2	0.6	0.4	0.4
50	1.0	0.5	0.3	0.3
63	0.8	0.4	0.2	0.2
80	0.6	0.3	0.2	0.2
100	0.5	0.2	0.1	0.1
125	0.4	0.2	0.1	0.1

Technical data

S800N

		S800N	
General Data			
Tripping characteristics		B, C, D	
Standards		IEC/EN 60947-2, EN 60898-1	
Poles		1 ... 4	
Rated current I_e	A	6 ... 125	
Rated frequency f	Hz	50/60	
Rated insulation voltage U_i acc. to IEC/EN 60664-1	V	AC 690	
Rated impulse withstand voltage U_{imp} (1.2/50µs)	kV	8	
Overvoltage category		IV	
Pollution degree		3	
Suitability for isolation		yes	
Data acc. to IEC/EN 60898-1			
Rated operational voltage U_e	V	AC 230/400	
Min. operating voltage	V	AC 12	
Rated short-circuit capacity I_{cn}	kA	AC 230/400V (10 ... 80A) = 20kA	
Reference temperature for tripping characteristics	°C	30°C (Char. B, C, D)	
Electrical and Mechanical Endurance	ops	10 ... 32A: 10000 electrical/10000 mechanical 40 ... 80A: 6000 electrical/10000 mechanical	
Service short-circuit capacity I_{cs}	kA	230/400V (10 ... 80A) = 10kA	
Data acc. to IEC/EN 60947-2			
Rated operational voltage U_e	V	AC 400/690 DC 125 (1-pole) DC 250 (2-pole) DC 375 (3-pole) DC 500 (4-pole)	
Min. operating voltage	V	AC 12	
Rated ultimate short-circuit capacity I_{cu}	kA	AC 240/415 V = 36 kA AC 254/440 V = 20 kA AC 289/500 V = 10 kA AC 400/690 V = 4.5 kA DC 125 V (1-pole) = 20 kA DC 250 V (2-pole) = 20 kA DC 375 V (3-pole) = 20 kA DC 500 V (4-pole) = 20 kA	
Rated service short-circuit capacity I_{cs}	kA	AC 240/415 V = 30 kA AC 254/440 V (up to 63 A) = 15 kA AC 254/440 V (80 ... 125 A) = 10 kA AC 289/500 V (up to 80 A) = 8 kA AC 289/500 V (100 ... 125) = 5 kA AC 400/690 V = 3 kA DC 125 V (1-pole) = 20 kA DC 250 V (2-pole) = 20 kA DC 375 V (3-pole) = 20 kA DC 500 V (4-pole) = 20 kA	
Reference temperature for tripping characteristics	°C	30°C	
Electrical and Mechanical Endurance	ops.	6 ... 32A: 10000 electrical/10000 mechanical 40 ... 100A: 6000 electrical/10000 mechanical 125 A: 4000 electrical/8000 mechanical	
Mechanical Data			
Housing		Material group I, RAL 7035	
Toggle		black, lockable	
Classification acc. To NF F 126-101, NF F 16-102		I3, F2	
Protection degree acc. to EN 60529		IP20; IP40 (actuating end only)	
Shock resistance acc. to IEC/EN 60068-2-30		IEC 61373 Cat. 1 Class B, 5g / 30ms acc. To IEC 60068-27 Test Ea	
Vibration resistance acc. to IEC/EN 60068-2-6		IEC 60068-2-6 Test Fc; 2–13.2 Hz/1 mm 13.2–100Hz/0.7g with load 100% x I_e	
Environmental conditions (damp heat) acc. to IEC/EN 60068-2-30	°C/RH	12 + 12 cycle with 55°C/90–96% and 25°C/95–100%	
Environmental conditions (dry heat) acc. to IEC/EN 60068-2-2 Test B	°C/RH	16 hours 55°C/2 hours 70°C with damp heat 55%	
Ambient temperature	°C	– 25 ... +60	
Storage temperature	°C	– 40 ... +70	

Technical data

S800N

S800N		
Installation		
Terminal		Failsafe cage or ringlug terminal
Connections (top/bottom) – C _u only	mm ²	1 ... 50 stranded 1 ... 70 flexible
Tightening torque	Nm	3.5
	in-lbs.	31
Screwdriver		POZI 2
Mounting		EN 60715
Mounting position		any
Supply		any
Dimensions and weight		
Pole dimensions (H x L x W)	mm	82.5 x 95 x 26.5
Pole weight	g	ca. 240

Typical internal resistances and power losses at 25 °C ambient temperature (per pole)

Rated current I _n [A]	Internal resistance R _i [mΩ] B, C, D	Power loss P _v [W] B, C, D
6	51.7	1.8
8	27.2	1.7
10	15.2	1.5
13	12.1	2
16	12.1	3.1
20	8.7	3.5
25	6.8	4.3
32	3.1	3.2
40	2.3	3.7
50	1.7	4.3
63	1.6	6.4
80	1.0	6.4
100	0.8	8
125	0.6	9.4

Maximum permissible earth-fault loop impedance Z_s at U₀ 230V* to ensure compliance with the requirements of IEC 60364-4

The instantaneous release of the MCB ensures an operating time of max. 0.1s (TN system). Determined according to IEC 60364-5-52 / VDE 0100-520 and DIN VDE 0100-520 sheet 2:2002 (source impedance 300mΩ, c = 0.95 and conductor temperature 70 °C = factor 0.8). The internal resistance of the MCB is included.

* U₀: rated voltage against earthed conductor; for U₀: AC 240 V multiply Z_s by 1.04, for U₀: AC 254 V multiply Z_s by 1.10, for U₀: AC 400 V multiply Z_s by 1.74

Rated current [A]	B	C max. Z _s [Ω]	D
6		on request	
8		on request	
10	4.8	2.4	1.5
13	3.7	1.8	1.1
16	3.0	1.5	0.9
20	2.4	1.2	0.7
25	1.9	1.0	0.6
32	1.5	0.7	0.5
40	1.2	0.6	0.4
50	1.0	0.5	0.3
63	0.8	0.4	0.2
80	0.6	0.3	0.2
100	0.5	0.2	0.1
125	0.4	0.2	0.1

Technical data

S800C

		S800C
General Data		
Tripping characteristics		B, C, D, K
Standards		IEC/EN 60947-2, EN 60898-1, UL 1077
Poles		1 ... 4
Rated current I_e	A	10 ... 125
Rated frequency f	Hz	50/60
Rated insulation voltage U_i acc. to IEC/EN 60664-1	V	AC 500
Rated impulse withstand voltage U_{imp} (1.2/50µs)	kV	8
Overvoltage category		IV
Pollution degree		3
Suitability for isolation		yes
Data acc. to IEC/EN 60898-1		
Rated operational voltage U_e	V	AC 230/400
Min. operating voltage	V	AC 12
Rated short-circuit capacity I_{cn}	kA	15kA
Reference temperature for tripping characteristics	°C	30°C (Char. B, C, D)
Electrical and Mechanical Endurance	ops	10 ... 32A: 10000 electrical/10000 mechanical 40 ... 100A: 6000 electrical/10000 mechanical 125A: 4000 electrical/8000 mechanical
Service short-circuit capacity I_{cs}	kA	Char. B, C, D: 230/400V = 7.5 kA
Data acc. to IEC/EN 60947-2		
Rated operational voltage U_e	V	AC 254/440 DC 125 (1-pole) DC 250 (2-pole) DC 375 (3-pole) DC 500 (4-pole)
Min. operating voltage	V	AC 12
Rated ultimate short-circuit capacity I_{cu}	kA	AC 240/415V = 25 kA AC 254/440V = 15 kA DC 125V (1-pole) = 10 kA DC 250V (2-pole) = 10 kA DC 375V (3-pole) = 10 kA DC 500V (4-pole) = 10 kA
Rated service short-circuit capacity I_{cs}	kA	AC 240/415V = 18 kA AC 254/440V = 10 kA DC 125V (1-pole) = 10 kA DC 250V (2-pole) = 10 kA DC 375V (3-pole) = 10 kA DC 500V (4-pole) = 10 kA
Reference temperature for tripping characteristics	°C	B, C, D: 30°C K: 40°C
Electrical and Mechanical Endurance	ops.	6 ... 32A: 10000 electrical/10000 mechanical 40 ... 100A: 6000 electrical/10000 mechanical 125A: 4000 electrical/8000 mechanical
Mechanical Data		
Housing		Material group I, RAL 7035
Toggle		black, lockable
Classification acc. To NF F 126-101, NF F 16-102		I3, F2
Protection degree acc. to EN 60529		IP20; IP40 (actuating end only)
Shock resistance acc. to IEC/EN 60068-2-30		IEC 61373 Cat. 1 Class B, 5g / 30ms acc. To IEC 60068-27 Test Ea
Vibration resistance acc. to IEC/EN 60068-2-6		IEC 60068-2-6 Test Fc; 2-13.2 Hz/1 mm 13.2-100 Hz/0.7 g with load 100% x I_e
Environmental conditions (damp heat) acc. to IEC/EN 60068-2-30	°C/RH	12 + 12 cycle with 55°C/90-96% and 25°C/95-100%
Environmental conditions (dry heat) acc. to IEC/EN 60068-2-2 Test B	°C/RH	16 hours 55°C/2 hours 70°C with damp heat 55%
Ambient temperature	°C	-25 ... +60
Storage temperature	°C	-40 ... +70
Data acc. to UL 1077/ C22.2 No 235, Supplementary Protector		
Alternating current: int. cap.		1 240: 20 (≤ 100A) 277: 10 (≤ 100A) 2,3,4 240: 20 (≤ 100A) 480 Y/277: 10 (≤ 100A)
Direct current: int. cap.		1 125: 10 (≤ 100A) 2, 3, 4 250: 10 (2P, ≤ 100A) 375: 10 (3P, ≤ 100A) 500: 10 (4P, ≤ 100A)

Technical data

S800C

S800C		
Installation		
Terminal		Failsafe cage or ringlug terminal
Connections (top/bottom) – C _u only	mm ²	1 ... 50 stranded 1 ... 70 flexible
	AWG	10 - 30 A: 14 AWG – 2 AWG 40 - 100 A: 14 AWG – 2 AWG
Tightening torque	Nm	3.5
	in-lbs.	31
Screwdriver		POZI 2
Mounting		EN 60715
Mounting position		any
Supply		any
Dimensions and weight		
Pole dimensions (H x L x W)	mm	82.5 x 95 x 26.5
Pole weight	g	ca. 240

Typical internal resistances and power losses at 25°C ambient temperature (per pole)

Rated current I _n [A]	Internal resistance R _i [mΩ] B, C, D, K	Power loss P _i [W] B, C, D, K
10	15.2	1.5
13	12.1	2
16	12.1	3.1
20	8.7	3.5
25	6.8	4.3
32	3.1	3.2
40	2.3	3.7
50	1.7	4.3
63	1.6	6.4
80	1	6.4
100	0.8	8
125	0.6	9.4
100	0.8	8
125	0.6	9.4

Maximum permissible earth-fault loop impedance Z_s at U₀ 230V* to ensure compliance with the requirements of IEC 60364-4

The instantaneous release of the MCB ensures an operating time of max. 0.1s (TN system). Determined according to IEC 60364-5-52 / VDE 0100-520 and DIN VDE 0100-520 sheet 2:2002 (source impedance 300mΩ, c = 0.95 and conductor temperature 70°C = factor 0.8). The internal resistance of the MCB is included.

* U₀: rated voltage against earthed conductor; for U₀: AC 240V multiply Z_s by 1.04, for U₀: AC 254V multiply Z_s by 1.10, for U₀: AC 400V multiply Z_s by 1.74

Rated current I _n [A]	B	C max. Z _s [Ω]	D	K
10	4.8	2.4	1.5	1.5
13	3.7	1.8	1.1	1.1
16	3.0	1.5	0.9	0.9
20	2.4	1.2	0.7	0.7
25	1.9	1.0	0.6	0.6
32	1.5	0.7	0.5	0.5
40	1.2	0.6	0.4	0.4
50	1.0	0.5	0.3	0.3
63	0.8	0.4	0.2	0.2
80	0.6	0.3	0.2	0.2
100	0.5	0.2	0.1	0.1
125	0.4	0.2	0.1	0.1

Technical data

S800B

S800B		
General Data		
Tripping characteristics		B, C, D, K
Standards		IEC/EN 60947-2, EN 60898-1
Poles		1 ... 4
Rated current I_n	A	32 ... 125
Rated frequency f	Hz	50/60
Rated insulation voltage U_i acc. to IEC/EN 60664-1	V	AC 500
Rated impulse withstand voltage U_{imp} (1.2/50µs)	kV	6
Overvoltage category		III
Pollution degree		3
Suitability for isolation		yes
Data acc. to IEC/EN 60898-1		
Rated operational voltage U_e	V	AC 230/400
Min. operating voltage	V	AC 12
Rated short-circuit capacity I_{cn}	kA	AC 230/400 = 10 kA
Reference temperature for tripping characteristics	°C	B, C, D: 30°C
Electrical and Mechanical Endurance	ops.	4000
Service short-circuit capacity I_{cs}	kA	AC 230/400V = 7.5 kA
Data acc. to IEC/EN 60947-2		
Rated operational voltage U_e	V	AC 230/400
Min. operating voltage	V	AC 12
Rated ultimate short-circuit capacity I_{cu}	kA	AC 230/400 V = 16 kA DC 75 V (1-pole) = 10 kA DC 150 V (2-pole) = 10 kA DC 225 V (3-pole) = 10 kA DC 300 V (4-pole) = 10 kA
Rated service short-circuit capacity I_{cs}	kA	10 kA
Reference temperature for tripping characteristics	°C	B, C, D: 30°C K: 40 °C
Electrical and Mechanical Endurance	ops.	32 ... 100A: 1500 electrical/10000 mechanical 125A: 1000 electrical/8000 mechanical
Mechanical Data		
Housing		Material group I, RAL 7035
Toggle		black, lockable
Classification acc. To NF F 126-101, NF F 16-102		I3, F2
Protection degree acc. to EN 60529		IP20; IP40 (actuating end only)
Shock resistance acc. to IEC/EN 60068-2-30		-
Vibration resistance acc. to IEC/EN 60068-2-6		-
Environmental conditions (damp heat) acc. to IEC/EN 60068-2-30	°C/RH	-
Environmental conditions (dry heat) acc. to IEC/EN 60068-2-2 Test B	°C/RH	-
Ambient temperature	°C	-25 ... +60
Storage temperature	°C	-40 ... +70
Installation		
Terminal		Failsafe cage or ringlug terminal
Connections (top/bottom) – C_u only	mm ²	1 ... 50 stranded 1 ... 70 flexible
Tightening torque	Nm in-lbs.	3.5 31
Screwdriver		POZI 2
Mounting		EN 60715
Mounting position		any
Supply		any
Dimensions and weight		
Pole dimensions (H x L x W)	mm	82.5 x 95 x 26.5
Pole weight	g	ca. 240

Typical internal resistances and power losses at 25°C ambient temperature (per pole)

Rated current I_n [A]	Internal resistance R_i [mΩ]		Power loss P_v [W]	
	B, C	D, K	B, C	D, K
32	3.1	3.1	3.2	3.2
40	2.3	2.3	3.7	3.7
50	1.7	1.7	4.3	4.3
63	1.6	1.6	6.4	6.4
80	1.0	1.0	6.4	6.4
100	0.8	0.8	8.0	8.0
125	0.7	-	10.9	-

Technical data

S800HV

S800HV		
General Data		
Tripping characteristics		C, K
Standards		IEC/EN 60947-2, UL 1077
Poles		1 ... 3
Rated frequency f	Hz	50/60
Overvoltage category		III
Pollution degree		2
Suitability for isolation		yes
Data acc. to IEC/EN 60947-2		
Rated operational voltage U_e	V	AC 580/1000
Min. operating voltage	V	AC 12
Rated operational current I_n	A	0.5 ... 125
Rated ultimate short-circuit capacity I_{cu}	kA	1.5 (0.5...5 A) 4 (6 ... 63 A) 3 (80 ... 125 A)
Rated service short-circuit capacity I_{cs}	kA	1.5 (0.5 ... 5 A) 2.5 (6 ... 63 A) 2 (80 ... 125 A)
Reference temperature for tripping characteristics	°C	K: 40 C: 30
Electrical and Mechanical Endurance	ops.	0.5 ... 100 A: 1500 electrical/10000 mechanical 125 A: 1000 electrical/8000 mechanical
Data according to UL 1077/ C22.2 No 235, Supplementary Protector		
Alternating current		600 V/347: 15 (3P, 10...32A)*
Mechanical Data		
Housing		Material group I, RAL 7035
Toggle		black, lockable
Protection degree acc. to EN 60529		IP20; IP40 (actuating end only)
Classification acc. To NF F 126-101, NF F 16-102		I3, F2
Classification acc. to IEC 61373 (shock and vibration)		Cat. 1, Class B
Shock resistance acc. to IEC/EN 60068-2-27		Test Ea: 5g / 30ms
Vibration resistance acc. to IEC/EN 60068-2-6		Test Fc: 2-13.2Hz/1mm 13.2-100Hz/0.7g with load 100% x I_e
Environmental conditions (damp heat) acc. to IEC/EN 60068-2-30	°C/RH	12 + 12 cycle with 55°C/90-96% and 25°C/95-100%
Environmental conditions (dry heat) acc. to IEC/EN 60068-2-2 Test B	°C/RH	16 hours 55°C / 2 hours 70°C / 55% RH
Ambient temperature	°C	-25 ... +60
Storage temperature	°C	-40 ... +70
Installation		
Terminal		Failsafe cage terminal
Connections (top/bottom) – C_u only	mm ²	1 ... 50 stranded 1 ... 70 flexible
Tightening torque	Nm	3.5
Screwdriver		POZI 2
Mounting		EN 60715
Mounting position		any
Supply		any
Dimensions and weight		
Pole dimensions (H x L x W)	mm	142 x 82.5 x 26.5
Pole weight	kg	0.27

* 3P, 10 ... 32 A - only valid with XT2L 125 TMF 35-400

Technical data

S800HV

S800HV					
Altitude					
Altitude	[m]	2000	3000	4000	5000
Rated impulse withstand voltage U_{imp}	[kV]	8	8	8	8
Rated operational voltage U_e	[V]	1000	870	780	690
Max. rated current I_n	[A]	$1 \times I_n$	$0.96 \times I_n$	$0.93 \times I_n$	$0.9 \times I_n$

* 3P, 10 ... 32 A - only valid with XT2L 125 TMF 35-400

Typical internal resistances and power losses at 25 °C ambient temperature (per pole)

Rated current I_n [A]	Internal resistance R_i [mΩ] C, K	Power loss P_v [W] C, K
0.5	8124.6	2
1	1627.2	1.6
1.6	1118.6	2.9
2	556.6	2.2
2.5	399.3	2.5
3	270.3	2.4
4	126.4	2
5	57.9	1.5
6	51.7	1.8
8	27.2	1.7
10	15.2	1.5
13	12.1	2
16	12.1	3.1
20	8.7	3.5
25	6.8	4.3
32	3.1	3.2
40	2.3	3.7
50	1.7	4.3
63	1.6	6.4
80	1	6.4
100	0.8	8
125	0.6	9.4

Technical data

S800U

S800U		
General Data		
Tripping characteristics		K, Z
Standards		UL489
Poles		1 ... 4
Rated current I_e	A	10...100
Rated frequency f	Hz	50/60
Rated insulation voltage U_i acc. to IEC/EN 60664-1	V	AC 690
Rated impulse withstand voltage $U_{imp.}$ (1.2/50µs)	kV	8
Overvoltage category		IV
Pollution degree		3
Suitability for isolation		yes
Data acc. to IEC/EN 60947-2		
Rated operational voltage U_e	V	AC 240/415
Min. operating voltage	V	AC 12
Rated ultimate short-circuit capacity I_{cu}	kA	AC 240V (1-pole) = 30kA AC 415V (multipole) = 50kA
Rated service short-circuit capacity I_{cs}	kA	AC 240V (1-pole) = 25kA AC 415V (multipole) = 40kA
Reference temperature for tripping characteristics	°C	25 °C
Electrical and Mechanical Endurance	ops.	10 ... 32A: 10 000 electrical/10 000 mechanical 40 ... 100A: 6000 electrical/10000 mechanical
Data acc. to UL / CSA		
Rated voltage	V	AC 240
Rated interrupting capacity acc. to UL 1077	kA	
Short-circuit current rating acc. to UL 489	kA	AC 240V (1-pole) = 30kA AC 240V (multipole) = 50kA
Short-circuit current rating acc. to UL 489B	kA	
Reference temperature for tripping characteristics		25 °C
Electrical and Mechanical endurance	ops.	acc. to UL489 6000 electrical; 4000 mechanical
Mechanical Data		
Protection degree acc. to EN 60529		IP20; IP40 (actuating end only)
Shock resistance acc. to IEC/EN 60068-2-30		IEC 61373 Cat. 1 Class B, 5g/30ms acc. To IEC 60068-27 Test Ea
Vibration resistance acc. to IEC/EN 60068-2-6		IEC 60068-2-6 Test Fc; 2 - 13.2 Hz/1 mm 13.2 - 100Hz/0.7 g with load 100% x I_e
Environmental conditions (damp heat) acc. to IEC/EN 60068-2-30	°C/RH	12 + 12 cycle with 55°C/90 - 96% and 25°C/95 - 100%
Environmental conditions (dry heat) acc. to IEC/EN 60068-2-2 Test B	°C/RH	16 hours 55 °C/2 hours 70 °C with damp heat 55 %
Ambient temperature	°C	-25 ... +60
Storage temperature	°C	-40 ... +70
Installation		
Terminal		Failsafe cage or ringlug terminal
Connections (top/bottom) – C_u only	mm ²	1 ... 50 stranded 1 ... 70 flexible
	AWG	10 - 30A: 14 - 2 AWG 40 - 100A: 1 - 8 AWG
Tightening torque	Nm	3.5
	in-lbs.	31
Screwdriver		POZI 2
Mounting		any
Mounting position		any
Supply		any
Dimensions and weight		
Pole dimensions (H x L x W)	mm	95 x 26.5 x 82.5
Pole weight	g	240

Technical data

S800U

Typical internal resistances
and power losses at 25°C
ambient temperature (per pole)

Rated current I_n [A]	Internal resistance R_i [mΩ] K, Z	Power loss P_v [W] K, Z
10	15.2	1.5
15	12.1	2.7
20	8.7	3.5
25	6.8	4.2
30	3.1	2.8
40	2.3	3.7
50	1.7	4.3
60	1.6	5.8
70	1.0	4.9
80	1.0	6.4
90	0.8	6.5
100	0.8	8.3

FONLEE
豐立自動控制器材有限公司
WWW.FONLEE.COM.TW

Technical data

S804U-UCZ

S804U-UCZ		
General Data		
Tripping characteristics		UCZ
Standards		UL489
Poles		4
Rated current I_e	A	10 - 80
Rated frequency f	Hz	-
Rated insulation voltage U_i acc. to IEC/EN 60664-1	V	DC 1500
Rated impulse withstand voltage $U_{imp.}$ (1.2/50µs)	kV	8
Overtoltage category		IV
Pollution degree		3
Suitability for isolation		yes
Data acc. to IEC/EN 60947-2		
Rated operational voltage U_e	V	-
Min. operating voltage	V	-
Rated ultimate short-circuit capacity I_{cu}	kA	-
Rated service short-circuit capacity I_{cs}	kA	-
Reference temperature for tripping characteristics	°C	-
Electrical and Mechanical Endurance	ops.	-
Data acc. to UL / CSA		
Rated voltage	V	DC 600
Rated interrupting capacity acc. to UL 1077	kA	-
Short-circuit current rating acc. to UL 489	kA	10
Short-circuit current rating acc. to UL 489B	kA	-
Reference temperature for tripping characteristics		25 °C
Electrical and Mechanical endurance	ops.	acc. to UL489 6000 electrical; 4000 mechanical
Mechanical Data		
Protection degree acc. to EN 60529		IP20; IP40 (actuating end only)
Shock resistance acc. to IEC/EN 60068-2-30		-
Vibration resistance acc. to IEC/EN 60068-2-6		-
Environmental conditions (damp heat) acc. to IEC/EN 60068-2-30	°C/RH	-
Environmental conditions (dry heat) acc. to IEC/EN 60068-2-2 Test B	°C/RH	-
Ambient temperature	°C	- 25 ... +60
Storage temperature	°C	- 40 ... +70
Installation		
Terminal		Failsafe cage terminal
Connections C_u (top/bottom)	AWG	10 - 32A: 14-2 AWG 40 - 80A: 1-8 AWG
Tightening torque	Nm	3.5
	in-lbs.	31
Screwdriver		POZI 2
Mounting		any
Mounting position		any
Supply		any
Dimensions and weight		
Pole dimensions (H x L x W)	mm	142 x 26.5 x 82.5
Pole weight	g	240

Technical data

S804U-PVS

S804U-PVS		
General Data		
Tripping characteristics		PVS
Standards		UL489B (Photovoltaic)
Poles		4
Rated current I_e	A	5
Rated frequency f	Hz	-
Rated insulation voltage U_i acc. to IEC/EN 60664-1	V	DC 1500
Rated impulse withstand voltage $U_{imp.}$ (1.2/50 μ s)	kV	8
Overvoltage category		IV
Pollution degree		3
Suitability for isolation		yes
Data acc. to IEC/EN 60947-2		
Rated operational voltage U_e	V	-
Min. operating voltage	V	-
Rated ultimate short-circuit capacity I_{cu}	kA	-
Rated service short-circuit capacity I_{cs}	kA	-
Reference temperature for tripping characteristics	$^{\circ}$ C	-
Electrical and Mechanical Endurance	ops.	-
Data acc. to UL / CSA		
Rated voltage	V	DC 1000
Rated interrupting capacity acc. to UL 1077	kA	-
Short-circuit current rating acc. to UL 489	kA	-
Short-circuit current rating acc. to UL 489B	kA	3 kA
Reference temperature for tripping characteristics		50 $^{\circ}$ C
Electrical and Mechanical endurance	ops.	acc. to UL489 1000 electrical; 1000 mechanical
Mechanical Data		
Protection degree acc. to EN 60529		IP20; IP40 (actuating end only)
Shock resistance acc. to IEC/EN 60068-2-30		-
Vibration resistance acc. to IEC/EN 60068-2-6		-
Environmental conditions (damp heat) acc. to IEC/EN 60068-2-30	$^{\circ}$ C/RH	-
Environmental conditions (dry heat) acc. to IEC/EN 60068-2-2 Test B	$^{\circ}$ C/RH	-
Ambient temperature	$^{\circ}$ C	-25 ... +60
Storage temperature	$^{\circ}$ C	-40 ... +70
Installation		
Terminal		Failsafe cage terminal
Connections (top/bottom) – C_u only	mm ²	1 ... 50 stranded 1 ... 70 flexible
	AWG	14 AWG - 2 AWG Single conductor per terminal, 75C wire
Flexible Cross-section of conductors (top/bottom)	mm ²	-
	AWG	14 AWG - 2 AWG Single conductor per terminal - copper only, 75C wire
Tightening torque	Nm	3.5
	in-lbs.	31
Screwdriver		POZI 2
Mounting		any
Mounting position		any
Supply		any
Dimensions and weight		
Pole dimensions (H x L x W)	mm	142 x 26.5 x 82.5
Pole weight	g	240

Technical data

S800PV-SP

S800PV-SP		
General Data		
Tripping characteristics		SP
Standards		IEC / EN 60947-2 and Annex P
Poles		2 ... 4
Rated frequency I_e	A	5 ... 125
Rated frequency f	Hz	-
Rated insulation voltage U_i acc. to IEC/EN 60664-1	V	DC 1500
Rated impulse withstand voltage $U_{imp.}$ (1.2/50 μ s)	kV	8
Overtoltage category		III
Pollution degree		2
Suitability for isolation		yes
Data acc. to IEC/EN 60947-2		
Rated operational voltage U_e	V	2-pole DC 800V: 5 ... 125 A 3-pole DC 1200V: 5 ... 125 A 4-pole DC 1500V: 5 ... 125 A
Min. operating voltage	V	-
Rated ultimate short-circuit capacity I_{cu}	kA	5 ... 16 A acc. IEC 60947-2 Annex P. $I_{cu} = 5$ kA 20 ... 125 A, acc. IEC 60947-2, $I_{cu} = 5$ kA 20 ... 125 A, acc. IEC 60947-2 Annex P. $I_{cu} = 3$ kA
Rated service short-circuit capacity I_{cs}	kA	$I_{cu} = I_{cs}$
Reference temperature for tripping characteristics	°C	40 °C
Electrical and Mechanical Endurance	ops.	acc. to Annex P: 5 ... 16 A: 300 electrical;9700 mechanical acc. to IEC 60947-2 (general part): 20 ... 100 A: 1500 electrical;8500 mechanical 125 A: 1000 electrical;9000 mechanical
Mechanical Data		
Housing		Material group I, RAL 7035
Toggle		black, lockable
Classification acc. To NF F 126-101, NF F 16-102		-
Protection degree acc. to EN 60529		IP20; IP40 (actuating end only)
Shock resistance acc. to IEC/EN 60068-2-30		IEC 61373 Cat. 1 Class B, 5g / 30ms acc. To IEC 60068-27 Test Ea
Vibration resistance acc. to IEC/EN 60068-2-6		IEC 60068-2-6 Test Fc; 2 - 13.2Hz/1 mm 13.2 - 100Hz/0.7g with load 100% x I_e
Environmental conditions (damp heat) acc. to IEC/EN 60068-2-30	°C/RH	12 + 12 cycle with 55 °C/90 - 96% and 25 °C/95 - 100%
Environmental conditions (dry heat) acc. to IEC/EN 60068-2-2 Test B	°C/RH	16 hours 55 °C/2 hours 70 °C with damp heat 55 %
Ambient temperature	°C	-25 ... +60
Storage temperature	°C	-40 ... +70
Installation		
Terminal		Failsafe cage or ringlug terminal
Connections (top/bottom) - C_u only	mm ²	1 ... 50 stranded 1 ... 70 flexible
Tightening torque	Nm in-lbs.	3.5 31
Screwdriver		POZI 2
Mounting		any
Mounting position		any
Supply		any
Dimensions and weight		
Pole dimensions (H x L x W)	mm	95 x 26.5 x 82.5
Pole weight	g	240

Technical data

S802PV-M-H and S804PV-SD

		S802PV-M-H	S800PV-SD
General Data			
Tripping characteristics		none	none
Standards		IEC / EN 60947-3	IEC / EN 60947-3 and Annex D
Poles		2 (polarized)	2 ... 4
Rated current I_e	A	32, 63, 100	32, 63, 125
Rated insulation voltage U_i acc. to IEC/EN 60664-1	V	DC 1500	DC 1500
Rated impulse withstand voltage $U_{imp.}$ (1.2/50µs)	kV	8	8
Overtoltage category		III	III
Pollution degree		2	2
Suitability for isolation		yes	yes
Data acc. to IEC/EN 60947-3			
Rated operational voltage U_e	V	DC 1000V: 2-pole	DC 800V: 2-pole DC 1200V: 3-Pole DC 1500V: 4-pole
Min. operating voltage	V	-	-
Rated short-term withstand current I_{cw}	kA	1.5	1.5
Rated short-circuit making capacity I_{cm}	kA	0.5	0.5
Utilisation category		DC-21 A	DC-21 A, DC-PV2
Electrical and Mechanical Endurance	ops.	1500 electrical/10000 mechanical	32, 63A: 1500 electrical/10000 mechanical 125A: 1000 electrical/8000 mechanical
Mechanical Data			
Housing		Material group I, RAL 7035	Material group I, RAL 7035
Toggle		black, lockable	black, lockable
Classification acc. To NF F 126-101, NF F 16-102		-	-
Protection degree acc. to EN 60529		IP20; IP40 (actuating end only)	IP20; IP40 (actuating end only)
Shock resistance acc. to IEC/EN 60068-2-30		IEC 61373 Cat. 1 Class B, 5g / 30ms acc. To IEC 60068-27 Test Ea	IEC 61373 Cat. 1 Class B, 5g / 30ms acc. To IEC 60068-27 Test Ea
Vibration resistance acc. to IEC/EN 60068-2-6		IEC 60068-2-6 Test Fc; 2 - 13.2 Hz/1 mm 13.2 - 100 Hz/0.7 g with load 100% x I_e	IEC 60068-2-6 Test Fc; 2 - 13.2 Hz/1 mm 13.2 - 100 Hz/0.7 g with load 100% x I_e
Environmental conditions (damp heat) acc. to IEC/EN 60068-2-30	°C/RH	12 + 12 cycle with 55°C/90 - 96% and 25°C/95 - 100%	12 + 12 cycle with 55°C/90 - 96% and 25°C/95 - 100%
Environmental conditions (dry heat) acc. to IEC/EN 60068-2-2 Test B	°C/RH	16 hours 55°C/2 hours 70°C with damp heat 55%	16 hours 55°C/2 hours 70°C with damp heat 55%
Ambient temperature	°C	-25 ... +60	-25 ... +60
Storage temperature	°C	-40 ... +70	-40 ... +70
Installation			
Terminal		Failsafe cage or ringlug terminal	Failsafe cage or ringlug terminal
Connections (top/bottom) - C_u only	mm ²	1 ... 50 stranded 1 ... 70 flexible	1 ... 50 stranded 1 ... 70 flexible
Tightening torque	Nm	3.5	3.5
	in-lbs.	31	31
Screwdriver		POZI 2	POZI 2
Mounting		any	any
Mounting position		any	any
Supply		any (taking into account the polarization)	any (taking into account the polarization)
Dimensions and weight			
Pole dimensions (H x L x W)	mm	95 x 26.5 x 82.5	95 x 26.5 x 82.5
Pole weight	g	240	240

Technical data

S800PV

Typical internal resistances
and power losses at 25°C
ambient temperature (per pole)

Rated current I_n [A]	Internal resistance R_i [mΩ]		Power loss P_v [W]	
	PV-SP	PV-SD	PV-SP	PV-SD
10	15.2		1.5	
13	12.1		2.0	
16	12.1		3.1	
20	8.7		3.5	
25	6.8		4.3	
32	3.1	1.8	3.2	1.8
40	2.3		3.7	
50	1.7		4.3	
63	1.6	0.9	6.4	3.6
80	1.0		6.4	
100	0.8		8.0	
125	0.6	0.5	9.4	7.8

For the effects of temperatures not given in the above table, please get in touch with your ABB contact.

FONLEE
豐立自動控制器材有限公司
WWW.FONLEE.COM.TW

Technical data

Performance at different ambient temperatures

Derating of load capability of S800

The table refers to the product standard IEC 60947-2. These values are only valid if the mounting conditions are similar to the IEC 60947-2. The rated value of the current of the S800 refers to a calibration temperature of 30°C for characteristics B, C and D.

For characteristics K, UCK and PV-SP it refers to 40°C and the UL-version (S800U) refers to a calibration temperature of 25°C. Max. operating current depending on the ambient temperature of S800 with characteristic B, C, D, UCB.

B, C, D, UCB	Ambient temperature (°C)																				
	I_n [A]	-25	-20	-15	-10	-5	0	5	10	15	20	25	30	35	40	45	50	55	60	65	70
0.5	0.6	0.6	0.6	0.6	0.6	0.5	0.5	0.5	0.5	0.5	0.5	0.5	0.5	0.5	0.5	0.5	0.5	0.4	0.4	0.4	0.4
1	1.2	1.2	1.2	1.1	1.1	1.1	1.1	1.1	1.0	1.0	1.0	1.0	1.0	1.0	0.9	0.9	0.9	0.9	0.9	0.9	0.8
1.6	1.9	1.9	1.8	1.8	1.8	1.8	1.7	1.7	1.7	1.7	1.6	1.6	1.6	1.5	1.5	1.5	1.4	1.4	1.4	1.4	1.3
2	2.4	2.3	2.3	2.3	2.2	2.2	2.2	2.1	2.1	2.1	2.0	2.0	2.0	1.9	1.9	1.8	1.8	1.8	1.7	1.7	1.7
2.5	3.0	2.9	2.9	2.8	2.8	2.7	2.7	2.7	2.6	2.6	2.5	2.5	2.5	2.4	2.4	2.3	2.3	2.2	2.2	2.1	2.1
3	3.6	3.5	3.5	3.4	3.4	3.3	3.2	3.2	3.1	3.1	3.0	3.0	2.9	2.9	2.8	2.8	2.7	2.7	2.6	2.6	2.5
4	4.8	4.7	4.6	4.5	4.5	4.4	4.3	4.3	4.2	4.1	4.1	4.0	3.9	3.8	3.8	3.7	3.6	3.5	3.5	3.4	3.3
5	6.0	5.9	5.8	5.7	5.6	5.5	5.4	5.3	5.2	5.2	5.1	5.0	4.9	4.8	4.7	4.6	4.5	4.4	4.3	4.3	4.2
6	7.2	7.1	7.0	6.9	6.8	6.7	6.6	6.4	6.3	6.2	6.1	6.0	5.9	5.8	5.7	5.6	5.4	5.3	5.2	5.1	5.0
8	9.6	9.5	9.3	9.2	9.0	8.9	8.7	8.6	8.4	8.3	8.1	8.0	7.9	7.7	7.6	7.4	7.3	7.1	7.0	6.8	6.7
10	12.0	11.8	11.7	11.5	11.3	11.1	10.9	10.7	10.6	10.4	10.2	10.0	9.8	9.6	9.4	9.3	9.1	8.9	8.7	8.5	8.3
13	15.6	15.4	15.1	14.9	14.7	14.4	14.2	14.0	13.7	13.5	13.2	13.0	12.8	12.5	12.3	12.0	11.8	11.6	11.3	11.1	10.9
16	19.2	18.9	18.6	18.3	18.1	17.8	17.5	17.2	16.9	16.6	16.3	16.0	15.7	15.4	15.1	14.8	14.5	14.2	13.9	13.7	13.4
20	24.0	23.7	23.3	22.9	22.6	22.2	21.8	21.5	21.1	20.7	20.4	20.0	19.6	19.3	18.9	18.5	18.2	17.8	17.4	17.1	16.7
25	30.0	29.6	29.1	28.7	28.2	27.8	27.3	26.8	26.4	25.9	25.5	25.0	24.5	24.1	23.6	23.2	22.7	22.2	21.8	21.3	20.9
32	38.5	37.9	37.3	36.7	36.1	35.5	34.9	34.3	33.8	33.2	32.6	32.0	31.4	30.8	30.2	29.7	29.1	28.5	27.9	27.3	26.7
40	48.1	47.3	46.6	45.9	45.1	44.4	43.7	42.9	42.2	41.5	40.7	40.0	39.3	38.5	37.8	37.1	36.3	35.6	34.9	34.1	33.4
50	60.1	59.2	58.3	57.3	56.4	55.5	54.6	53.7	52.8	51.8	50.9	50.0	49.1	48.2	47.2	46.3	45.4	44.5	43.6	42.7	41.7
63	75.7	74.6	73.4	72.2	71.1	69.9	68.8	67.6	66.5	65.3	64.2	63.0	61.8	60.7	59.5	58.4	57.2	56.1	54.9	53.8	52.6
80	96.1	94.7	93.2	91.7	90.3	88.8	87.3	85.9	84.4	82.9	81.5	80.0	78.5	77.1	75.6	74.1	72.7	71.2	69.7	68.3	66.8
100	120.2	118.4	116.5	114.7	112.8	111.0	109.2	107.3	105.5	103.7	101.8	100.0	98.2	96.3	94.5	92.7	90.8	89.0	87.2	85.3	83.5
125	150.2	147.9	145.6	143.4	141.1	138.8	136.5	134.2	131.9	129.6	127.3	125.0	122.7	120.4	118.1	115.8	113.5	111.2	108.9	106.7	104.4

Max. operating current depending on the ambient temperature of S800 with characteristic K, UCK and PV-SP

PV-SP, K, UCK	Ambient temperature [°C]																				
	I_n [A]	-25	-20	-15	-10	-5	0	5	10	15	20	25	30	35	40	45	50	55	60	65	70
0.5	0.6	0.6	0.6	0.6	0.6	0.6	0.6	0.5	0.5	0.5	0.5	0.5	0.5	0.5	0.5	0.5	0.5	0.5	0.5	0.4	0.4
1	1.2	1.2	1.2	1.2	1.2	1.1	1.1	1.1	1.1	1.1	1.0	1.0	1.0	1.0	1.0	0.9	0.9	0.9	0.9	0.9	0.9
1.6	2.0	1.9	1.9	1.9	1.8	1.8	1.8	1.8	1.7	1.7	1.7	1.6	1.6	1.6	1.5	1.5	1.5	1.4	1.4	1.4	1.4
2	2.5	2.4	2.4	2.3	2.3	2.3	2.2	2.2	2.2	2.1	2.1	2.1	2.0	2.0	1.9	1.9	1.8	1.8	1.8	1.8	1.7
2.5	3.1	3.0	3.0	2.9	2.9	2.8	2.8	2.7	2.7	2.7	2.6	2.6	2.5	2.5	2.5	2.4	2.4	2.3	2.3	2.2	2.2
3	3.7	3.6	3.6	3.5	3.5	3.4	3.4	3.3	3.2	3.2	3.1	3.1	3.0	3.0	2.9	2.9	2.8	2.8	2.7	2.7	2.6
4	4.9	4.8	4.8	4.7	4.6	4.5	4.5	4.4	4.3	4.3	4.2	4.1	4.1	4.0	3.9	3.8	3.8	3.7	3.6	3.5	3.5
5	6.1	6.0	6.0	5.9	5.8	5.7	5.6	5.5	5.4	5.3	5.2	5.2	5.1	5.0	4.9	4.8	4.7	4.6	4.5	4.4	4.3
6	7.43	7.32	7.21	7.10	6.99	6.88	6.77	6.66	6.55	6.44	6.33	6.22	6.11	6.00	5.89	5.78	5.67	5.56	5.45	5.34	5.23
8	9.91	9.76	9.61	9.47	9.32	9.17	9.03	8.88	8.73	8.59	8.44	8.29	8.15	8.00	7.85	7.71	7.56	7.41	7.27	7.12	6.97
10	12.4	12.2	12.0	11.8	11.7	11.5	11.3	11.1	10.9	10.7	10.6	10.4	10.2	10.0	9.8	9.6	9.4	9.3	9.1	8.9	8.7
13	16.1	15.9	15.6	15.4	15.1	14.9	14.7	14.4	14.2	14.0	13.7	13.5	13.2	13.0	12.8	12.5	12.3	12.0	11.8	11.6	11.3
16	19.8	19.5	19.2	18.9	18.6	18.3	18.1	17.8	17.5	17.2	16.9	16.6	16.3	16.0	15.7	15.4	15.1	14.8	14.5	14.2	13.9
20	24.8	24.4	24.0	23.7	23.3	22.9	22.6	22.2	21.8	21.5	21.1	20.7	20.4	20.0	19.6	19.3	18.9	18.5	18.2	17.8	17.4
25	31.0	30.5	30.0	29.6	29.1	28.7	28.2	27.8	27.3	26.8	26.4	25.9	25.5	25.0	24.5	24.1	23.6	23.2	22.7	22.2	21.8
32	39.6	39.0	38.5	37.9	37.3	36.7	36.1	35.5	34.9	34.3	33.8	33.2	32.6	32.0	31.4	30.8	30.2	29.7	29.1	28.5	27.9
40	49.5	48.8	48.1	47.3	46.6	45.9	45.1	44.4	43.7	42.9	42.2	41.5	40.7	40.0	39.3	38.5	37.8	37.1	36.3	35.6	34.9
50	61.9	61.0	60.1	59.2	58.3	57.3	56.4	55.5	54.6	53.7	52.8	51.8	50.9	50.0	49.1	48.2	47.2	46.3	45.4	44.5	43.6
63	78.0	76.9	75.7	74.6	73.4	72.2	71.1	69.9	68.8	67.6	66.5	65.3	64.2	63.0	61.8	60.7	59.5	58.4	57.2	56.1	54.9
80	99.1	97.6	96.1	94.7	93.2	91.7	90.3	88.8	87.3	85.9	84.4	82.9	81.5	80.0	78.5	77.1	75.6	74.1	72.7	71.2	69.7
100	123.9	122.0	120.2	118.4	116.5	114.7	112.8	111.0	109.2	107.3	105.5	103.7	101.8	100.0	98.2	96.3	94.5	92.7	90.8	89.0	87.2
125	154.8	152.5	150.2	147.9	145.6	143.4	141.1	138.8	136.5	134.2	131.9	129.6	127.3	125.0	122.7	120.4	118.1	115.8	113.5	111.2	108.9

Technical data

Performance at different ambient temperatures

Max. operating current depending on the ambient temperature of S800U-K, -Z, -UCZ

U-K, Z, UCZ	Ambient temperature [°C]																				
I_n [A]	-25	-20	-15	-10	-5	0	5	10	15	20	25	30	35	40	45	50	55	60	65	70	75
10	11.8	11.7	11.5	11.3	11.1	10.9	10.7	10.6	10.4	10.2	10.0	9.8	9.6	9.4	9.3	9.1	8.9	8.7	8.5	8.3	8.2
13	15.4	15.1	14.9	14.7	14.4	14.2	14.0	13.7	13.5	13.2	13.0	12.8	12.5	12.3	12.0	11.8	11.6	11.3	11.1	10.9	10.6
16	18.9	18.6	18.3	18.1	17.8	17.5	17.2	16.9	16.6	16.3	16.0	15.7	15.4	15.1	14.8	14.5	14.2	13.9	13.7	13.4	13.1
20	23.7	23.3	22.9	22.6	22.2	21.8	21.5	21.1	20.7	20.4	20.0	19.6	19.3	18.9	18.5	18.2	17.8	17.4	17.1	16.7	16.3
25	29.6	29.1	28.7	28.2	27.8	27.3	26.8	26.4	25.9	25.5	25.0	24.5	24.1	23.6	23.2	22.7	22.2	21.8	21.3	20.9	20.4
30	37.9	37.3	36.7	36.1	35.5	34.9	34.3	33.8	33.2	32.6	32.0	31.4	30.8	30.2	29.7	29.1	28.5	27.9	27.3	26.7	26.1
40	47.3	46.6	45.9	45.1	44.4	43.7	42.9	42.2	41.5	40.7	40.0	39.3	38.5	37.8	37.1	36.3	35.6	34.9	34.1	33.4	32.7
50	59.2	58.3	57.3	56.4	55.5	54.6	53.7	52.8	51.8	50.9	50.0	49.1	48.2	47.2	46.3	45.4	44.5	43.6	42.7	41.7	40.8
63	74.6	73.4	72.2	71.1	69.9	68.8	67.6	66.5	65.3	64.2	63.0	61.8	60.7	59.5	58.4	57.2	56.1	54.9	53.8	52.6	51.4
80	94.7	93.2	91.7	90.3	88.8	87.3	85.9	84.4	82.9	81.5	80.0	78.5	77.1	75.6	74.1	72.7	71.2	69.7	68.3	66.8	65.3
100	118.4	116.5	114.7	112.8	111.0	109.2	107.3	105.5	103.7	101.8	100.0	98.2	96.3	94.5	92.7	90.8	89.0	87.2	85.3	83.5	81.7

Max. operating current depending on the ambient temperature of S804U - PVSP5, - PVS5

- PVSP5, - PVS5	Ambient temperature [°C]																			
I_n [A]	-25	-20	-15	-10	-5	0	5	10	15	20	25	30	35	40	45	50	55	60	65	70
5	6.5	6.4	6.3	6.2	6.1	6.0	5.9	5.8	5.7	5.6	5.5	5.4	5.3	5.2	5.1	5.0	4.9	4.8	4.7	4.6

Influence of mounting distances between the devices

Multiply the rated current referring to your max. occurent temperature with the factor of "influence of mounting distances"

Example: 2xS802B-B125 at T= 40 °C with 5 mm distance

$$I_n = 120.4A \times 92.1\% = 110.9A$$

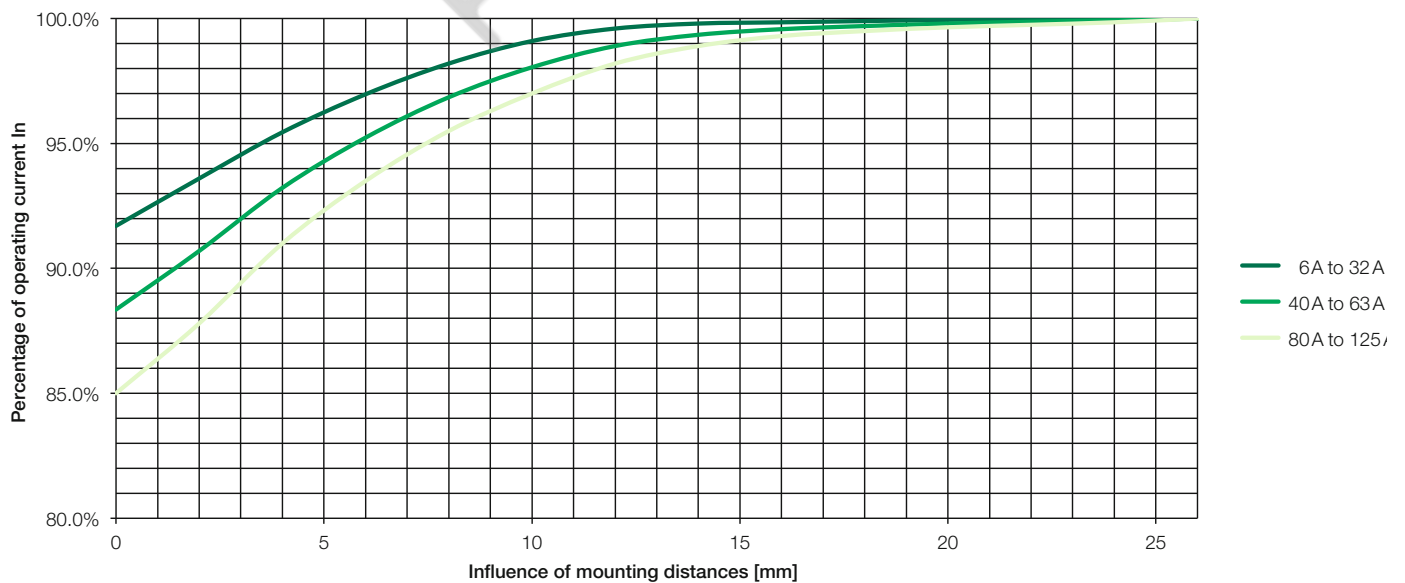

Further influencing factors, which can lead to a reduction of the maximum operating current, are:

- Shortening the cable length compared to IEC 60947-1/-2
- Reducing the cable cross section compared to IEC 60947-1/-2
- Accumulation of cables

Technical data

Accessories

Auxiliary contact S800-AUX

Utilisation categories compliant to IEC 60947-5-1		AC15 400/2A AC15 240/6A DC13 250/0.55A DC13 125V/1.1A DC13 60V/2A DC13 24V/4A
Rated values compliant to UL 489		125 VAC/6A 250 VAC/5A 24 VDC/4A 125 VDC/0.3A 250 VDC/0.15A
Conventional free air thermal current I_{th}	A	6
Minimum operational current I_{min}	mA	3
Minimum operational voltage U_{min}	V	24
Rated insulation voltage U_i	V	690
Number of contacts		2
Rated impulse withstand voltage U_{imp}	kV	6
Pollution degree		3
Standard		IEC 60947-5-1 / UL 489
Contact function		Changeover contact
Connection C_u	mm ²	1 x 2.5 2 x 1.5 14 AWG
Tightening torque	Nm	1
AC/DC feed		any
Mounting on DIN top hat rail		EN 60715
Protection category		IP20
Permissible operating ambient temperature	°C	-25 ... +60
Storage temperature	°C	-40 ... +70
Mech. lifetime of device		6000 switching cycles
I_{cu}	A	1000
Vibration resistance		IEC 60068-2-6; EN 61373 Cat.1/Class B 5g, 20 frequency cycle 5 ... 150 ... 5 Hz at 24 V AC/DC, 5 mA short-term interruption <10 ms

Technical data

Accessories

Combined auxiliary and signal contact S800-AUX/ALT		
Utilisation categories compliant to IEC 60947-5-1		AC15 400/2A AC15 240/6A DC13 250/0.55A DC13 125V/1.1A DC13 60V/2A DC13 24V/4A
Rated values compliant to UL 489		125 VAC/6A 250 VAC/5A 24 VDC/4A 125 VDC/0.3A 250 VDC/0.15A
Conventional free air thermal current I_{th}	A	6
Minimum operational I_{min}	mA	3
Minimum operational voltage U_{min}	V	24
Rated insulation voltage U_i	A	690
Number of contacts		2 (1x AUX, 1x AUX/ALT)
Rated impulse withstand voltage U_{imp}	kV	6
Pollution degree		3
Standard		IEC 60947-5-1 / UL 489
Contact function		Changeover contact
Connection C_u	mm ²	1 x 2.5 2 x 1.5 14 AWG
Tightening torque	Nm	1
AC/DC feed.		any
Mounting on DIN top hat rail		EN 60715
Protection category		IP20
Permissible operating ambient temperature	°C	-25 ... +60
Storage temperature	°C	-40 ... +70
Mech. lifetime of device		6000 switching cycles
I_{cu} with S450E	A	1000
Vibration resistance		IEC 60068-2-6; EN 61373 Cat.1/Class B 5g, 20 frequency cycle 5 ... 150 ... 5 Hz at 24V AC/DC, 5mA short-term interruption <10ms
S800-RSU-H IEC version		
S800W-RSU World version		
Remote Switching Units for High Performance MCB		
Operating Voltage		24 VDC
Current Consumption I_{rms}	A	2.5
Stand-by Current	mA	< 50
Switching Time OFF-ON	ms	< 500
Switching Time ON-OFF	ms	< 250
Ambient Operation Temperature	°C	-25 ... 70
Switching Cycles over Lifetime		10.000
Standard		S800-RSU-H IEC60947-2 Annex N S800W-RSU UL489
Protection		IP20
Weight	g	300
Connection		10 pole Micro Fit 3.0

Technical data

Accessories

Short-circuit current limiter S803S-SCL		
Rated operational current I_e	A	32, 63, 125
Pole		3
Rated operational voltage U_e (AC) 50/60 Hz	V	400/690
Rated insulation voltage U_i	V	690
Rated impulse withstand voltage U_{imp}	kV	8
Rated ultimate short-circuit breaking capacity I_{cu} compliant to IEC 60947-2		
400 VAC	kA	100
440 VAC	kA	100
690 VAC	kA	50
Rated service short-circuit breaking capacity I_{cs} compliant to IEC 60947-2		100% I_{cu}
Rated frequency	Hz	50/60
Mounting position		any
Disconnecter properties compliant to IEC 60947-2		yes
Standard		IEC 60947-2
Connections C_u (32 A)	mm ²	1...25 strand 1...35 cable
Connections C_u (63, 125 A)	mm ²	6...50 strand 6...70 cable
Tightening torque	Nm	3.5
Feed		any
Mounting on DIN top hat rail		EN 60715
Permissible operating ambient temperature	°C	-25 ... +60
Storage temperature	°C	-40 ... +70
Protection category		IP20 IP40 (actuating end only)
Classification compliant to NF-16-101, NF16-102		I3, F2
Vibration resistance		IEC 60068-2-27; IEC 60068-2; EN 61373 Cat.1/Class B

Rated current I_n [A]	Internal resistance R_i [mΩ]	Power loss P_v [W]
32	1.7	1.7
63	1.0	4.0
125	0.6	9.4

Technical data

Accessories

Self-resetting short-circuit current limiter		S800S-SCL-SR	S803W-SCL-SR
Rated operational current I_e	A	32, 63, 100	
Pole		1, 2, 3	3
Rated operational voltage U_e (AC) according to IEC 60947-2 50/60Hz	V	400/690	690
(AC) according to UL 508 50/60Hz	V		600
Rated insulation voltage U_i	V	690	690
Rated impulse withstand voltage U_{imp}	kV	8	8
Rated ultimate short-circuit breaking capacity $I_{cu} = I_{cs}$ according to IEC 60947-2*			
(AC) 50/60 Hz 240/415 V	kA	100	100
(AC) 50/60 Hz 254/440 V	kA	100	100
(AC) 50/60 Hz 289/500 V	kA	65	65
(AC) 50/60 Hz 400/690 V	kA	50	50
Short-circuit rating according to UL 508*			
(AC) 50/60 Hz 480 V	kA	65	65
(AC) 50/60 Hz 600 V	kA	65	65
Rated frequency	Hz	50/60	50/60
Mounting position		any	any
Connections C_u	mm ²	1 ... 50 rigid (solid/stranded)	1 ... 50 rigid (solid/stranded)
	mm ²	1 ... 70 flexible	1 ... 70 flexible
	AWG		14-1
Tightening torque	Nm	3.5	3.5
	in. lbs.		31
Feeding		optional	optional
Mouting on DIN top hat rail		EN 60715	EN 60715
Ambient air temperature	°C	-40 ... +70	-40 ... +70
	°C	-40 ... +85	-40 ... +85
Degree of protection		IP20	IP20
Classification acc. to NF F 16-101, NF F 16-102		I3, F2	I3, F2
Damp Heat		IEC 60068-2-30, 55 °C / 95 % r.h.	IEC 60068-2-30, 55 °C / 95 % r.h.
Vibration		IEC 60068-2-6, 5-10 Hz / 3 mm and 10-500 Hz / 2 g at 0.5 x I_e	IEC 60068-2-6, 5-10 Hz / 3 mm and 10-500 Hz / 2 g at 0.5 x I_e
Random Vibration		IEC 60068-2-64, 5-500 Hz / 2 g at 0.5 x I_e	IEC 60068-2-64, 5-500 Hz / 2 g at 0.5 x I_e
Resistance to climatic conditions		IEC 60068-2-1 /-2-2 /-2-30	IEC 60068-2-1 /-2-2 /-2-30
Standard		IEC 60947-2 IEC 60947-4-1	IEC 60947-2 IEC 60947-4-1 UL 508, CSA 22.2 No. 14

* Valid only for approved combinations

Please have a look to separate coordination tables on pages 3/28 - 3/30

Technical data

S803HV-SCL-SR

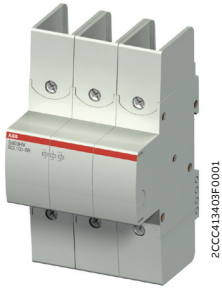

S803HV-SCL-SR in combination with S803HV-K

General data

Standard	IEC 60947-2	
Poles	3	
Rated frequency f	Hz	50/60

Data acc. to IEC 60947-2

Rated operational voltage U_e	V	AC 580/1000
Rated operational current I_n	A	32, 63, 100
Rated ultimate short-circuit breaking capacity I_{cu}	kA	15
Rated service short-circuit capacity I_{cs}	kA	10
Rated insulation voltage U_i	V	AC 1000
Rated impulse withstand voltage U_{imp}	kV	8

Mechanical data

Housing	Material group I, RAL 7035	
Toggle	black, lockable	
Protection degree acc. to IEC / EN 60529	IP20; IP40 (actuating side only)	
Classification acc. to NF F16-101, NF F 16-102	I3, F2	
Classification acc. to IEC 61373 (shock and vibration)	Cat. 1, Class B	
Shock resistance acc. to IEC / EN 60068-2-27	Test Ea: 5g / 30ms	
Vibration resistance acc. to IEC / EN 60068-2-6	Test Fc: 2-13.2 Hz / 1 mm 13.2-100 Hz / 0.7 g with load 100% x I_e	
Environmental conditions (damp heat) acc. to IEC / EN 60068-2-30	12+12 cycle with 55 °C / 90 - 96% RH and 25 °C / 95 - 100% RH	
Environmental conditions (dry heat) acc. to IEC / EN 60068-2-2	16 hours 55 °C / 2 hours 70 °C / 55% RH	
Ambient temperature	°C	-25 ... +60
Storage temperature	°C	-40 ... +70

Installation

Terminal	Failsafe cage terminal	
Connection (top/bottom) – C_u only	mm ²	1 ... 50 solid / stranded 1 ... 70 flexible
Tightening torque	Nm	3.5
Screwdriver	POZI 2	
Mounting	EN 60715	
Mounting position	any	
Supply side	any	

Dimension and weight

Pole dimension (H x L x W)	mm	142 x 76.5 x 26.5
Pole weight	kg	0.25

Internal resistance at 25 °C ambient temperature and nominal power losses

Rated current I_n [A]	Internal resistance R_i [mΩ]	Power loss P_v [W]
32	2.8	3.6
63	1.3	5.7
100	0.7	7.8

Technical data

Accessories

Internal resistance at 25°C ambient temperature and nominal power losses

Rated current I_n [A]	Internal resistance R_i [mΩ]	Power loss P_v [W]
32	2.8	3.6
63	1.3	5.7
100	0.7	7.8

Influence of ambient temperature – single mounted devices

Rated operational current I_e [A]	10°C	15°C	20°C	25°C	30°C	35°C	40°C	45°C	50°C	55°C	60°C	65°C	70°C
32	38.2	37.2	35.8	35.2	34.2	33.3	32	30.7	29.8	28.8	27.8	26.5	25.1
63	75.3	73.2	70.6	69.3	67.4	65.5	63	60.5	58.6	56.7	54.8	52.3	49.8
100	119.5	116.2	112	110	107	104	100	96	93	90	87	84	80

Installation requirements

The total sum of the rated currents of all downstream motor starters or circuit breakers shall not exceed the rated current of the S800-SCL-SR (valid also for HV version). Furthermore the sum of all load currents including inrush currents shall not exceed the maximum permissible load of the S800-SCL-SR (valid also for HV version).

Maximum load

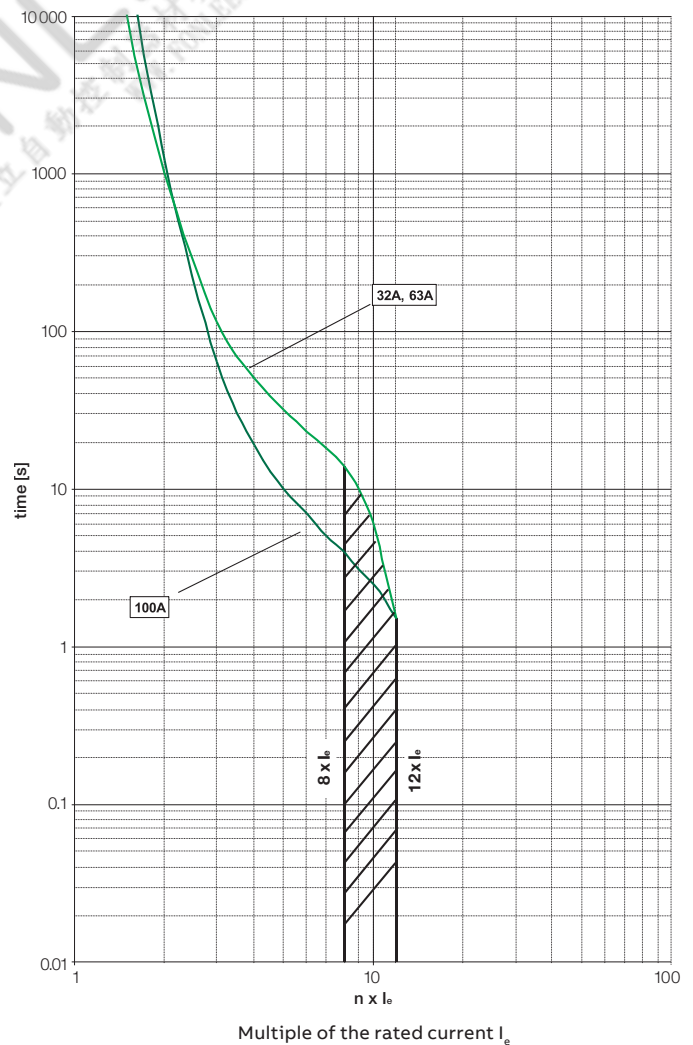

Approved combinations

S800-SCL-SR/S803S-SCL with S800 and motor starters

A new web tool SOC - Selected Optimized Coordination is now available at http://applications.it.abb.com/SOC_SNB and can be used to find all the available combinations between S800 portfolio and other ABB devices:

- Motor starting and protection
- Selectivity among protection devices
- Back-up among protection devices
- Protection of other equipments like switch-disconnectors

Approved combinations with high performance MCB S800

Downstream devices	Upstream devices					
	S800S-SCL-SR/S803W-SCL-SR Self resetting short-circuit limiter			S803S-SCL Short-circuit limiter		
Rated current I _n [A]	32	63	100	32	63	125
S800S Characteristic B						
6	•					
8	•					
10	•	•	•	•		
13	•	•	•	•		
16	•	•	•	•		
20	•	•	•	•		
25	•	•	•	•		
32	•	•	•	•	•	
40		•	•		•	
50		•	•		•	
63		•	•		•	•
80			•			•
100			•			•
125						•
S800S Characteristic C						
6	•					
8	•					
10	•	•	•	•		
13	•	•	•	•		
16	•	•	•	•		
20	•	•	•	•		
25	•	•	•	•		
32		•	•	•	•	
40		•	•		•	
50		•	•		•	
63			•		•	•
80			•			•
100						•
125						•
S800S Characteristic D/K						
6	•					
8	•					
10	•	•	•	•		
13	•	•	•	•		
16	•	•	•	•		
20		•	•	•		
25		•	•	•		
32		•	•	•	•	
40		•	•		•	
50			•		•	
63			•		•	•
80						•
100						•
125						•

Approved combinations

S800-SCL-SR/S803S-SCL with S800 and motor starters

Approved combinations with motor starter/S800S-KM

Downstream devices	Upstream devices					
	S800S-SCL-SR/S803W-SCL-SR Self resetting short-circuit limiter			S803S-SCL Short-circuit limiter		
Rated current I _n [A]	32	63	100	32	63	125
MS/MO325						
0.1 - 2.5	●	●	●			
4	●	●	●			
6.3	●	●	●			
9	●	●	●	●	●	
12.5	●	●	●	●	●	
16	●	●	●	●	●	
20		●	●	●	●	
25		●	●	●	●	
MS/MO132						
0.1 - 2.5	●	●				
4	●	●				
6.3	●	●	●			
9	●	●	●	●	●	
12.5	●	●	●	●	●	
16		●	●	●	●	
20		●	●	●	●	
25		●	●	●	●	
MS132-T						
0.1 - 2.5	●	●				
4	●	●				
6.3	●	●	●			
9	●	●	●	●	●	
12.5	●	●	●	●	●	
16		●	●	●	●	
20		●	●	●	●	
25		●	●	●	●	
S800S-KM						
20		●	●	●		
25		●	●	●		
32		●	●	●	●	
40		●	●		●	
50			●		●	
63					●	●
80						●

* Motor starter combinations acc. to IEC 60947-4-1

- Applies for all voltages according to the table below

Approved combinations

S803HV-SCL-SR with S800

Approved combinations with S803HV-K

Downstream devices	Upstream devices		
	Upstream devices S803HV-SCL-SR Self resetting short-circuit limiter		
Rated current I_n [A]	32	63	100
S800HV Characteristic K			
6	•		
8	•		
10	•	•	•
13	•	•	•
16		•	•
20		•	•
25		•	•
32		•	•
40		•	•
50			•
63			•
80			
100			
125			

Applies for all voltages according to the table below

	S800S-SCL-SR	S803W-SCL-SR	S803S-SCL	S803HV-SCL-SR
Rated ultimate short-circuit breaking capacity				
$I_{cu} = I_{cs}$ according to IEC 60947-2				
(AC) 50/60 Hz 240/415 V	kA 100	100		
(AC) 50/60 Hz 254/440 V	kA 100	100	100	
(AC) 50/60 Hz 277/480 V	kA 65	65		
(AC) 50/60 Hz 289/500 V	kA 65	65		
(AC) 50/60 Hz 346/600 V	kA 65	65		
(AC) 50/60 Hz 400/690 V	kA 50	50	50	
(AC) 50/60 Hz 580/1000 V	kA			$I_{cu} = 15 \text{ kA}$ $I_{cs} = 10 \text{ kA}$
Short-circuit rating according to UL 508, CSA 22.2				
(AC) 50/60 Hz 480 V	kA	65		
(AC) 50/60 Hz 600 V	kA	65		

Technical data

Accessories

Shunt release S800-SOR

		S800-SOR12	S800-SOR24	S800-SOR130	S800-SOR250	S800-SOR400
Rated operational voltage U_e	VAC/DC	12	24	48 ... 130	110 ... 250	220 ... 400
Operating range	% U_e	70 ... 110	70 ... 110	70 ... 110	70 ... 110	70 ... 110
Rated insulation voltage U_i	V	690	690	690	690	690
Coil pull in consumption	W/VA	15.5	16.6/17*	41.9 ... 307.3 42 ... 310*	23 ... 119 20 ... 105*	45 ... 148.1
Rated frequency	Hz	DC; 50/60	DC; 50/60	DC; 50/60	DC; 50/60	DC; 50/60
Pollution degree		3	3	3	3	3
Standard		IEC 60947-2/ UL 489	IEC 60947-2/ UL 489	IEC 60947-2/ UL 489	IEC 60947-2/ UL 489	IEC 60947-2/ UL 489
Connection C_u	mm ²	1 ... 25 (14-2 AWG) strand 1 ... 35 (14-3 AWG) cable	1 ... 25 (14-2 AWG) strand 1 ... 35 (14-3 AWG) cable	1 ... 25 (14-2 AWG) strand 1 ... 35 (14-3 AWG) cable	1 ... 25 (14-2 AWG) strand 1 ... 35 (14-3 AWG) cable	1 ... 25 (14-2 AWG) strand 1 ... 35 (14-3 AWG) cable
Tightening torque	Nm	3.5	3.5	3.5	3.5	3.5
AC/DC supply		any	any	any	any	any
Mounting on DIN top hat rail		EN 60715	EN 60715	EN 60715	EN 60715	EN 60715
Protection category		IP20 IP40 (actuating end only)	IP20 IP40 (actuating end only)	IP20 IP40 (actuating end only)	IP20 IP40 (actuating end only)	IP20 IP40 (actuating end only)
Permissible operating ambient temperature	°C	-25 ... +60	-25 ... +60	-25 ... +60	-25 ... +60	-25 ... +60
Storage temperature	°C	-40 ... +70	-40 ... +70	-40 ... +70	-40 ... +70	-40 ... +70
Vibration resistance		IEC 60068-2-6; EN 61373 Cat.1/ Class B	IEC 60068-2-6; EN 61373 Cat.1/ Class B	IEC 60068-2-6; EN 61373 Cat.1/ Class B	IEC 60068-2-6; EN 61373 Cat.1/ Class B	IEC 60068-2-6; EN 61373 Cat.1/ Class B

Technical data

Accessories

Undervoltage release S800-UVR

		S800-UVR36	S800-UVR60	S800-UVR130	S800-UVR250
Rated operational voltage U_e	VAC/DC	24 ... 36	48 ... 60	110 ... 130	220 ... 250
Operating range					
open	% U_e	35 ... 70	35 ... 70	35 ... 70	35 ... 70
closed	% U_e	85	85	85	85
Rated insulation voltage U_i	V	690	690	690	690
Power loss of coil when attracted	W/VA	1.11 ... 1.14/1.2*	1.14 ... 1.25/1.3*	1.3 ... 1.41/1.4*	1.71 ... 1.91/1.9*
Rated frequency	Hz	DC; 50/60	DC; 50/60	DC; 50/60	DC; 50/60
Pollution degree		3	3	3	3
Standard		IEC 60947-2 / UL 489	IEC 60947-2 / UL 489	IEC 60947-2 / UL 489	IEC 60947-2 / UL 489
Connection C_u	mm ²	1 ... 25 (14-2 AWG) strand 1 ... 35 (14-3 AWG) cable	1 ... 25 (14-2 AWG) strand 1 ... 35 (14-3 AWG) cable	1 ... 25 (14-2 AWG) strand 1 ... 35 (14-3 AWG) cable	1 ... 25 (14-2 AWG) strand 1 ... 35 (14-3 AWG) cable
Tightening torque	Nm	3.5	3.5	3.5	3.5
AC/DC supply		any	any	any	any
Mounting on DIN top hat rail		EN 60715	EN 60715	EN 60715	EN 60715
Protection category		IP20 IP40 (actuating end only)	IP20 IP40 (actuating end only)	IP20 IP40 (actuating end only)	IP20 IP40 (actuating end only)
Permissible operating ambient temperature	°C	-25 ... +60	-25 ... +60	-25 ... +60	-25 ... +60
Storage temperature	°C	-40 ... +70	-40 ... +70	-40 ... +70	-40 ... +70
Vibration resistance		IEC 60068-2-6; EN 61373 Cat.1/Class B	IEC 60068-2-6; EN 61373 Cat.1/Class B	IEC 60068-2-6; EN 61373 Cat.1/Class B	IEC 60068-2-6; EN 61373 Cat.1/Class B

Busbar S803-BB250/S804-BB250

Max. rated current I_n		
Side feed	A	125
Middle feed	A	250
Conditional rated short-circuit current	kA eff	100 with T_{max} connected upstream
Poles		3/4
Rated operational voltage U_e		
(AC) 50/60 Hz	V	400/690
Rated insulation voltage U_i	V	690
Rated impulse withstand voltage U_{imp}	kV	8
Rated frequency	Hz	50
Standard		EN/IEC 60439-2
Material of rails		E- C_u 58 half-standard, rolled F25
Material of insulation profile		Material group I; UL94 V-0
Material of end caps		Material group I; UL94 V-0 Free of halogen and phosphate
Busbar cross sections	mm ²	60
Overvoltage category		III
Pollution degree		2

Technical data

Accessories

Feed block S803-BBPC120/S804-BBPC120

Max. rated current I_n	A	250
Poles		3/4
Rated operational voltage U_e	V	400/690
Rated frequency	Hz	50
Standard		EN/IEC 60439-2
Material of terminals		Material group I
Housing material		Material group I; UL94 V-0, Free of halogen and phosphate
Tightening torque		-
on feed side	Nm	19
on busbar side	Nm	3
Connection cross-section	mm ²	1.6...120
Pollution degree		2

Pole connector S802-LINK125

Rated insulation voltage U_i	V	DC 1200
Protection category	Nm	3.5
Tightening torque	in. lbs.	31

Combination S800PV-SP with S802-LINK50 / -LINK125 (devices mounted separately)

I_e [A]	10°C	15°C	20°C	25°C	30°C	35°C	40°C	45°C	50°C	55°C	60°C
10	11.6	11.4	11.2	11.0	10.7	10.4	10.0	9.6	9.3	9.0	8.7
13	15.1	14.9	14.6	14.3	13.9	13.5	13.0	12.5	12.1	11.7	11.3
16	18.6	18.2	17.9	16.6	17.1	16.6	16.0	15.4	14.9	14.4	13.9
20	23.2	22.8	22.4	22.0	21.4	20.8	20.0	19.2	18.6	18.0	17.4
25	29.0	28.5	28.0	27.5	26.8	26.0	25.0	24.0	23.3	22.5	21.8
32	37.1	36.5	35.8	35.2	34.2	33.3	32.0	30.7	29.8	28.8	27.8
40	46.5	45.6	44.8	44.0	42.8	41.6	40.0	38.4	37.2	36.0	34.8
50	58.1	57.0	56.0	55.0	53.5	52.0	50.0	48.0	46.5	44.6	42.9
63	69.9	68.8	67.6	66.5	65.3	64.2	63.0	60.5	58.1	55.7	53.5
80	88.8	87.3	86.0	84.4	82.9	81.5	80.0	76.8	73.7	70.8	67.9
100	111.0	109.2	107.3	105.6	103.7	101.8	100.0	96.0	92.2	88.5	84.9
125	138.8	136.5	134.2	131.9	129.6	127.3	125.0	116.3	108.1	100.5	93.5

These values are valid for the combination with S802-LINK50

Combination S800PV-SD with S802-LINK50 / -LINK125 (devices mounted separately)

I_e [A]	10°C	15°C	20°C	25°C	30°C	35°C	40°C	45°C	50°C	55°C	60°C
32	32	32	32	32	32	32	32	32	32	32	32
63	63	63	63	63	63	63	63	63	63	63	63
125	125	125	125	125	125	125	110	110	100	100	100

The tables are based on measurements using cable as stated in IEC 60947-2. Any derivation from these cable diameters and lengths might lead to higher temperatures. Therefore

ABB recommends to perform temperature measurements to verify the real maximum temperature in the application.

Technical data

Accessories



CMS-120DR



CMS-120CA

Open core sensors 18 mm

Sensor type		CMS-120xx	CMS-121xx	CMS-122xx
Measurement range	A	80	40	20
Measurement values		TRMS, AC 50/60 Hz, DC		
Crest factor of disorted wave forms		≤1.5	≤3	≤6
AC Accuracy (TA = +25°C)*		≤ ± 1 %		
AC Temperature coefficient*		≤ ± 0.04 %		
DC Accuracy (TA = +25°C)*		≤ ± 1.2 %	≤ ± 1.4 %	≤ ± 1.8 %
Operating temperature		≤ ± 0.14 %	≤ ± 0.24 %	≤ ± 0.44 %
Resolution	A	0.01		
Sampling rate internal	Hz	5000		
Settling time (±1%)	sec	Type 0.34		
Cable feed through	mm	9.6		
Insulation Voltage	V	690 VAC/1500 VDC		
Operating temperature	°C	-25 ... +70/ -40 ... +85		
Size				
CMS-120DR series	mm	17.4 x 51.5 x 43.2		
CMS-120CA series	mm	17.4 x 41.0 x 29.0		
Reference standard		IEC 61010-1 UL508 / CSA C22.2 No 14		

* All accuracy specifications refer to full scale value and apply at 25° C. In the case of open-core sensors, the position of the cable affects accuracy.

Solid-core sensors 18 mm



CMS-100S8



CMS-100DR



CMS-100CA

Sensor type		CMS-100xx	CMS-101xx	CMS-102xx
Measurement range	A	80	40	20
Measurement values		MS, AC 50 / 60 Hz, DC		
Crest factor of disorted wave forms		≤1.5	≤3	≤6
AC Accuracy (TA = +25°C)*		≤ ± 0.5 %		
AC Temperature coefficient*		≤ ± 0.036 %		
DC Accuracy (TA = +25°C)*		≤ ± 0.7 %	≤ ± 1.0 %	≤ ± 1.7 %
Operating temperature		≤ ± 0.047 %	≤ ± 0.059 %	≤ ± 0.084 %
Resolution	A	0.01		
Sampling rate internal	Hz	5000		
Settling time (±1%)	sec	Type 0.25		
Cable feed through	mm	10		
Insulation Voltage	V	690 VAC/1500 VDC		
Operating temperature	°C	-25 ... +70/ -40 ... +85		
Size				
CMS-100S8 series	mm	26.5 x 45.5 x 31.8		
CMS-100DR series	mm	17.4 x 51.5 x 43.2		
CMS-100CA series	mm	17.4 x 41.0 x 29.0		
Reference standard		IEC 61010-1 UL508 / CSA C22.2 No 14		

* All accuracy specifications refer to the relevant full scale value and apply at 25° C.

Technical data

Accessories



CMS-200S8



CMS-200DR



CMS-200CA

Solid-core sensors 25 mm

Sensor type		CMS-200xx	CMS-201xx	CMS-202xx
Measurement range	A	160	80	40
Measurement values		TRMS, AC 50 / 60 Hz, DC		
Crest factor of distorted wave forms		≤1.5	≤3	≤6
AC Accuracy (TA = +25 °C)*		≤ ± 0.5 %		
AC Temperature coefficient*		≤ ± 0.036 %		
DC Accuracy (TA = +25 °C)*		≤ ± 0.7 %	≤ ± 1.0 %	≤ ± 1.7 %
DC Temperature coefficient*		≤ ± 0.047 %	≤ ± 0.059 %	≤ ± 0.084 %
Resolution	A	0.01		
Sampling rate internal	Hz	5000		
Settling time (±1 %)	sec	Type 0.25		
Cable feed through	mm	15		
Insulation Voltage	V	690 V AC /1500 V DC		
Operating temperature	°C	25 ... +70 / - 40 ... + 85		
Size				
CMS-200S8 series	mm	26.5 x 43.0 x 38.5		
CMS-200DR series	mm	25.4 x 43.0 x 43.2		
CMS-200CA series	mm	25.4 x 43.0 x 35.7		
Reference standard		IEC 61010-1 UL508 / CSA C22.2 No 14		

* All accuracy specifications refer to the relevant full scale value and apply at 25 °C.

Technical data

Accessories



CMS-600

CMS-600 Control Unit

Supply voltage	VDC	24 (± 10 %)
Power loss	W	4-24 (depending on the number of sensors)
Interface		2-wire RS485
Protocol		Modbus RTU
Data transmission speed	Baud	2400... 115200
Refresh time		≤1 sec. with max. 64 sensors
Insulation voltage	VAC	400
Screw terminals		0.5 ... 2.5 mm ² , max. 0.6 Nm
Installation method		35-mm DIN Rail (DIN 50022)
Dimensions	mm	71.8 x 87.0 x 64.9 (4 DIN modules)
Operating temperature	C°	- 25 ... +70
Storage temperature	C°	- 40 ... +85
Reference standards		IEC 61010-1 UL 508/CSA C22.2 no. 14



CMS-700

CMS-700 Control Unit

IEC61010-1		
Supply voltage	VAC	90-240 (L1-N)
Voltage measurement range	VAC	90-240 (L1-N, L2-N, L3-N)
UL 508 / CSA C22.2 No. 14		
Supply voltage	VAC	80-277 (L1-N)
Voltage measurement range	VAC	80-277 (L1-N, L2-N, L3-N)
General		
Frequency	Hz	50/60
Power consumption (L1-N)	W	5 ... 40 (depending on the number of sensors)
Measurement range, current transformer, secondary side		nominal: 5 max: 6
Modbus RTU data rate	Baud	2-wire RS485, 2400 ... 115200
Data update speed		≤1 sec. with max. 96 sensors
LAN	Mbit/s	100
Cable cross-section	mm ²	1.0.. 2.5 mm ² , max. 0.8 Nm
Installation method		35-mm DIN Rail (DIN 50022)
Protection degree		IP20
Overvoltage category		II
Altitude	m	2000
Dimensions	mm	160.0 x 87.0 x 64.9 (9 DIN modules)
Operating temperature	C°	- 25 ... +60
Storage temperature	C°	- 40 ... +85
Standards		
Electrical safety		IEC 61010-1, UL 508, CSA C22.2 No.14
EMC		EC61326-1

Mains accuracy

Voltage	± 1 %
Current	± 1 %
Harmonic components (up to 2500Hz)	± 1 %
Active power	± 2 %
Apparent power	± 2 %
Reactive power	± 2 %
Power Factor	± 0.2 %

Technical data

Accessories

DDA800 residual current device

		DDA800AC	DDA800A	DDA800AS	DDA800A AP-R
Standard		IEC/EN 60947-2 Ann.B			
Sensitivity		AC	A	A (selective)	A (with short-term delay)
Rated current	A	63	63, 100	63, 100	63, 100
Number of poles		2P; 3P; 4P	2P; 3P; 4P	2P; 3P; 4P	2P; 3P; 4P
Rated insulation voltage U_i	V	690	690	690	690
Rated operational voltage U_e	V	230/400; 240/415; 400/690	230/400; 240/415; 400/690	230/400; 240/415; 400/690	230/400; 240/415; 400/690
Max. Rated operational voltage U_b max.	V	690	690	690	690
Min. Rated operational voltage U_b min.	V	195	195	195	195
Rated ultimate short-circuit breaking capacity I_{cu} compliant to IEC 60947-2		Depends on ultimate breaking capacity of MCB's	Depends on ultimate breaking capacity of MCB's	Depends on ultimate breaking capacity of MCB's	Depends on ultimate breaking capacity of MCB's
Rated ultimate short-circuit breaking capacity I_{Am} with S800N	kA	Depends on ultimate breaking capacity of MCB's	Depends on ultimate breaking capacity of MCB's	Depends on ultimate breaking capacity of MCB's	Depends on ultimate breaking capacity of MCB's
Rated ultimate short-circuit breaking capacity I_{Am} with S800S	kA	Depends on ultimate breaking capacity of MCB's	Depends on ultimate breaking capacity of MCB's	Depends on ultimate breaking capacity of MCB's	Depends on ultimate breaking capacity of MCB's
Rated impulse withstand voltage U_{imp} Impulse (1.2/50)	kV	6	6	6	6
Rated impulse withstand voltage U_{imp} (50...60Hz) x 1min	kV	2.5	2.5	2.5	2.5
Max. operating voltage of test circuit	V	690	690	690	690
Min. operating voltage of test circuit	V	195	195	195	195
Electrical strength compliant to VDE	A		250	5000	3000
Rated frequency	Hz	50/60	50/60	50/60	50/60
Rated residual operating current I_{An}	A	0.03; 0.3	0.03; 0.3; 0.5	0.3; 1	0.03
Switch lever		blue, can only be switched in OFF position	blue, can only be switched in OFF position	blue, can only be switched in OFF position	blue, can only be switched in OFF position
Protection category, housing		IP4X (without terminal area)	IP4X (without terminal area)	IP4X (without terminal area)	IP4X (without terminal area)
Protection category, terminal		IP2X	IP2X	IP2X	IP2X
Permissible operating ambient temperature	°C	-25 ... +60	-25 ... +60	-25 ... +60	-25 ... +60
Permissible storage temperature	°C	-40 ... +70	-40 ... +70	-40 ... +70	-40 ... +70
Strand connections	mm ²	6 ... 50	6 ... 50	6 ... 50	6 ... 50
Cable connections	mm ²	6 ... 70	6 ... 70	6 ... 70	6 ... 70
Tightening torque	Nm	3.5	3.5	3.5	3.5
Fixed on mounting rail		EN 60715	EN 60715	EN 60715	EN 60715

230/400 V Let-through energies

S800S-B, -C, -D, -K

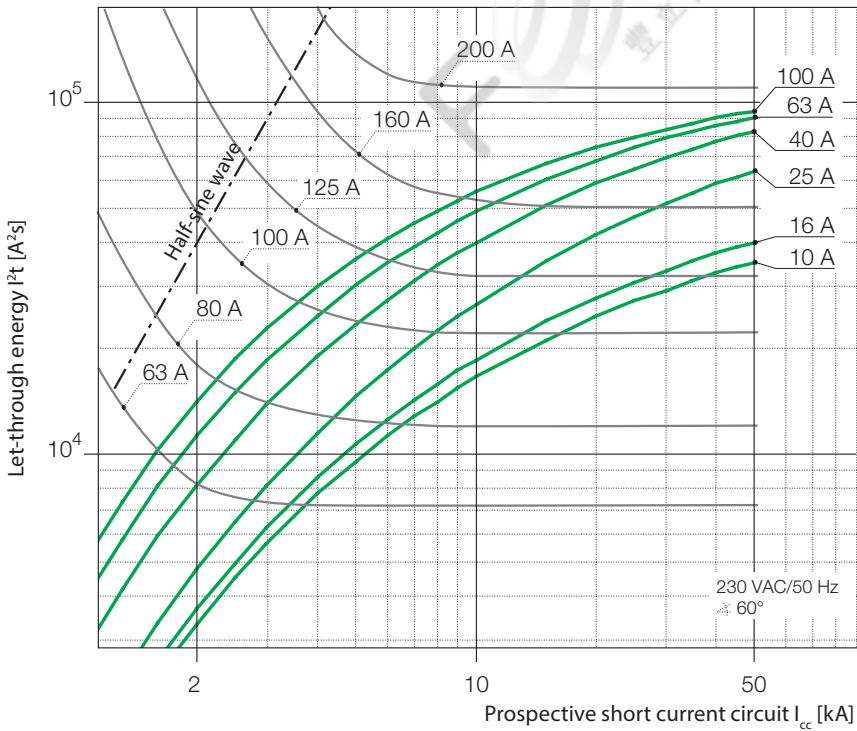
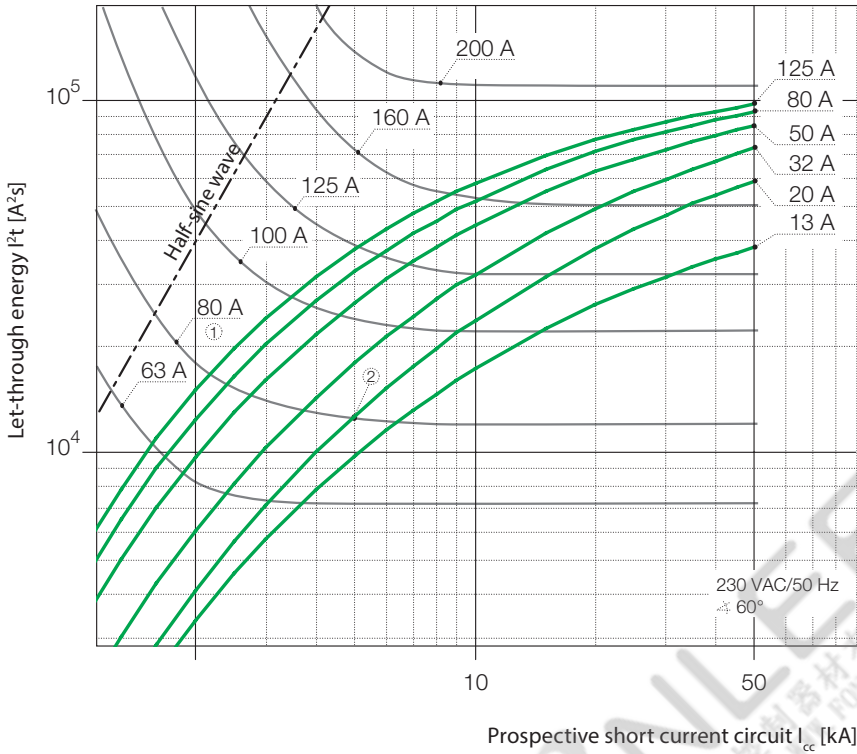

- ① Min. pre-arcing I²t, e.g. NH80A gL/gG
- ② Max. let-through I²t, e.g. S801S-C20

Selectivity with respect to the upstream fuse to the point of intersection of both curves 1 and 2, e.g. S801S-C20 to NH80A gL/gG: Selectivity up to min. 5 kA.

440V Let-through energies

S800S-B, -C, -D, -K

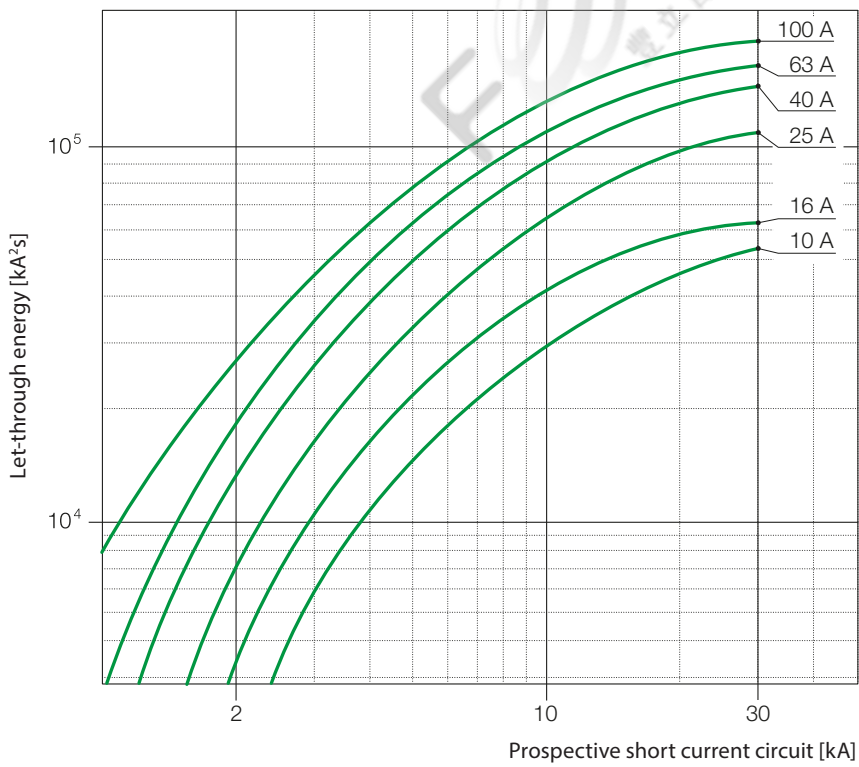
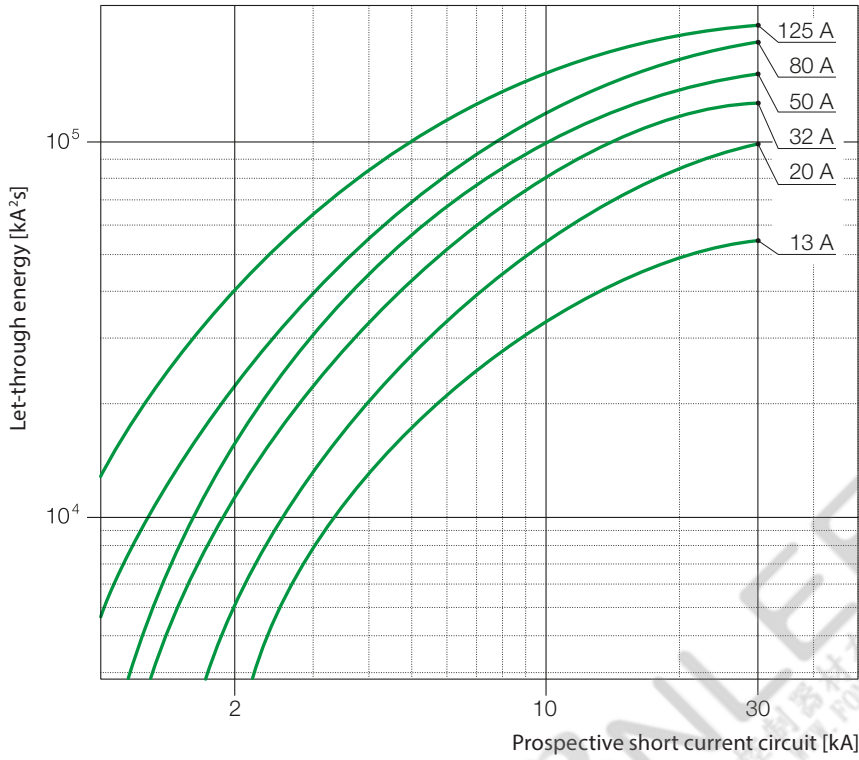

690 V Let-through energies

S800S-B, -C, -D, -K

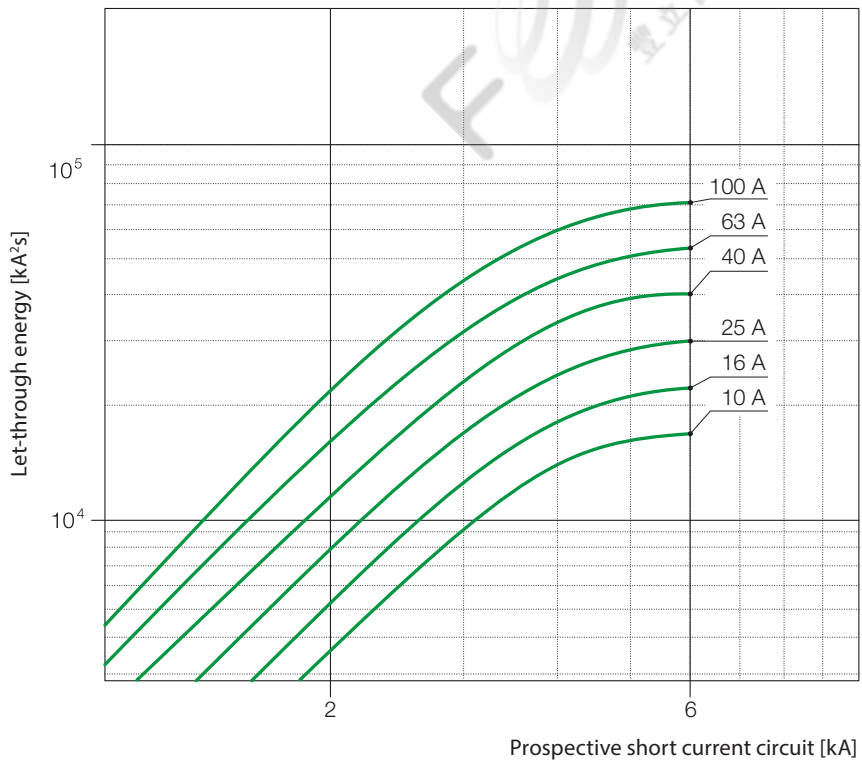
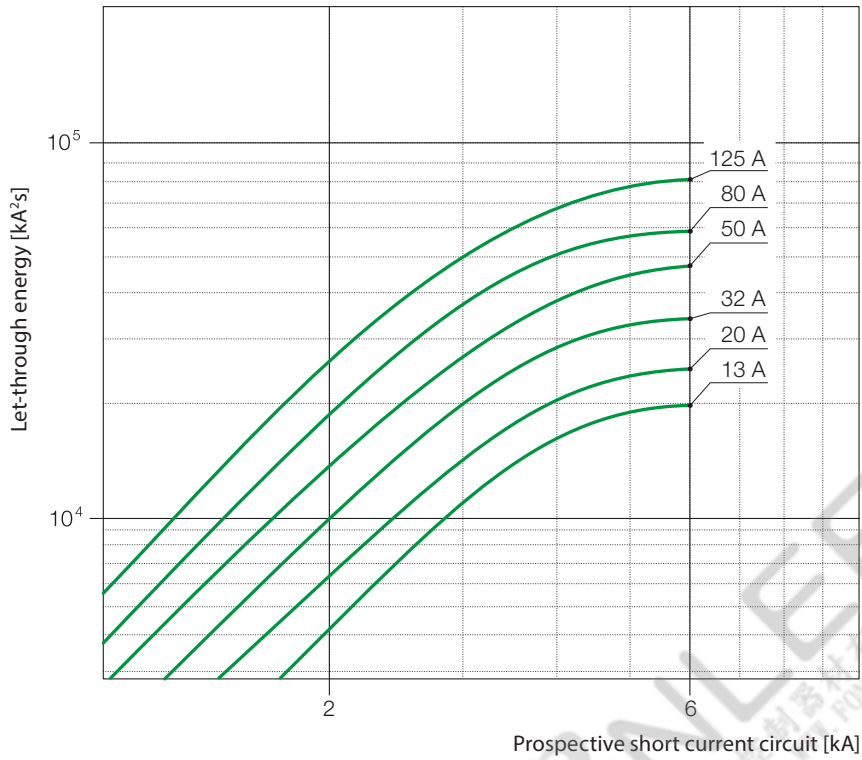

230/400 V Let-through energies

S800N-B, -C, -D

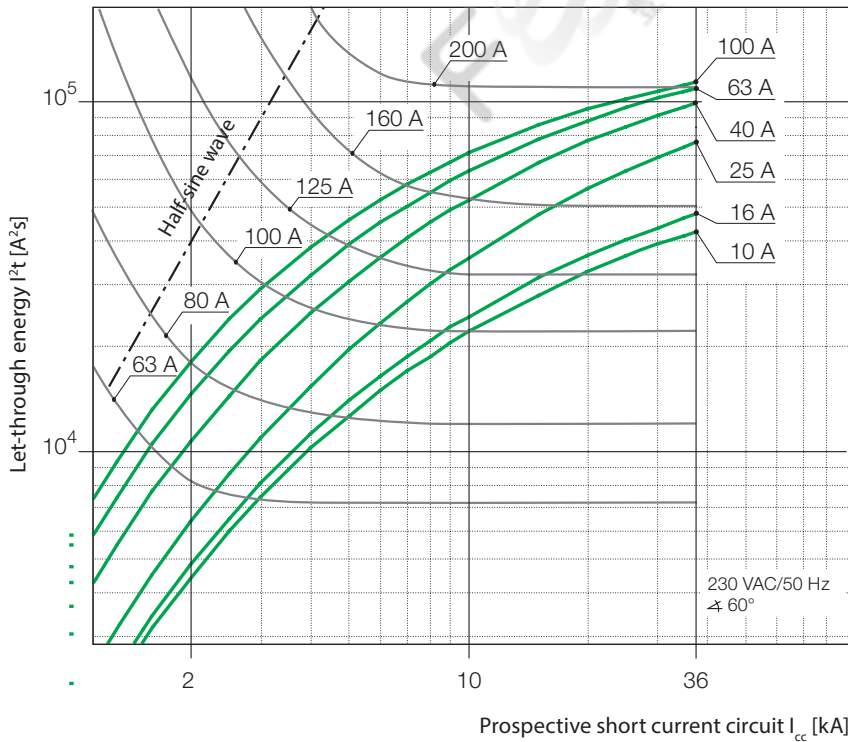
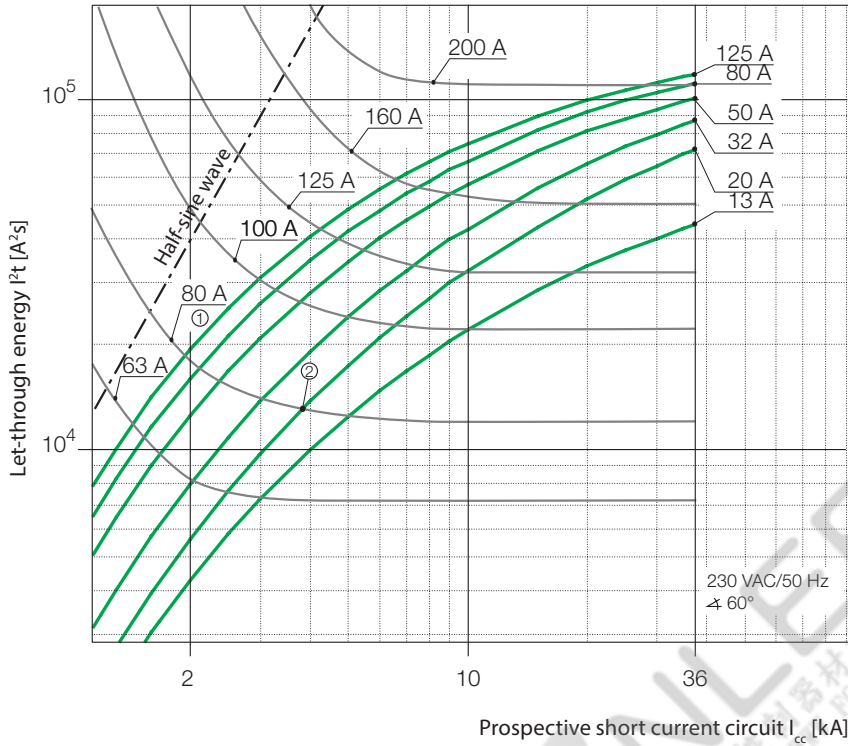

- ① Min. pre-arcing I²t, e.g. NH80A gL/gG
- ② Max. let-through I²t, e.g. S801N-C20

Selectivity with respect to the upstream fuse to the point of intersection of both curves 1 and 2, e.g. S801N-C20 to NH80A gL/gG: Selectivity up to min. 3.8 kA.

230/400 V Let-through energies

S800C-B, -C, -D, -K

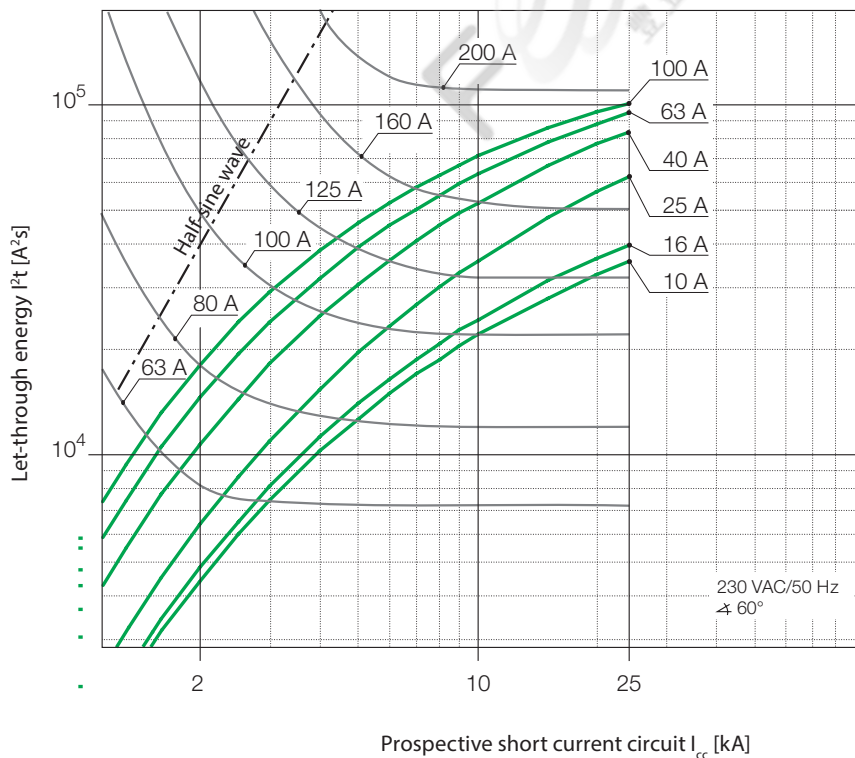
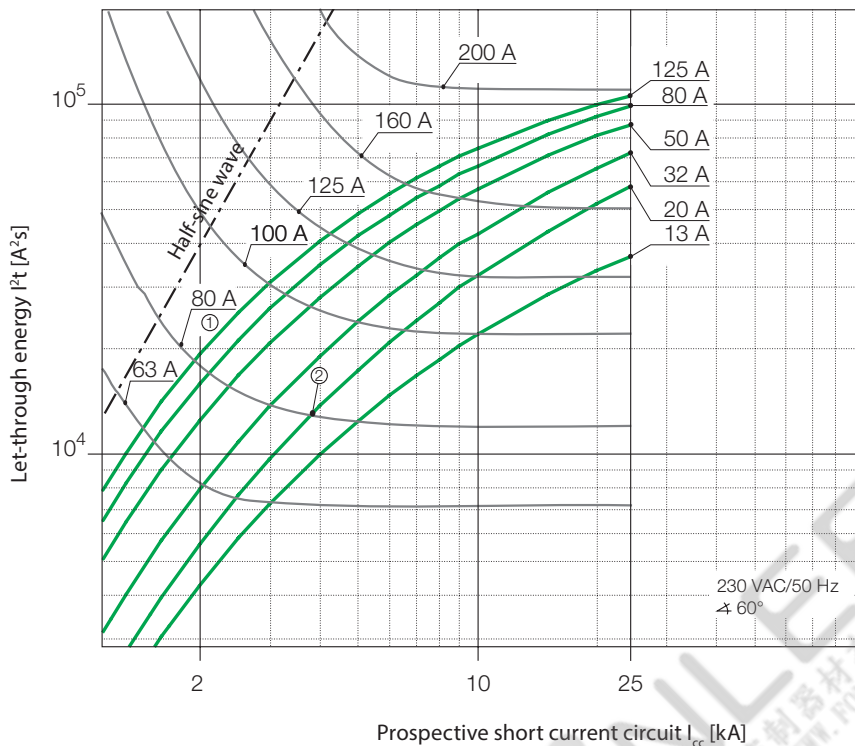

- ① Min. pre-arcing I²t, e.g. NH80A gL/gG
- ② Max. let-through I²t, e.g. S801C-C20

Selectivity with respect to upstream fuse to the point of intersection of both curves 1 and 2, e.g. S801C-C20 to NH80A gL/gG: Selectivity up to min. 3.8 kA

230/400 V Let-through energies

S800B-B, -C, -D, -K

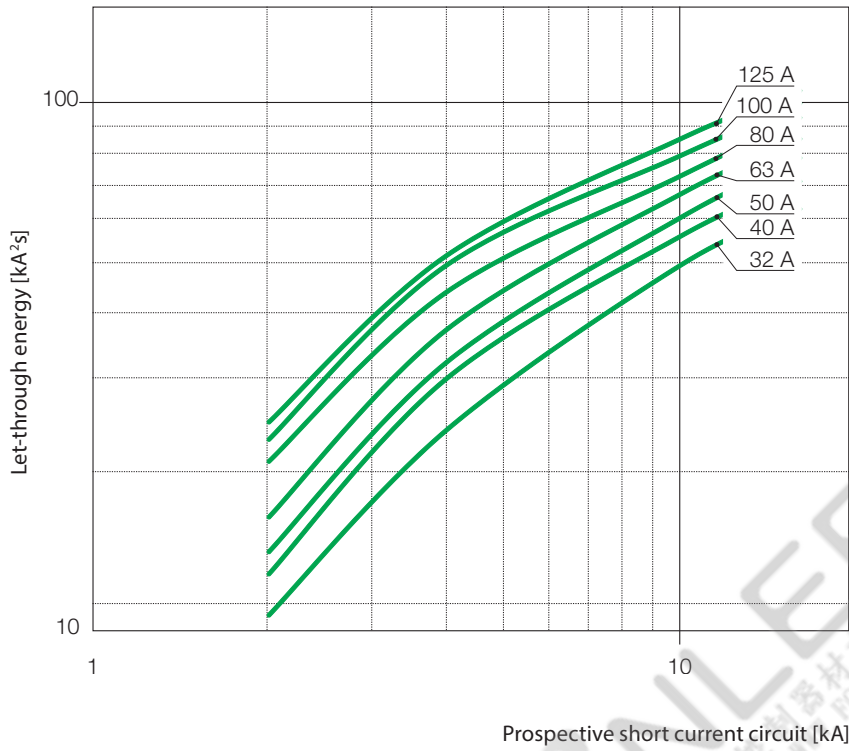

FONLEEE
豐立自動控制器材有限公司
FONLEEE.COM.TW

240V Let-through energies

S800U-Z, -K

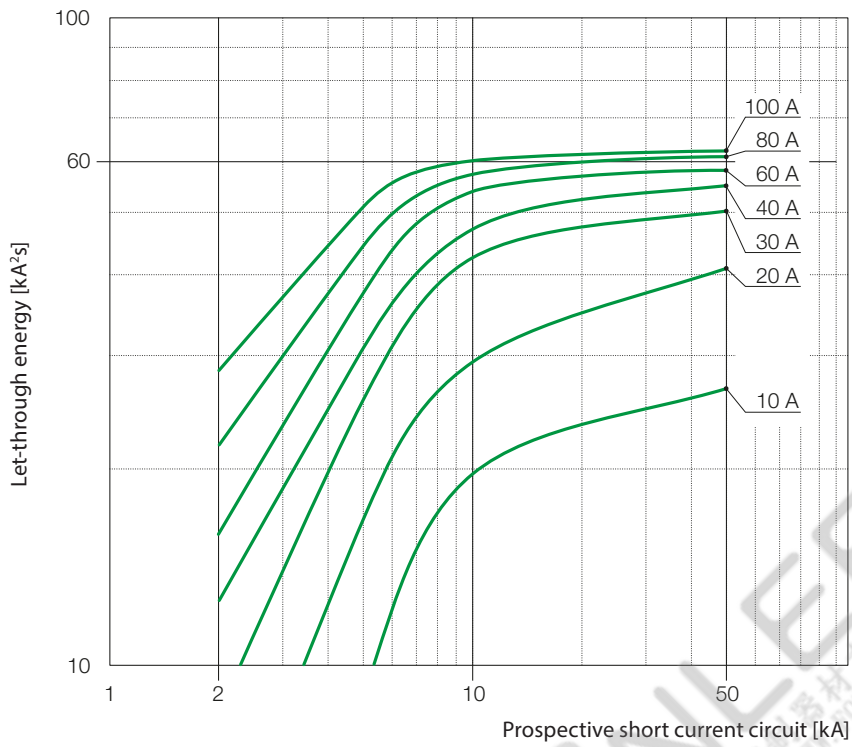

2CC04132820001

FOONLEE
豐立自動控制器材有限公司
WWW.FOONLEE.COM.TW

230/400 V Let-through current

S800S-B, -C, -D, -K

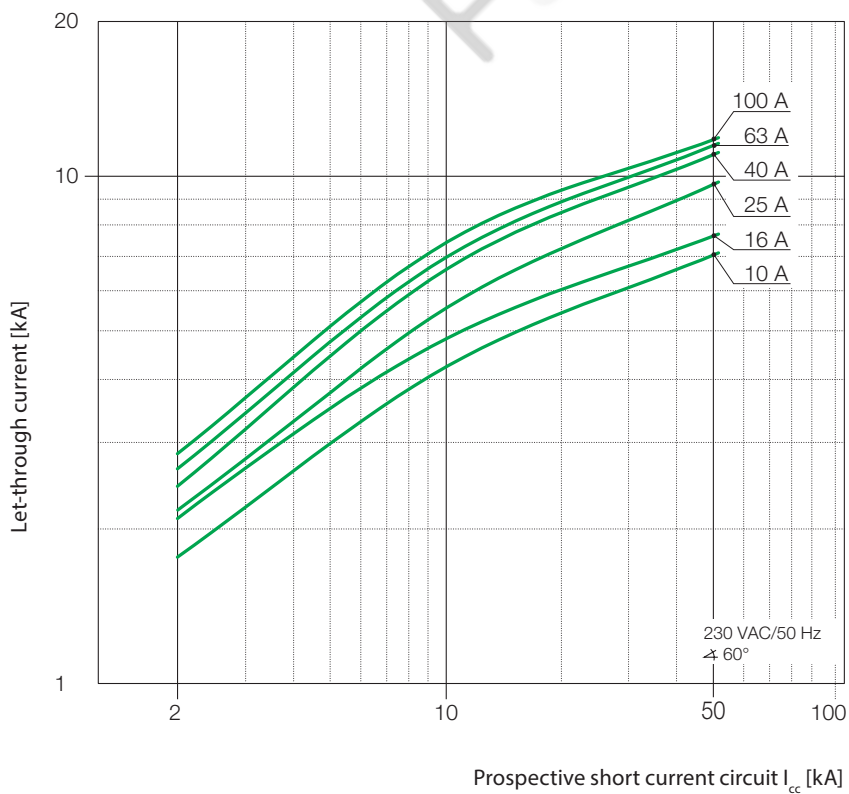
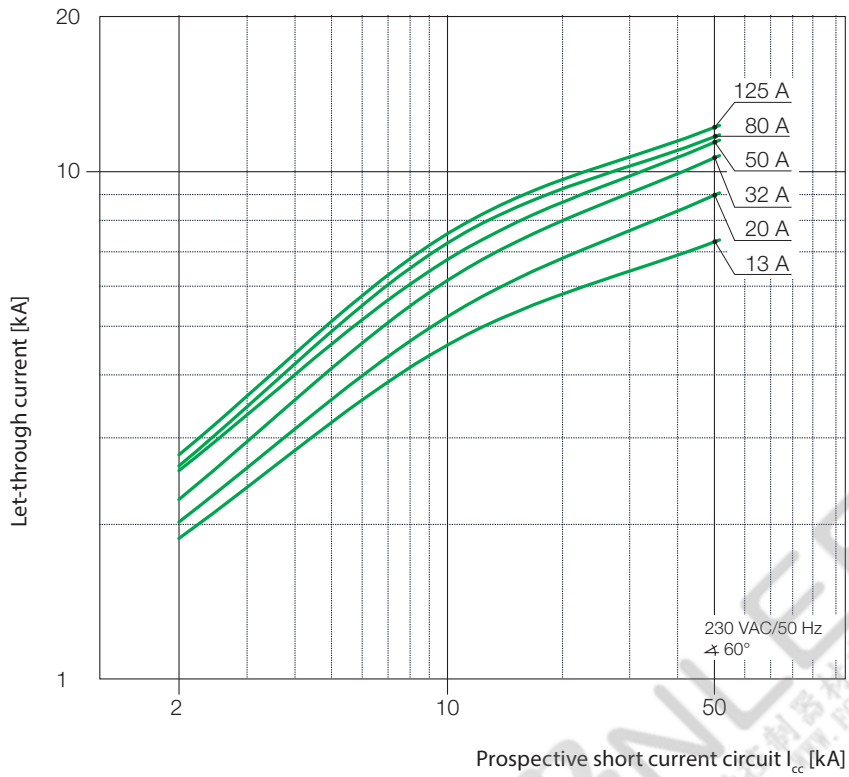

440V Let-through current

S800S-B, -C, -D, -K

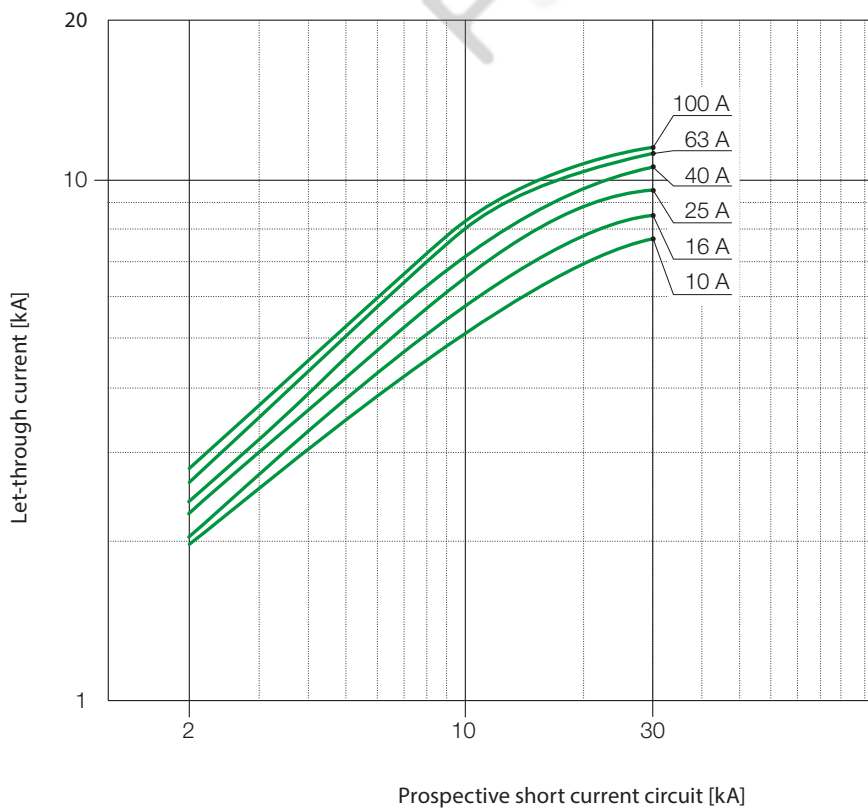
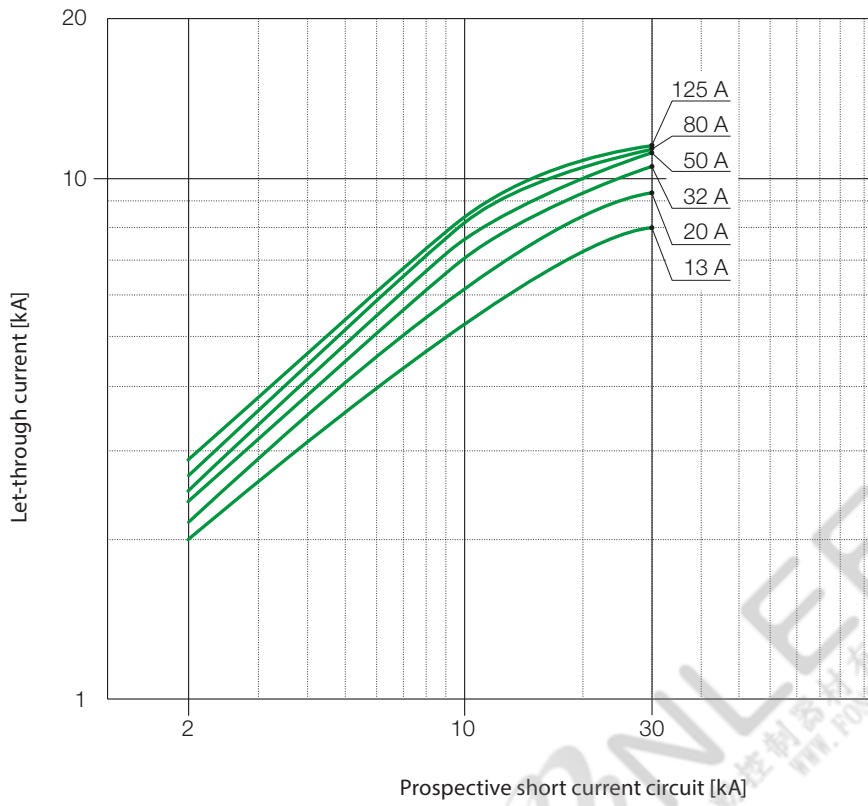

690 V Let-through current

S800S-B, -C, -D, -K

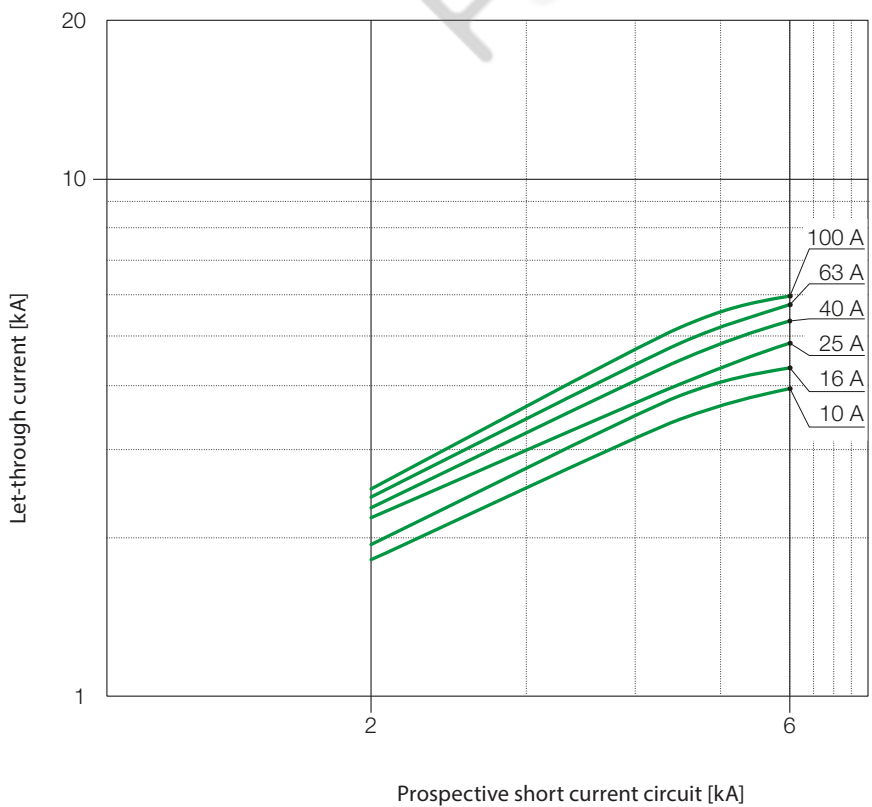
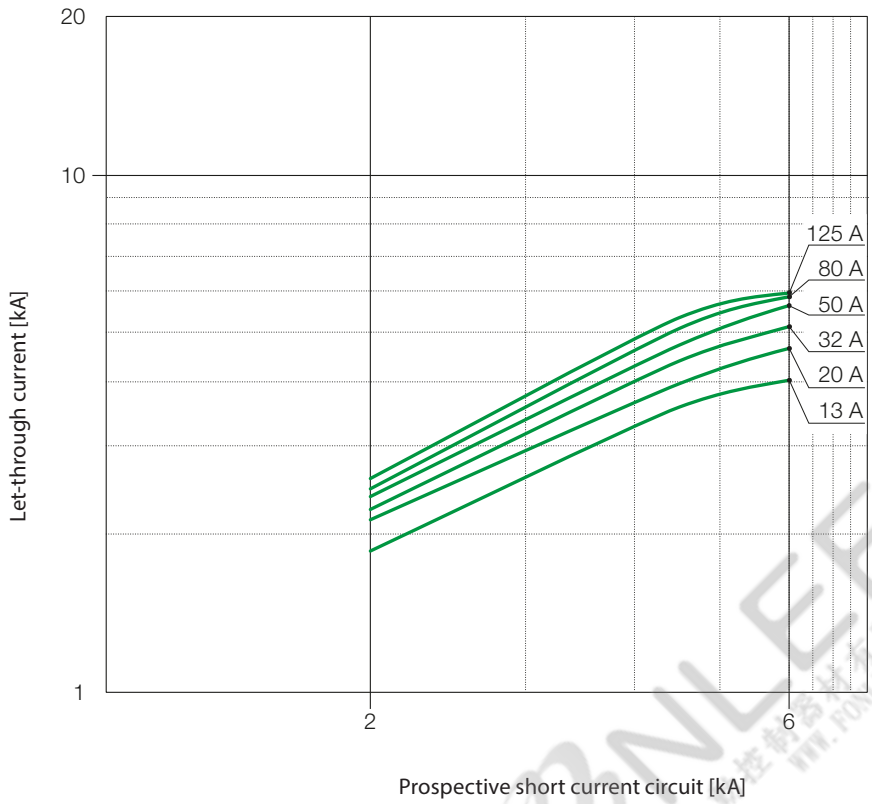

230/400 V Let-through current

S800N-B, -C, -D

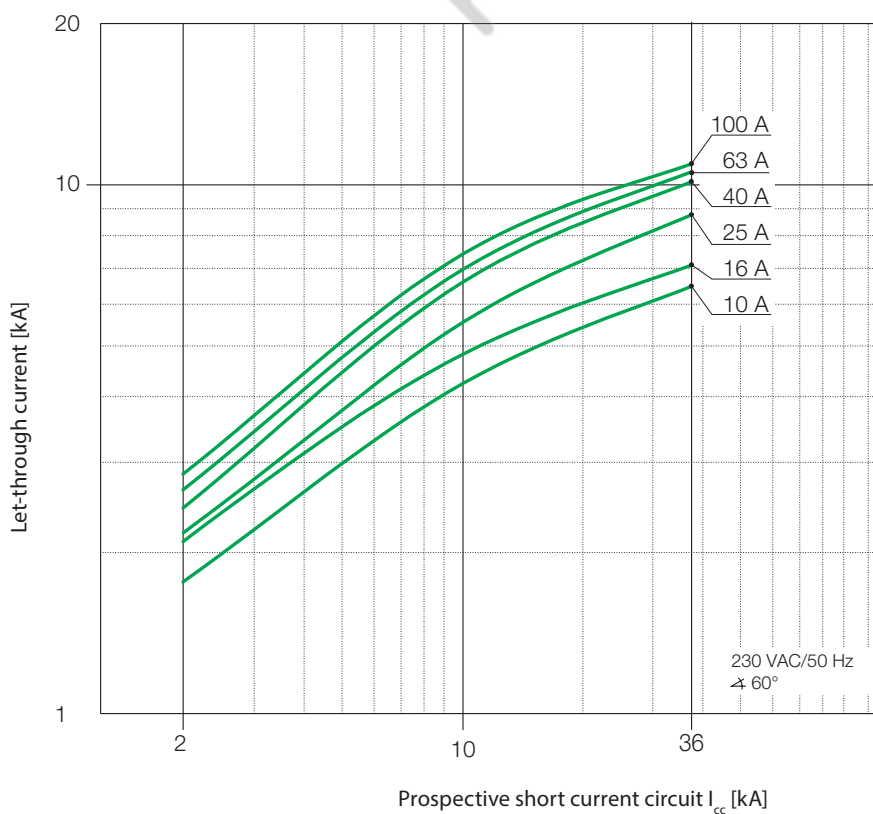
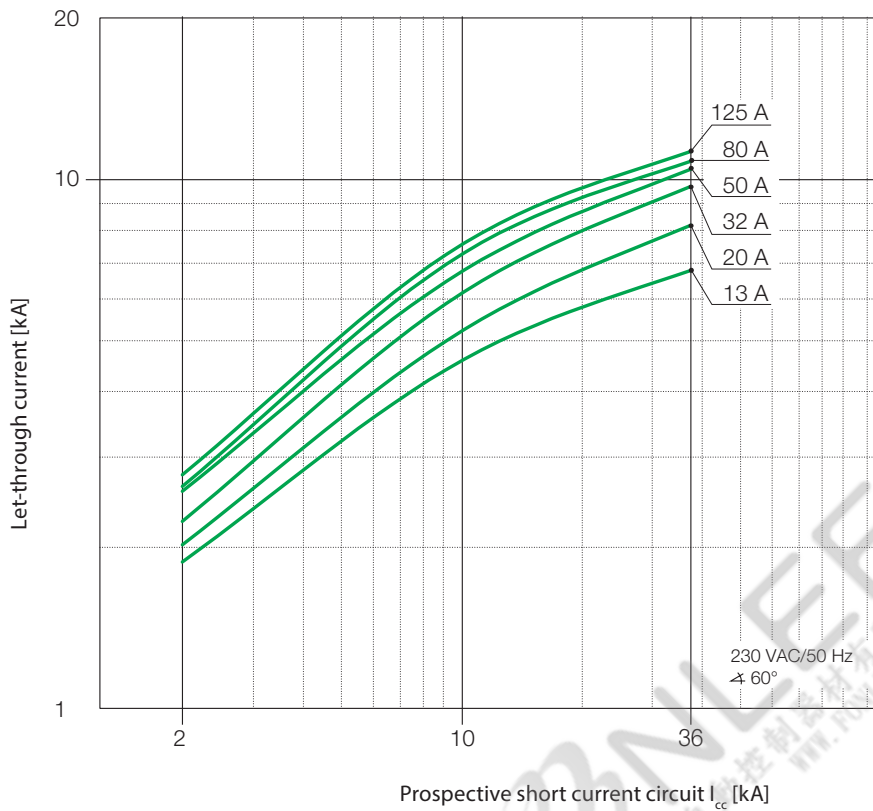

230/400 V Let-through current

S800C-B, -C, -D, -K

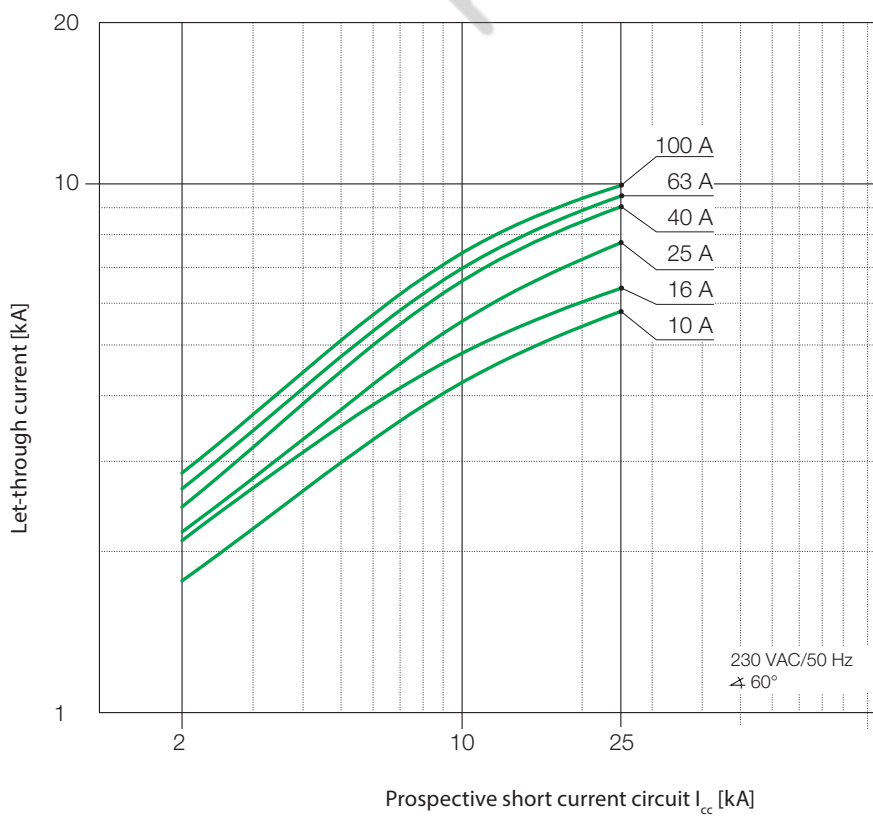
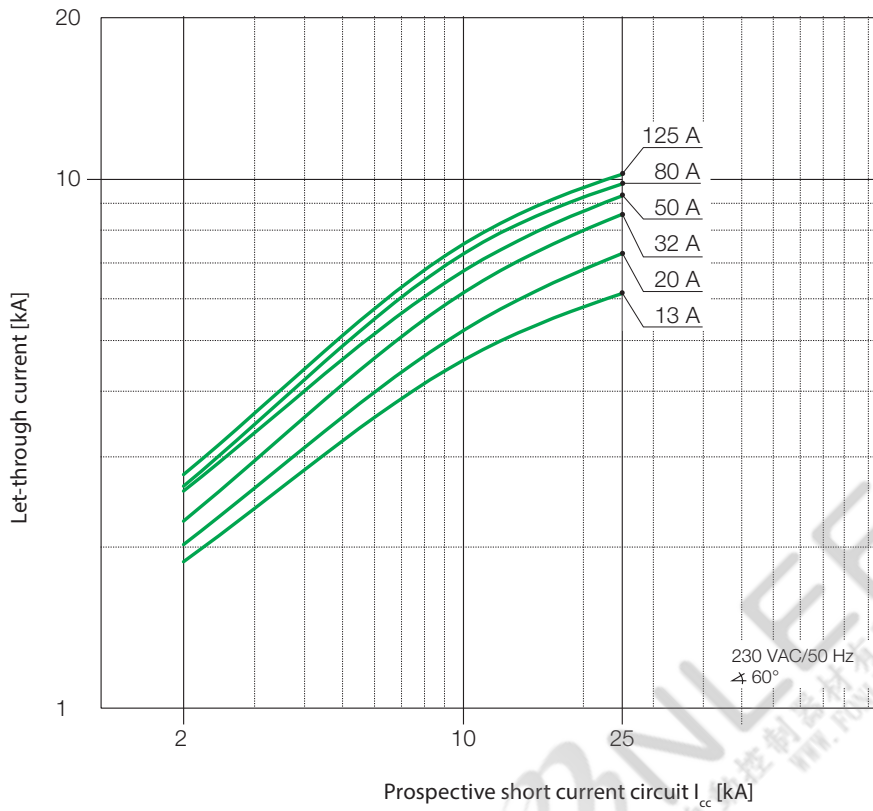

230/400 V Let-through current

S800B-B, -C, -D, -K

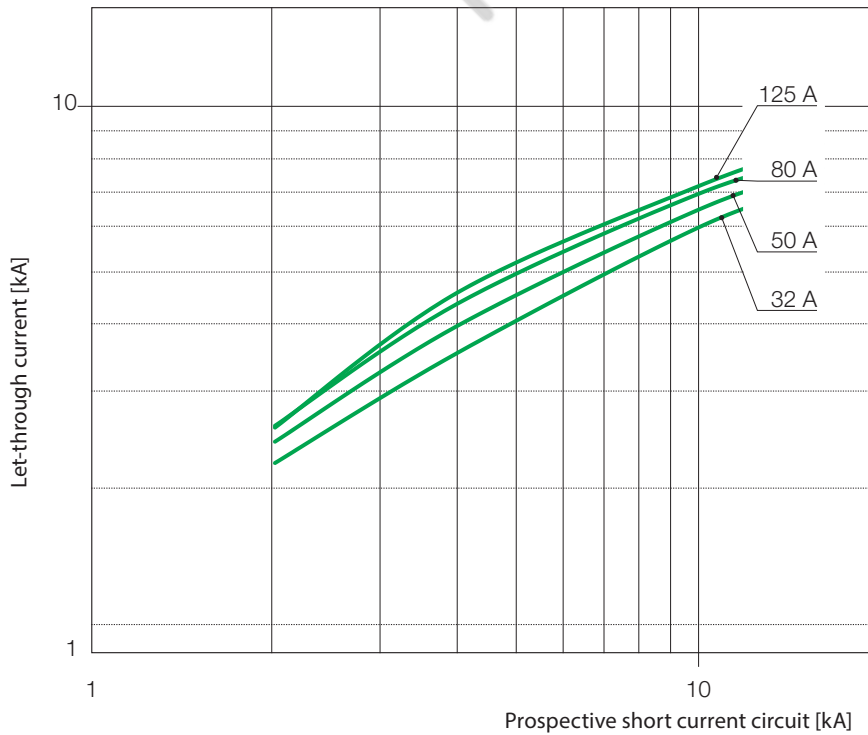
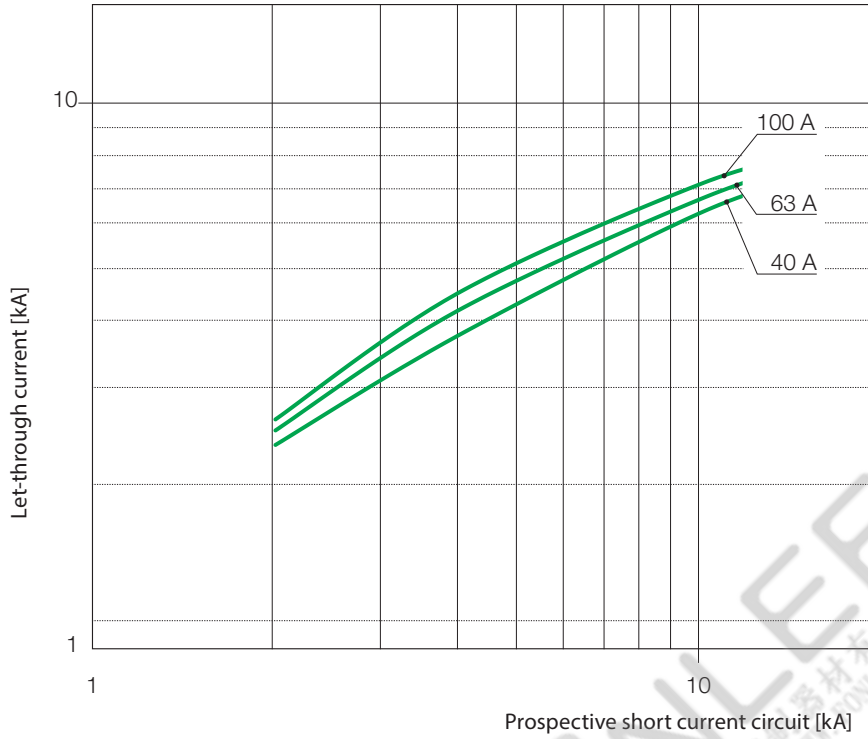

240V Let-through current

S800U-Z, -K

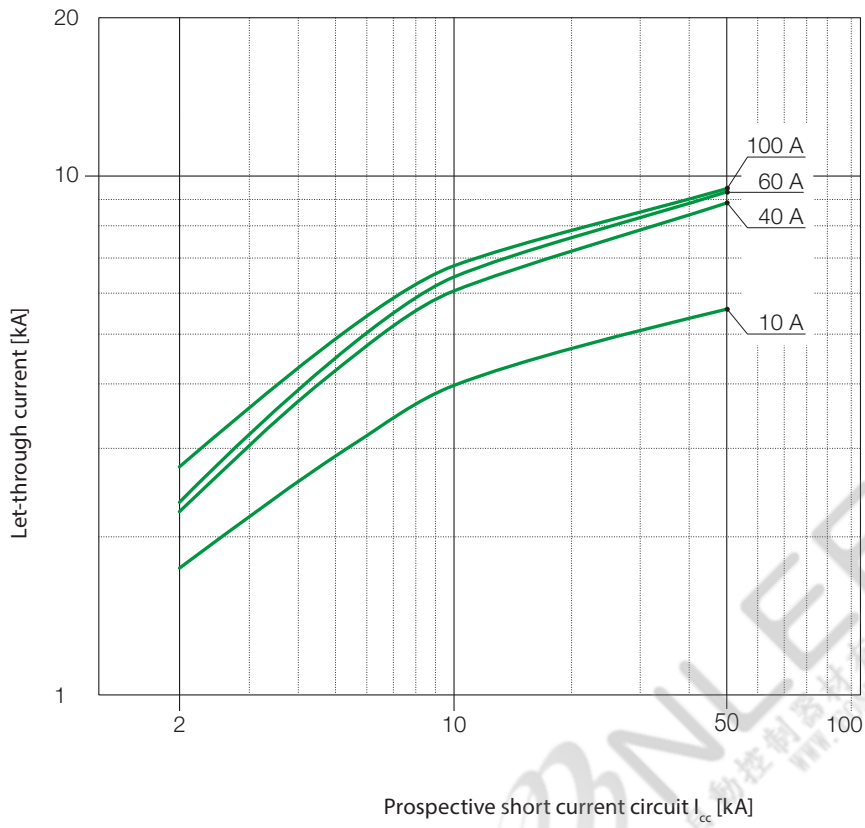

2CCC413287Z0001

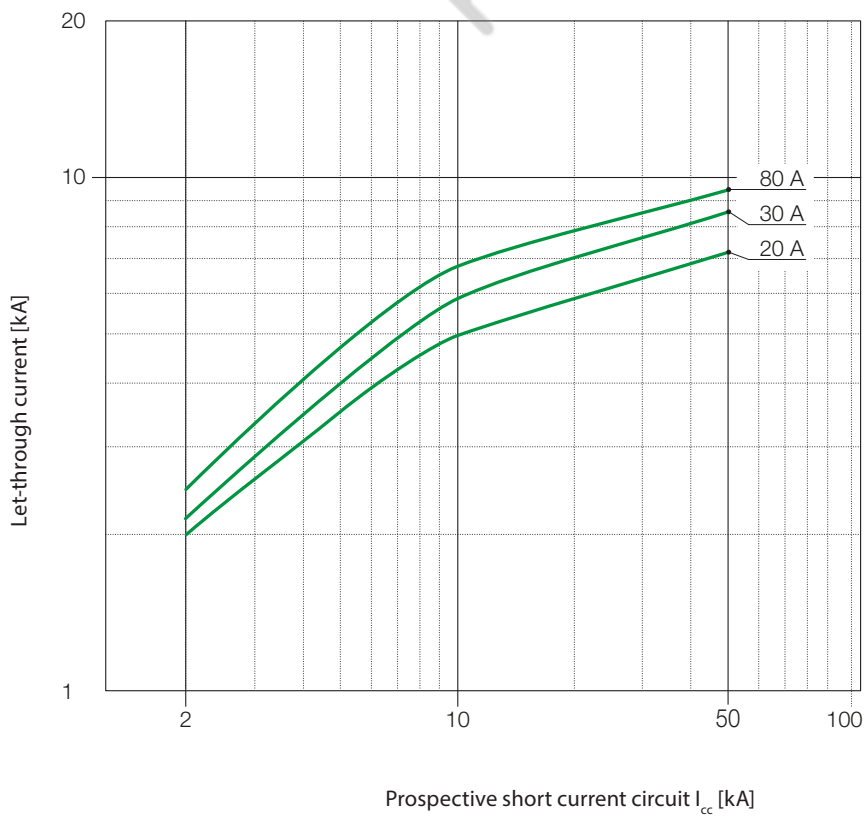

2CCC413288Z0001

FONLEE
豐立自動控制器材有限公司
www.fonlee.com.tw

Pole dimensions of S800

S800	4/3
S800S-R	4/3
Dimensions	
S800S, S800N, S800C	4/4
S800S, S800N, S800C, S800HV	4/4
S800HV-SCL-SR	4/4
S800-AUX	4/5
S800-AUX/ALT	4/5
S800-NT	4/5
S800-RSU-H	4/6
S800W-RSU	4/6
S803S-SCL	4/6
S800S-SCL-SR	4/6
S803W-SCL-SR, S803HV-SCL-SR	4/7
S800-SOR	4/7
S800-UVR	4/7
S800-BB250	4/7
S800-BBPC120	4/7
S800-RD + S800-RHE	4/8
S802-LINK50, S802-LINK125	4/8
CMS-100S8	4/8
CMS-200S8	4/8
CMS-600	4/9
DDA802	4/9
DDA803	4/9
DDA804	4/9
DS802	4/10
DS803	4/10
DS804	4/10

Pole dimensions

High performance MCB

S800S
S800N
S800C
S800B
S800U
S800PV-SP
S800PV-SD

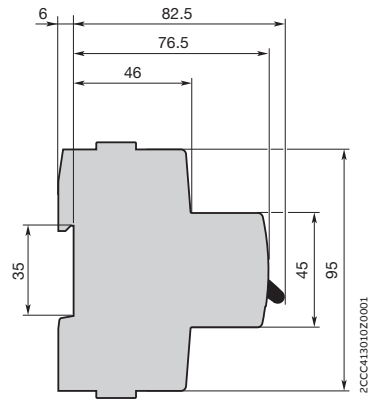
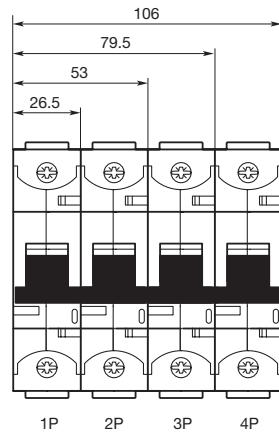

S800
with Ringlug
terminals

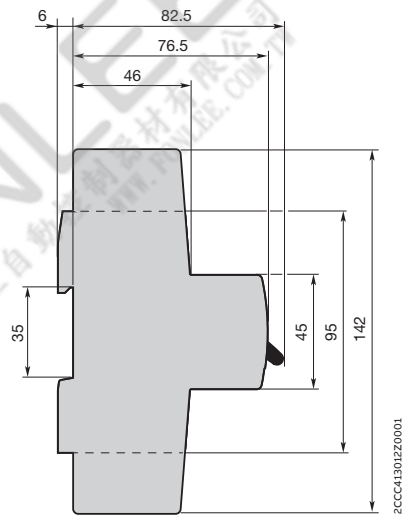
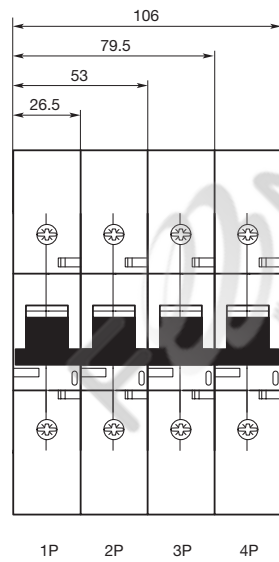

Dimensions

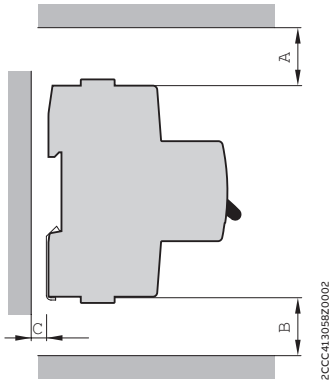

S800S, S800N, S800C		
up to 254/440 VAC or 500 VDC		
S800S-UC		
up to 1000 VDC		
S800S-SCL-SR		
up to 400/690 VAC		
Dimensions	isolated parts/surfaces	not isolated parts/surfaces
A	25	100
B	25	25
C	7	50

S800S, S800N, S800C, S800HV		
from 254/440 VAC up to 400/690 VAC or 588/1000 VAC (S800HV)		
S800B		
up to 230/400 VAC or 300 VDC		
S800PV-SP		
up to 1500 VDC		
Dimensions	isolated parts/surfaces	not isolated parts/surfaces
A	25	50
B	25	25
C	7	50

S800HV-SCL-SR		
up to 580/1000 Vac		
Dimensions	isolated parts/surfaces	not isolated parts/surfaces
A	25	150
B	25	25
C	7	50

Dimensions of accessories

S800-AUX

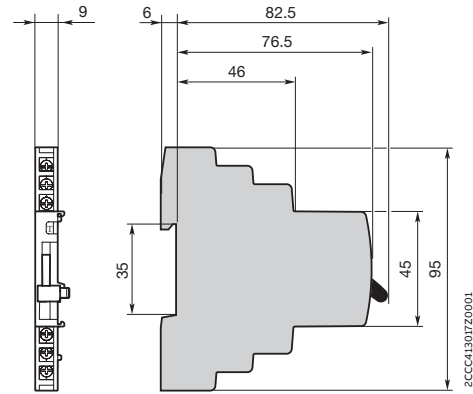

S800-AUX/ALT

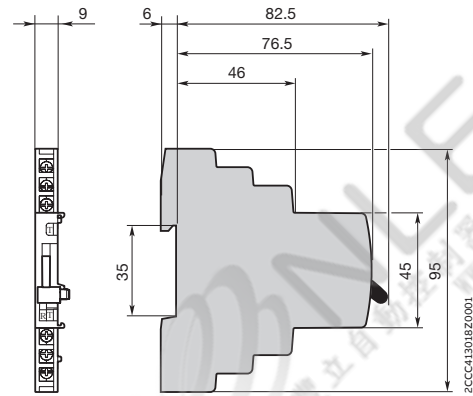

S800-NT

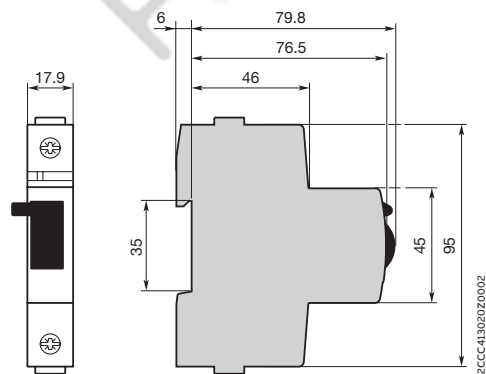

Pole dimensions

High performance MCB

S800-RSU-H

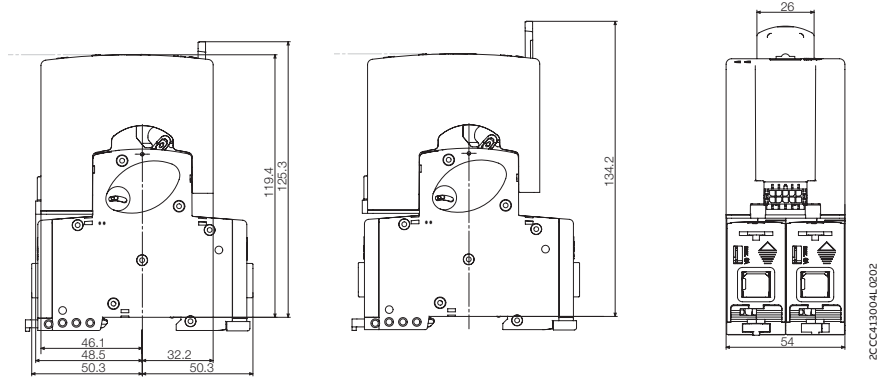

S800W-RSU

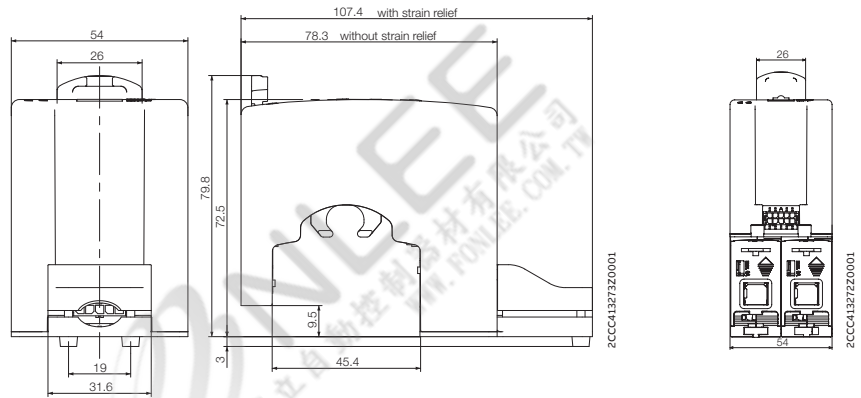

S803S-SCL

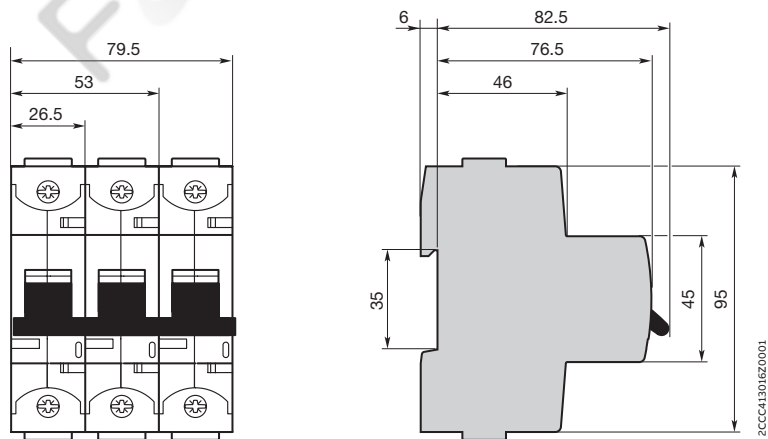

S800S-SCL-SR

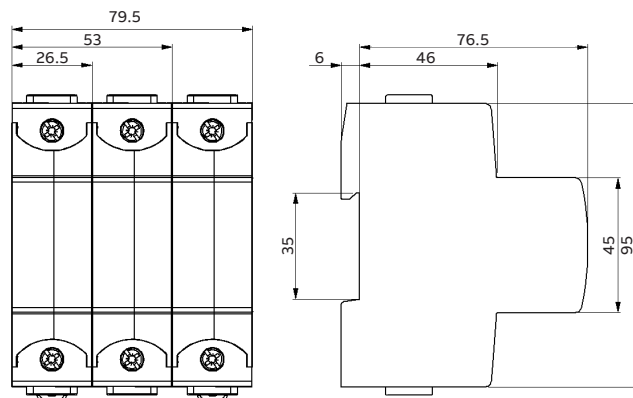

Dimensions of accessories

S803W-SCL-SR
S803HV-SCL-SR

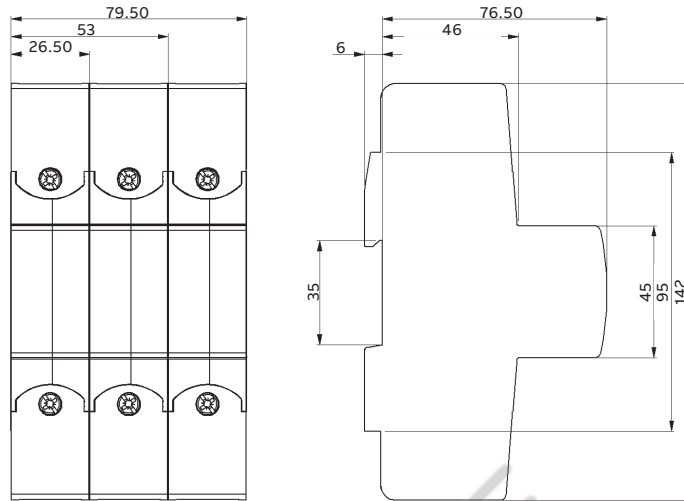

S800-SOR
S800-UVR

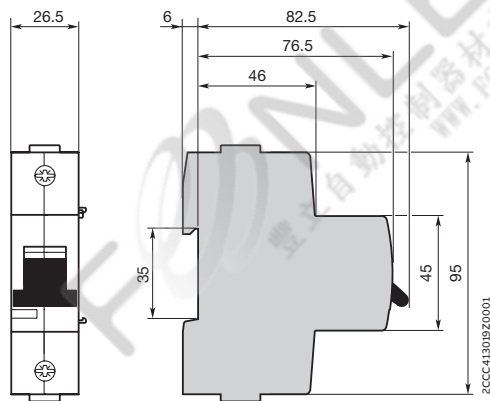

S800-BB250

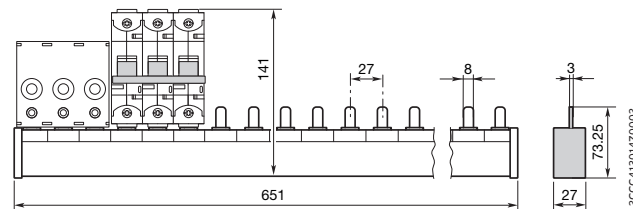

S800-BBPC120

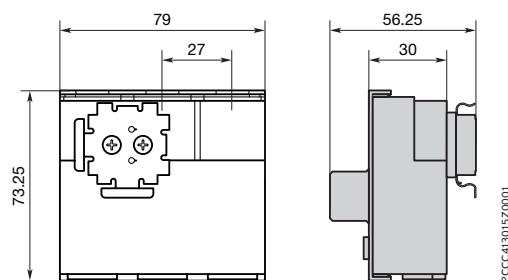

Pole dimensions

High performance MCB

S800-RD +
S800-RHE

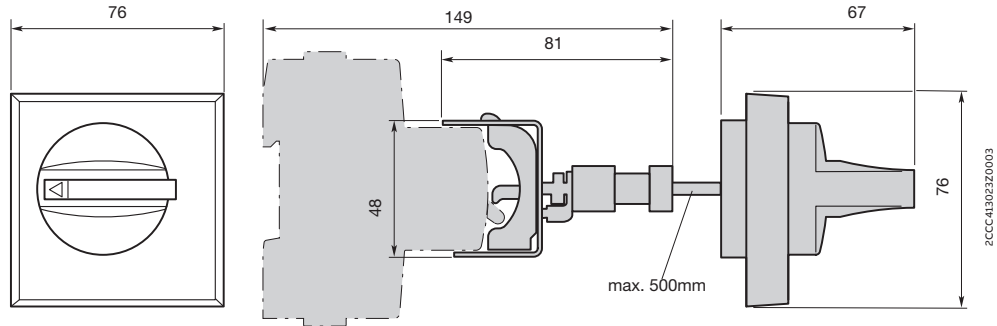

S802-LINK50
S802-LINK125

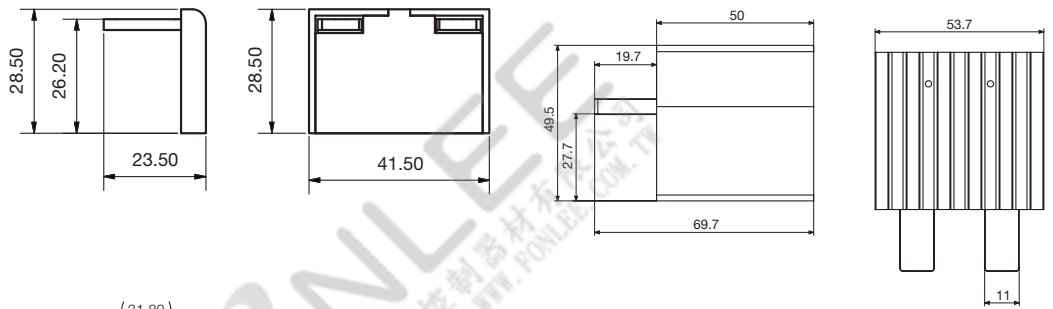

CMS-100S8

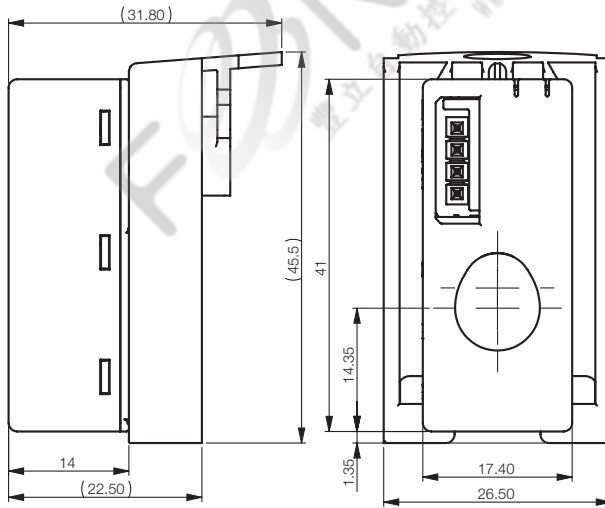

CMS-200S8

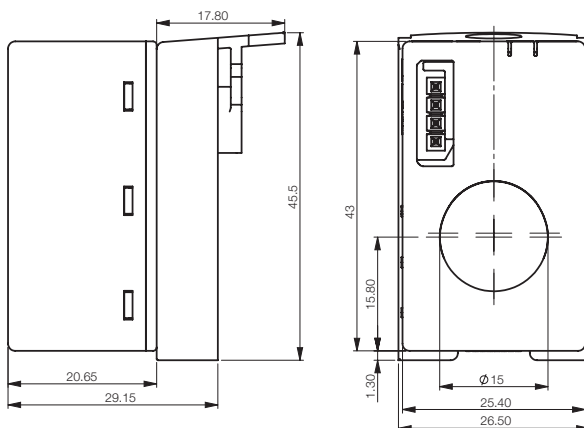

Dimensions of accessories

CMS-600

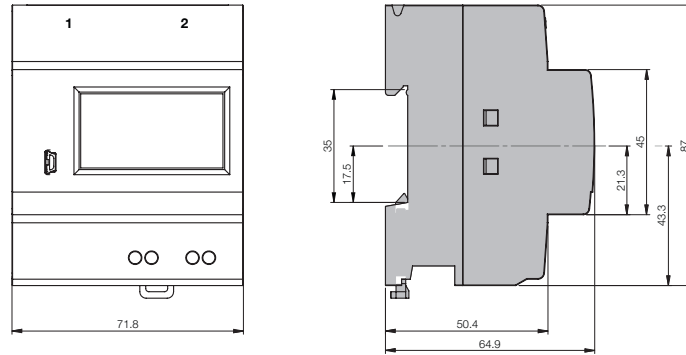

DDA802

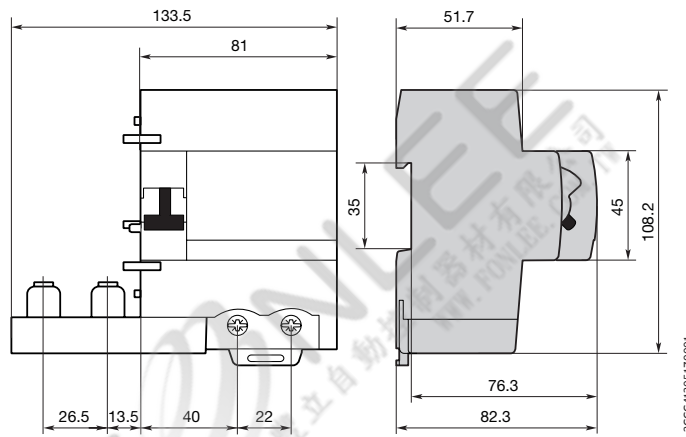

DDA803

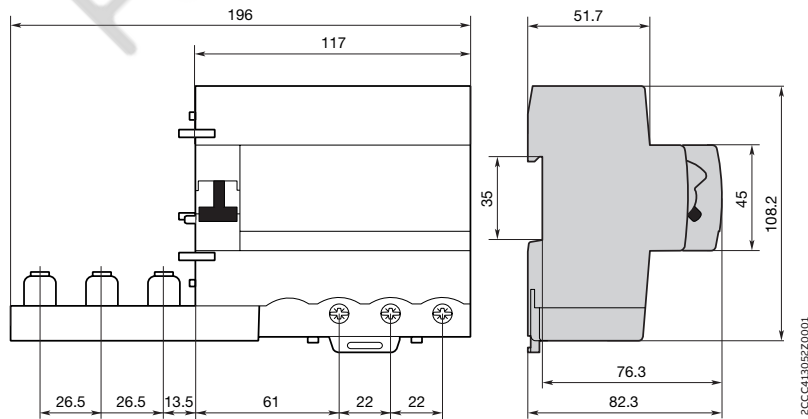

DDA804

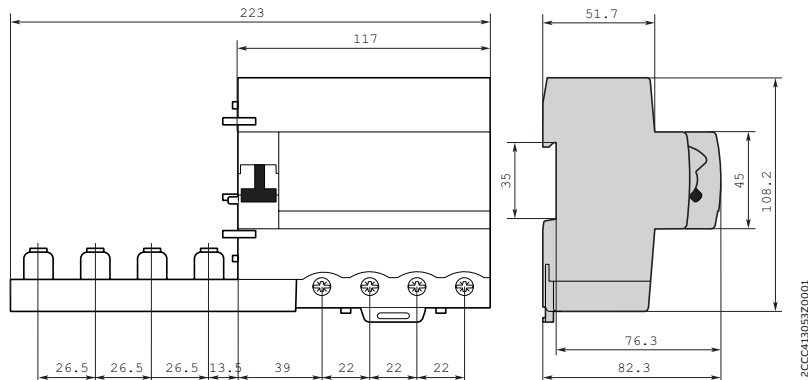

Pole dimensions

High performance MCB

DS802

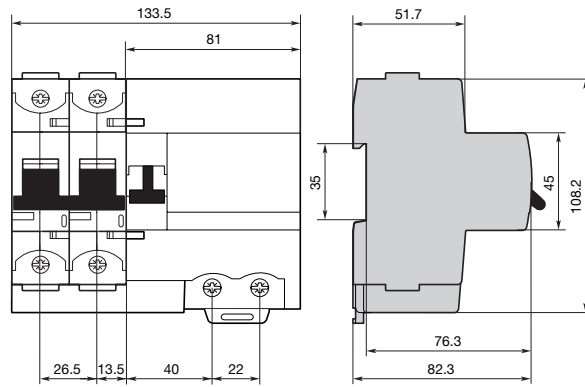

2CCC413224Z0001

DS803

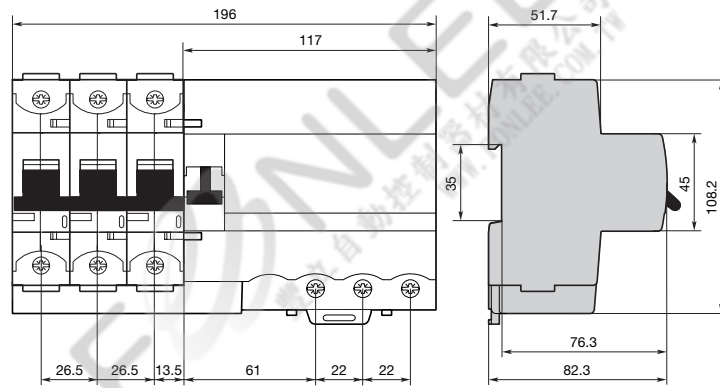

2CCC413225Z0001

DS804

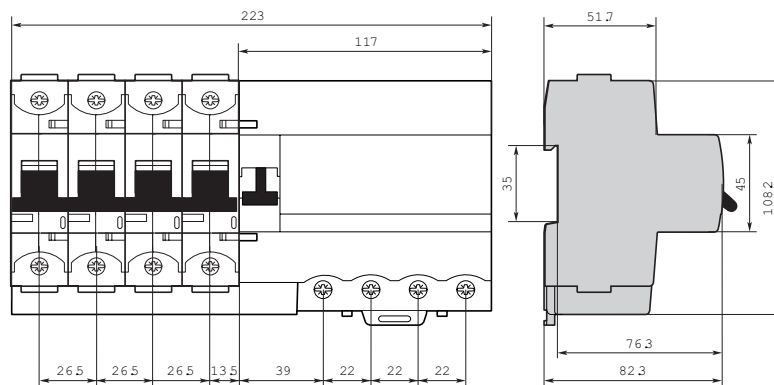









2CCC413226Z0001

FONLEE
豐立自動控制器材有限公司
www.fonlee.com.tw

Approvals and certifications S800

FONLEE
豐立自動控制器材有限公司
WWW.FONLEE.COM.TW

Approvals and certifications

	Switzer-land	Germany	China	US/Canada	Russia	Norway Marine	Germany Marine	Great Britain Marine	Italy Marine	Russia Marine
										
S800 Main devices										
S800S High performance MCB B	●	●	●	●	●	●	●	●	●	●
S800S High performance MCB C	●	●	●	●	●	●	●	●	●	●
S800S High performance MCB D	●	●	●	●	●	●	●	●	●	●
S800S High performance MCB K	●	●	●	●	●	●	●	●	●	●
S800U High performance MCB UL489				●						
S800S High performance MCB KM					●					
S800S High performance MCB UCB	●	●	●		●					●
S800S High performance MCB UCK	●	●	●		●					●
S800N High performance MCB B	●	●	●		●					
S800N High performance MCB C	●	●	●		●					
S800N High performance MCB D	●	●	●		●					
S800C High performance MCB B	●	●	●	●	●					
S800C High performance MCB C	●	●	●	●	●					
S800C High performance MCB D	●	●	●	●	●					
S800C High performance MCB K		●	●	●	●					
S800B High performance MCB B	●	●	●		●					
S800B High performance MCB C	●	●	●		●					
S800B High performance MCB D	●	●	●		●					
S800B High performance MCB K	●	●	●		●					
S800PV-SP High performance MCB		●								
S800HV High performance MCB C				●						
S800HV High performance MCB K				●						
S800PV-SD High performance MCB		●								
S802PV-M-H High performance MCB		●	●							
S800 accessories										
S800-AUX	●	●		●		●	●	●	●	●
S800-AUX/ALT	●	●	●	●		●	●	●	●	●
S800-NT	●		●							
S800W-RSU				●						
S803S-SCL						●	●		●	●
S803W-SCL-SR			○*	●		●	●			
S800-SCL-SR			○*			●				
S800-SOR				●						
S800-UVR				●						

● devices are approved
 ○* exempted (not required to have CCC approval)

FONLEE
豐立自動控制器材有限公司
WWW.FONLEE.COM.TW

FONLEE
豐立自動控制器材有限公司
WWW.FONLEE.COM.TW

