



SHIHLIN ELECTRIC
士林電機

www.seec.com.tw



2019.05 版

模鑄式變壓器

Cast Resin Transformer



工廠驗證



INTEGRATION OF POWER SYSTEM

Contents

一、產品規範	1
Product Specification	
二、高效率模鑄式變壓器	2
High Efficiency Cast Resin Transformer	
(1) 特點 Features	2
(2) 基本規格與特性 Specifications & Performances	3
三、高壓模鑄式變壓器	5
High Voltage Cast Resin Transformer	
四、低壓模鑄式變壓器	7
Low Voltage Cast Resin Transformer	
五、低壓乾式變壓器	9
Low Voltage Dry type Transformer	
六、使用上應注意事項	11
Using Attention	



一、產品規範

Product Specification

型式 | Type

士林模鑄變壓器是以樹脂真空灌鑄成型之變壓器，適用於屋內場所。

Shihlin molded transformers are made by resin vacuum casting for indoor application.

規格 | Specification

- 依據標準IEC 60076-11或各國國家標準
- 電壓等級：36kV/24kV/12kV及以下
- 相數：單相或三相
- 容量：依各國國家標準建議容量
- 分接頭範圍：±2.5%，±5%
- 接線方式：Dyn1或Dyn11
(其它接線也可按需要製作)
- Base on IEC 60076-11 or the National Standards of each country
- Voltage level: 36kV/24kV/12kV or below
- Number of Phases: Single phase or 3-phase
- Power Capacity: According to suggestion of each country's National standards.
- Tapping range: ±2.5%, ±5%
- Connection Symbol: Dyn1 or Dyn11 (Other connection are available to meet requirements)

溫度 | Temperature

- 依據IEC 60076-11
- 高壓繞組：F級
- 低壓繞組：F級
- 最大周溫：40°C
- 溫升限值：100K
- 最高容許溫度：155°C
- Based on IEC 60076-11
- High Voltage Winding: F Class
- Low Voltage Winding: F Class
- Maximum Ambient Temperature: 40°C
- Temperature-Rise Limitation: 100 K
- Max permissible temperature: 155°C

公差值 | Tolerance

- 依據IEC 60076-11
- 總損失：+10%
- 無載損：+15%
- 有載損：+15%
- 阻抗電壓：±10%
- 噪音值(dB)：+3dB
- Based on IEC 60076-11
- Total Loss: +10%
- No-Loading Loss: +15%
- Loading Loss: +15%
- Impedance: ±10%
- Noise level(dB): +3dB

產品範圍 | Product Range

- 最大容量：15000 kVA
- 最大電壓：36kV
- Max. Capacity: 15000 kVA
- Max. Voltage: 36kV

產品品質認證 | Product Quality Certification

- ISO9001、ISO14001、OHSAS18001
- KEMA、SCB11、環保標章
- 原製造廠家及TAF認證
- IEC最高等級C2(耐候試驗)、E2(環境試驗)、F1(耐燃試驗)
- 台灣大電力5000kVA短路試驗及4000/5000kVA定型試驗
- ISO9001、ISO14001、OHSAS18001
- KEMA、SCB11、Green Mark
- Original manufacturer and TAF certification
- IEC C2(climatic class 2)、E2(environmental class 2)、F1(Fire behavior class 1)
- TERTEC 5000kVA short-circuit test and 4000/5000kVA type test

二、高效率模鑄式變壓器 High Efficiency Cast Resin Transformer

(1) 特點 Features

損失與效率比較 | Power loss and Efficiency

損失-以3Ø 1500kVA為例

Power loss-In the case of 3Ø 1500kVA

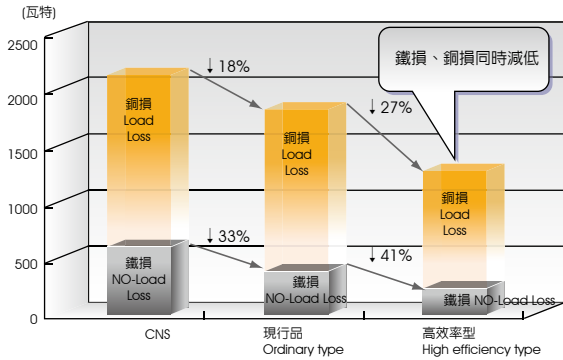

效率 (Pf=1.0) 以3Ø 1500kVA為例

Efficiency (pf = 1.0)-In the case of 3Ø 1500kVA

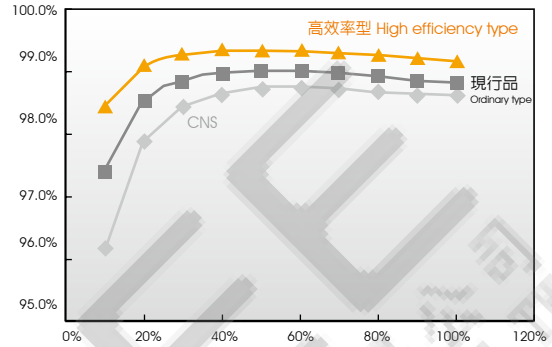

省電效果 | The fact of power saving

以三相1500kVA負載率50%，電價3.2 (元/kWh) 為例

The transformer 3Ø 1500kVA 50% loading base on NT\$3.2/kWh

• 新購品 New Product

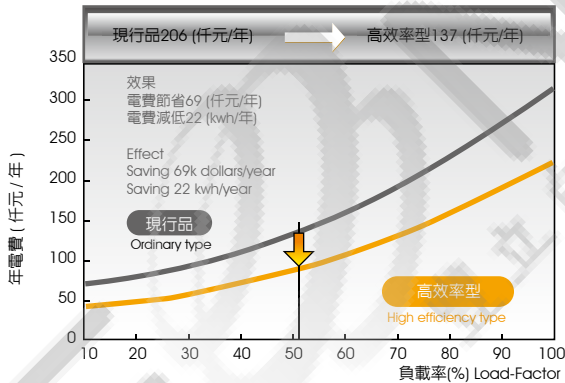

負載率越高，省電費效果越大！

• 汰舊換新 Exchange with new one

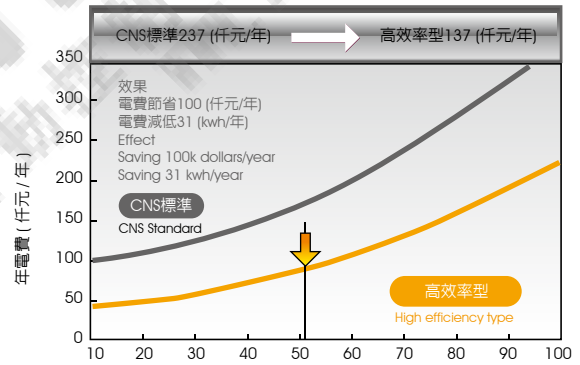

More Loading, More Saving!

靜音與環保效果 | Effect of low noise and low CO₂ Emission

- 噪音(dBa)-以3Ø 1500kVA為例
- Noise (dBa)-In the case of 3Ø 1500kVA

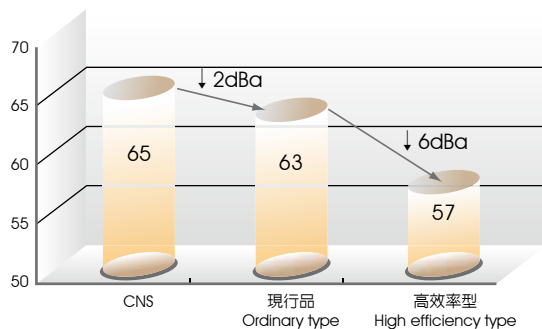

- CO₂消減量(0.423kg/kWh)-以3Ø 1500kVA負載率50%為例
- Emission (0.423kg / kWh) of CO₂-in case of 3Ø 1500kVA 50% loading

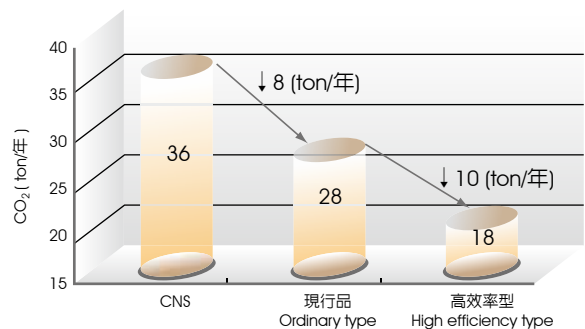

(2) 基本規格與特性 Specifications & The Characteristics

用途 | Purpose

- 具備難燃性特點，適用安全性要求高之場所：辦公大樓、醫院、車站、學校、旅館、地下街等
- 具備品質穩定特點，適用高信賴要求場所：公共事業(水利、瓦斯、電信、交通機關等)電源設備
- 具備美觀、安靜穩定特點，適用清潔、美觀要求場所：食品、電子工場設備
- It is difficult inflammation and suitable for indoor application: office building, hospitals, stations, schools, hotels, underground stores.
- It is stable reliable, and suitable for power equipment of public utilities, such as water resources, gas, telecom and transport organization.
- It is Good-looking, low noise and suitable for food processing plant and semiconductor industries.

適用條件 | Suitable condition

絕緣種類 Insulation Class	溫升限制 Temp-Rise limitation	標準絕緣強度 Standard insulation level			標準安裝方式 Installation
		公稱電壓 Standard voltage	交流試驗電壓 Ac test voltage	衝擊試驗電壓 BIL	
F級絕緣	100K	24KV級	50 kV	125 kV	底座固定型 Foundation fixed model
		600V級	3 kV	—	

電壓規格與適用標準 | Specification & Standard

相數 Phase	標準容量 Standard Capacity (kVA)	標準額定電壓 Rating Voltage (V)		結線 Connecting	標準 Standard
		一次側電壓 Primary voltage (PV)	二次側電壓 Secondary Voltage (S.V)		
3	750,1000,1250 1500,2000,2500	F24000-F23400-R22800-F22200-F21600 F12000-F11700-R11400-F11100-F10800	380Y/220 220 Δ	Dyn1 Dd0	CNS13390 IEC 60076-11

三相750~2500kVA 22800-11400V/380Y-220V特性表

The Characteristics of Three Phase 750~2500kVA 22800-11400V/380Y-220V

型式	型號	容量 Capacity (kVA)	阻抗電壓 impedance Voltage (%)	噪音 Noise (dBa)	無載電流 No-Load Current (%)	備註 Remarks
EVD3	750-2	750	6.0	55.0	1.5	• 特性裕度CNS13390、IEC 60076-11 • 特性基準溫度75°C • Tolerance refer to CNS13390 and IEC 60076-11 • Base Temperature 75°C
EVD3	1000-2	1000	6.0	56.0	1.5	
EVD3	1250-2	1250	6.0	56.0	1.5	
EVD3	1500-2	1500	6.0	57.0	1.0	
EVD3	2000-2	2000	6.0	57.0	1.0	
EVD3	2500-2	2500	6.0	57.0	1.0	

標準部品及擴大選用附件 | Standard and optional accessories

kVA	名牌 Name plate	廠牌 Brand	接地端子 Earth terminal	高壓端子 HV terminal	低壓端子 LV terminal	吊耳 Lifting lug	底座 Foundation	橫軸風扇 Cooling fan	溫控器 Temp. controller	高壓分接頭 絕緣蓋 HV switch insulation cap	車輪 Wheels
750	●	●	●	●	●	●	●	○	○	○	△
1000	●	●	●	●	●	●	●	○	○	○	△
1250	●	●	●	●	●	●	●	○	○	○	△
1500	●	●	●	●	●	●	●	○	○	○	△
2000	●	●	●	●	●	●	●	○	○	○	△
2500	●	●	●	●	●	●	●	○	○	○	△

● 標準部品Standard parts ○ 建議選用附件Suggestion parts △ 擴大選用附件Option parts

三相750~2500kVA 22800-11400V Δ / 380Y-220V 外形尺寸
 Three Phase 750~2500 kVA 22800-11400V Δ / 380Y-220V Outline Dimension

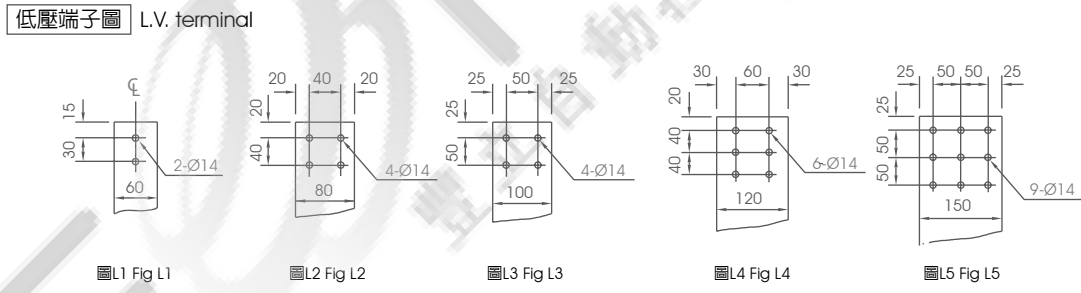
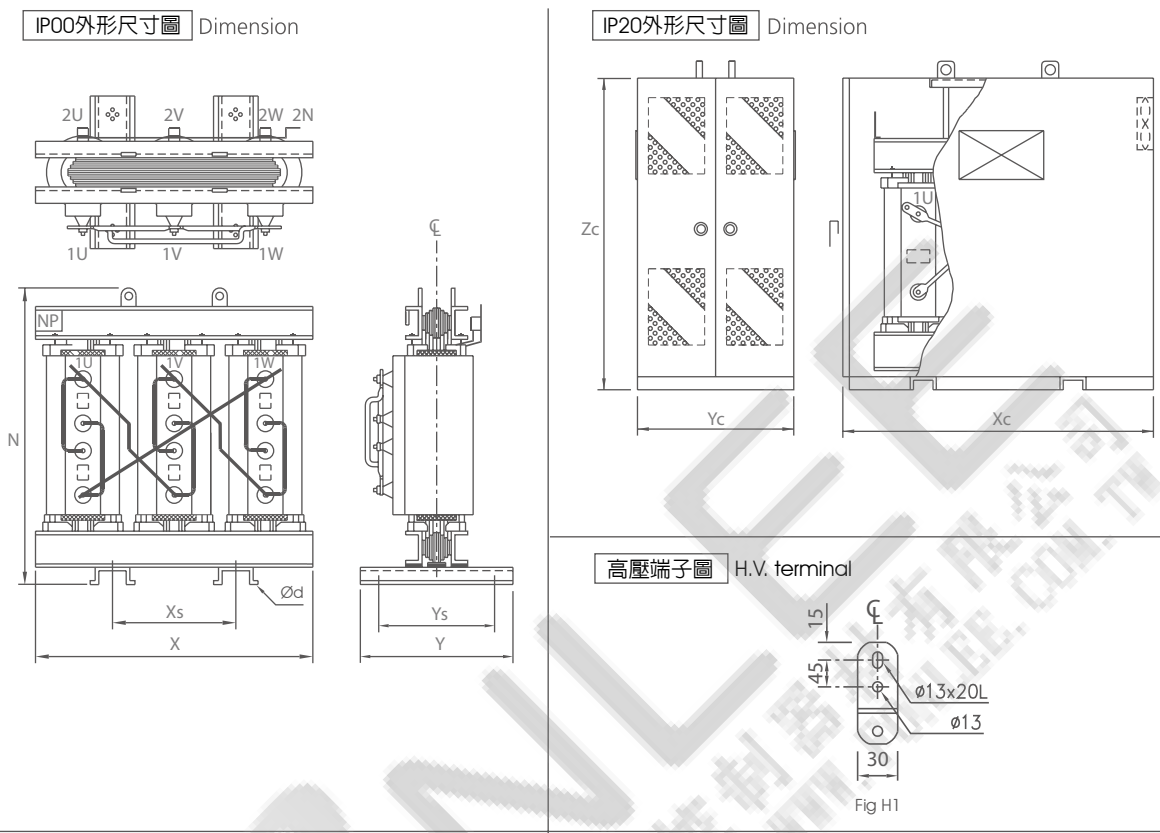

相數 Phase	容量 Capacity (kVA)	標準型 Standard Model(IP00)						外箱型 Enclosure Model(IP20)					端子圖 Terminal Drawing (380Y/220V)	
		外形尺寸 Outline Dimension (mm)			底座尺寸 Foundation Dimension (mm)			重量 Weight (kg)	外形尺寸 Outline Dimension (mm)			重量 Weight (kg)	P.V	S.V
		X	Y	Z	XS	YS	d		XC	YC	ZC			
3	750	1500	1060	1780	900	900	19	2200	2000	1500	2200	2800	圖L1 Fig.L1	
	1000	1600	1060	1900	900	900	19	2700	2200	1600	2350	3350	圖H1 Fig.H1 圖L2 Fig.L2	
	1250	1700	1160	1820	1000	1000	19	3200	2200	1600	2350	3850	圖L3 Fig.L3	
	1500	1750	1160	1880	1000	1000	19	3600	2400	1600	2350	4300	圖L4 Fig.L4	
	2000	1850	1160	2060	1000	1000	19	4650	2400	1700	2600	5400	圖H1 Fig.H1 圖L5 Fig.L5	
	2500	1950	1260	2180	1100	1100	19	5600	2600	1700	2700	6350	圖L5 Fig.L5	

三、高壓模鑄式變壓器

High Voltage Cast Resin Transformer

技術資料與外形尺寸 Technical Data and Dimensions

		3Ø 60Hz			HV: 22.8-11.4kV / LV: 380(220)V			BIL: 125kV AC: 50kV (Temp. Rise 100K)												
型式	型號	容量 Capacity (kVA)	阻抗 電壓 Impedance Voltage (%)	噪音 Sound (dB)	尺寸 Dimension (mm)													重量 Weight (kg)	接線 端子 Terminal	
					H	L	W	E	F	R	T	A	B	C	X	Y	Z		LV	HV
SD	100-2	100	4	56	1310	1300	860	700	700	430	155	445	285	215	1210	805	75	1050	a	h
SD	150-2	150	4	58	1310	1300	860	700	700	435	165	450	290	220	1210	805	75	1100	a	h
SD	200-2	200	4	60	1330	1300	860	700	700	435	192	450	290	220	1220	815	75	1200	a	h
SD	250-2	250	4	60	1470	1350	860	700	700	450	170	460	300	205	1450	965	75	1350	a	h
SD	300-2	300	6	62	1475	1300	860	700	700	440	165	455	295	205	1445	965	75	1300	a	h
SD	400-2	400	6	62	1470	1350	860	700	700	455	177	460	300	225	1380	965	75	1450	b	h
SD	500-2	500	6	62	1515	1450	960	800	800	472	187	490	330	230	1425	965	97	1650	b	h
SD	600-2	600	6	64	1615	1450	960	800	800	485	205	475	315	245	1525	1110	97	1950	b	h
SD	750-2	750	6	64	1740	1500	1060	900	900	493	197	500	340	245	1645	1270	93	2050	b	h
SD	1000-2	1000	6	64	1900	1550	1060	900	900	510	200	510	350	250	1795	1380	93	2400	c	h
SD	1250-2	1250	6	65	2040	1600	1060	900	900	528	200	520	360	260	1990	1540	89	2950	d	h
SD	1500-2	1500	6	65	2040	1700	1060	900	900	553	210	530	370	270	2020	1540	89	3250	e	h
SD	2000-2	2000	6	66	2145	1800	1160	1000	1000	585	223	550	390	280	2175	1625	132	4050	f	h
SD	2500-2	2500	6	68	2325	1850	1260	1100	1100	616	229	565	405	295	2315	1735	117	4900	f	h
SD	3000-2	3000	6	68	2345	2050	1260	1100	1100	675	260	590	430	340	2400	1755	102	6050	g	h

乾式變壓器經過一段長時間（一個月以上）的存放，在送電運轉前須將心體乾燥處理。
When dry-type transformer is stored during a long time (at least over one month), the main body should be dried before operating.

外形尺寸 | Diagram of Dimensions

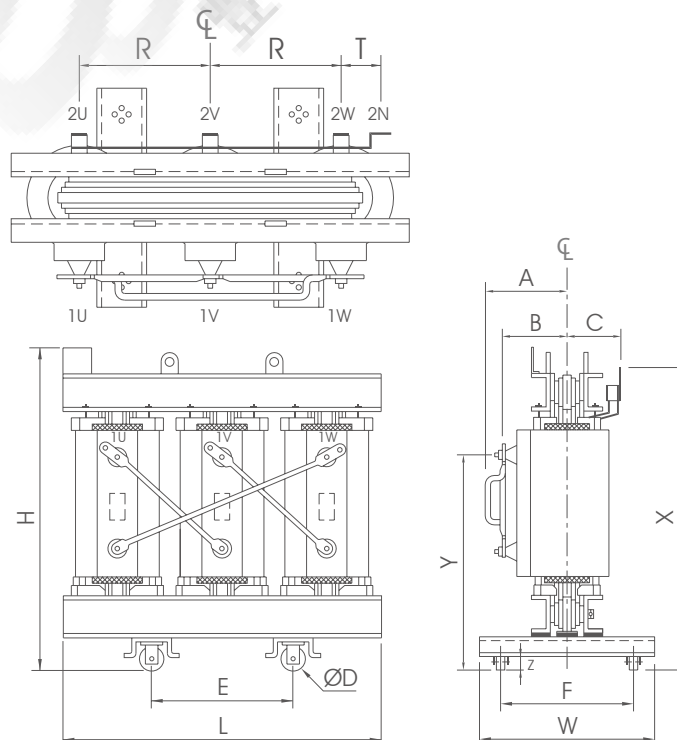

高低壓端子圖 | High/Low Voltage Terminal Diagram

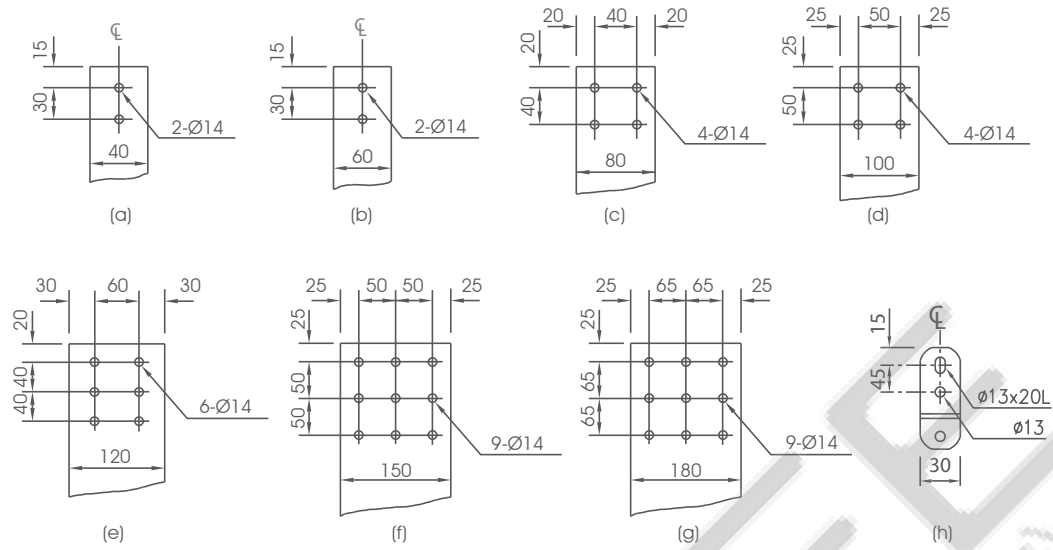

產品外觀圖 | Product Photograph



標準配件 | Standard Accessory

高低壓接線端子 / 無電壓分接頭

High and low voltage terminals/ No load tapping changer

銘牌 / 接地端子 / 吊耳 / 車輪

Name plate/ Earth terminal/ Lifting lug/ Wheel

選購配件 | Optional Accessory

外箱保護 / 冷卻風扇 / 針盤溫度計 / 溫度電驛

Enclosure/ Cooling Fan/ Dial type thermal meter/ Thermal relay

四、低壓模鑄式變壓器 Low Voltage Cast Resin Transformer

3Ø 60Hz 無外箱 IP00 (Three Phase 60Hz Without Enclosure)

容量 Capacity (kVA)	額定Rated			外形尺寸Dimension(mm)					重量 Weight (kg)
	高壓側 High Voltage (V)	低壓側 Low Voltage (V)	阻抗電壓 Impedance Voltage (%)	H	L	W	E	F	
3				340	325	260	200	190	45
5				410	325	260	200	190	55
7.5			≤4.5	395	445	260	250	190	70
10				430	445	260	250	190	80
15		220	3.0~5.5	455	445	300	250	230	100
20		110		515	445	300	250	230	120
25	480	380Y/220	3.0~5.5	535	535	300	300	230	140
30	460	220Y/127		585	535	300	300	230	155
37.5	440	208Y/120	4.0~6.0	620	740	380	500	300	195
50	380	200Y/115		680	740	380	500	300	220
75	220	199Y/115	4.0~6.0	810	800	390	550	300	320
100		190Y/110		890	860	450	550	350	410
150			4.5~7.0	1085	860	450	550	350	490
200				1030	1110	550	750	450	690
250			1090	1110	550	750	450	785	

外形尺寸 | Diagram of Dimensions

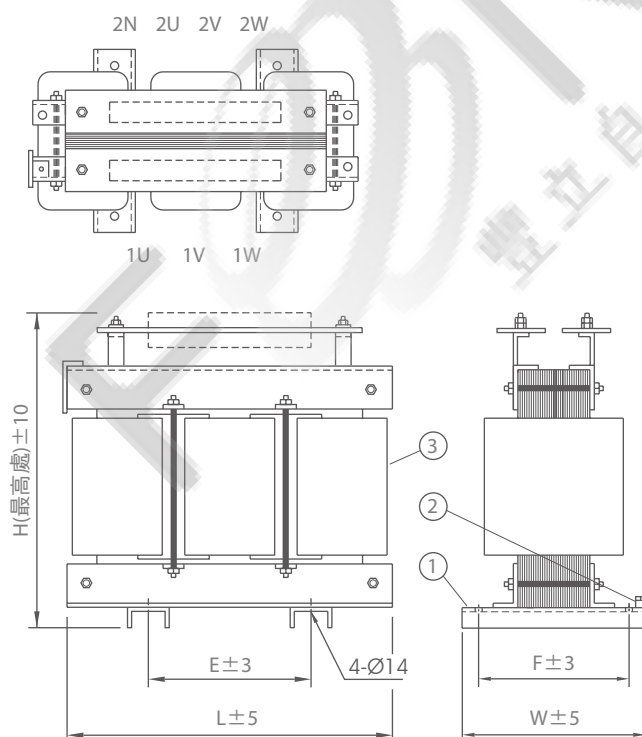

表一

容量 Capacity	噪音基準 Sound Level
0-50 kVA	50 dBa
51-150 kVA	55 dBa
151-250 kVA	58 dBa

產品規格 | Product Specification

- 依據標準：IEC 60076-11、CNS13390
 - 絕緣耐熱等級：F (155°C)
 - 線圈溫升：100K
 - AC.耐壓：3kV
 - 噪音值：如(表一)
- Standard：IEC 60076-11、CNS13390
 - Insulation thermal Class: F (155°C)
 - Coil Temperature Rise: 100K
 - AC. Withstand Voltage: 3kV
 - Noise Level: According to table 1.

※依容量、結線不同變壓器端子出線及結構將有所改變，因此以上外形僅供參考。(外形尺寸不變)

According to the difference of capacity and connection, terminal and structure would be changed. Therefore, the outline of transformer is for reference only (Nevertheless, the dimension won't be changed).

3Ø 60Hz 附外箱 IP20 (Three Phase 60Hz With Enclosure)

容量 Capacity (kVA)	額定Rated			外形尺寸Dimension(mm)					重量 Weight (kg)
	高壓側 High Voltage (V)	低壓側 Low Voltage (V)	阻抗電壓 Impedance Voltage (%)	H	L	W	E	F	
3	480	220	≤4.5	535	385	250	335	150	60
5				535	385	250	335	150	70
7.5				585	505	300	455	200	92
10				585	505	300	455	200	100
15				585	505	300	455	200	120
20				645	505	300	455	200	140
25				715	595	350	545	250	170
30				735	595	350	545	250	185
37.5				890	810	400	500	300	245
50				890	810	400	500	300	270
75	1100	880	450	550	350	385			
100	1135	940	450	550	350	470			
150	1320	940	450	550	350	565			
200	1355	1180	600	750	500	795			
250	1415	1210	600	750	500	895			

外形尺寸 | Diagram of Dimensions

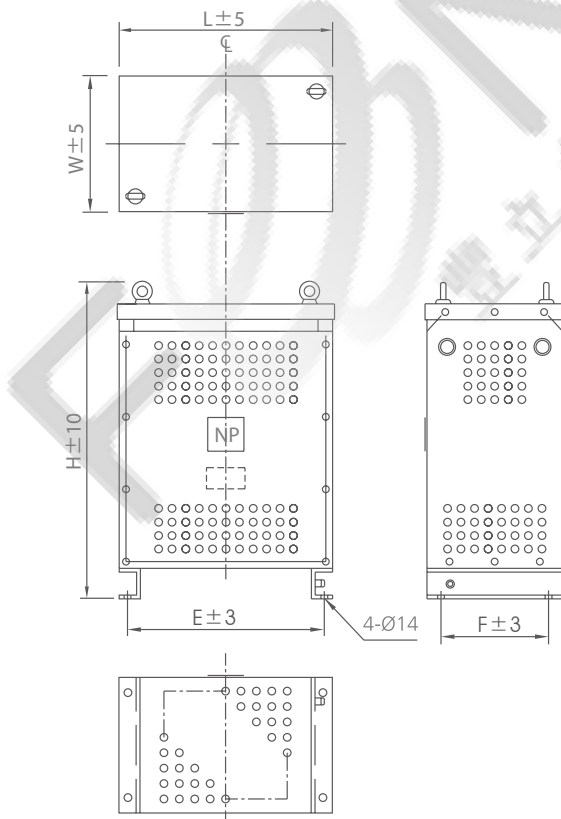

表一

容量 Capacity	噪音基準 Sound Level
0-50 kVA	50 dBa
51-150 kVA	55 dBa
151-250 kVA	58 dBa

產品規格 | Product Specification

1. 依據標準：IEC 60076-11、CNS13390
 2. 絕緣耐熱等級：F (155°C)
 3. 線圈溫升：100K
 4. AC.耐壓：3kV
 5. 噪音值：如(表一)
1. Standard: IEC 60076-11、CNS13390
 2. Insulation thermal Class: F (155°C)
 3. Coil Temperature Rise: 100K
 4. AC. Withstand Voltage: 3kV
 5. Noise Level: According to table 1.

※依容量、結線不同變壓器端子出線及結構將有所改變，因此以上外形僅供參考。(外形尺寸不變)

According to the difference of capacity and connection, terminal and structure would be changed. Therefore, the outline of transformer is for reference only (Nevertheless, the dimension won't be changed).

五、低壓乾式變壓器

Low Voltage Dry Type Transformer

3Ø 60Hz 無外箱 IP00 (Three Phase 60Hz Without Enclosure)

容量 Capacity (kVA)	額定Rated			外形尺寸Dimension(mm)					重量 Weight (kg)
	高壓側 High Voltage (V)	低壓側 Low Voltage (V)	阻抗電壓 Impedance Voltage (%)	H	L	W	E	F	
3				320	320	260	200	190	35
5				375	320	260	200	190	40
7.5				400	320	260	200	190	50
10			≤4.5	385	375	300	250	230	70
15		220		430	375	300	250	230	80
20		110		510	375	300	250	230	95
25	480	380Y/220		530	415	300	250	230	120
30	460	220Y/127		525	530	340	300	270	135
37.5	440	208Y/120		555	530	340	300	270	150
50	380	200Y/115		575	590	400	400	300	200
75	220	199Y/115		700	640	400	450	300	250
100		190Y/110	3.0~5.5	880	800	450	550	350	370
150				1050	800	450	550	350	450
200				1030	980	550	650	450	600
250				1090	980	550	650	450	690

外形尺寸 | Diagram of Dimensions

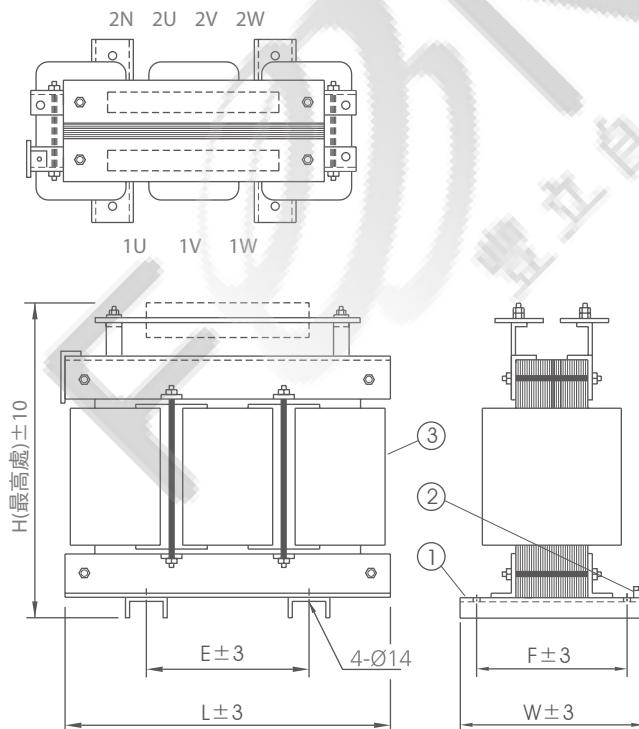

表一

容量 Capacity	噪音基準 Sound Level
0-50 kVA	50 dBa
51-150 kVA	55 dBa
151-250 kVA	58 dBa

產品規格 | Product Specification

1. 依據標準：IEC 60076-11、CNS13390
 2. 絕緣耐熱等級：H (180°C)
 3. 線圈溫升：125K
 4. AC.耐壓：3kV
 5. 噪音值：如(表一)
1. Standard: IEC 60076-11、CNS13390
 2. Insulation thermal Class: H (180°C)
 3. Coil Temperature Rise: 125K
 4. AC. Withstand Voltage: 3kV
 5. Noise Level: According to table 1.

※依容量、結線不同變壓器端子出線及結構將有所改變，因此以上外形僅供參考。(外形尺寸不變)

According to the difference of capacity and connection, terminal and structure would be changed. Therefore, the outline of transformer is for reference only (Nevertheless, the dimension won't be changed).

3Ø 60Hz 附外箱IP20 (Three Phase 60Hz With Enclosure)

容量 Capacity (kVA)	額定Rated			外形尺寸Dimension(mm)					重量 Weight (kg)
	高壓側 High Voltage (V)	低壓側 Low Voltage (V)	阻抗電壓 Impedance Voltage (%)	H	L	W	E	F	
3	480	220	≤4.5	495	370	250	320	150	47
5				495	370	250	320	150	50
7.5				520	370	250	320	150	60
10				510	435	300	385	200	85
15				560	435	300	385	200	100
20				635	435	300	385	200	110
25				690	475	350	425	250	135
30				715	595	350	545	250	165
37.5				715	595	350	545	250	180
50				780	660	400	400	300	230
75	3.0~5.5	190Y/110	895	710	450	450	350	300	
100			1100	880	450	550	350	430	
150			1280	880	450	550	350	510	
200			1355	1050	600	650	500	690	
250			1415	1080	600	650	500	780	

外形尺寸 | Diagram of Dimensions

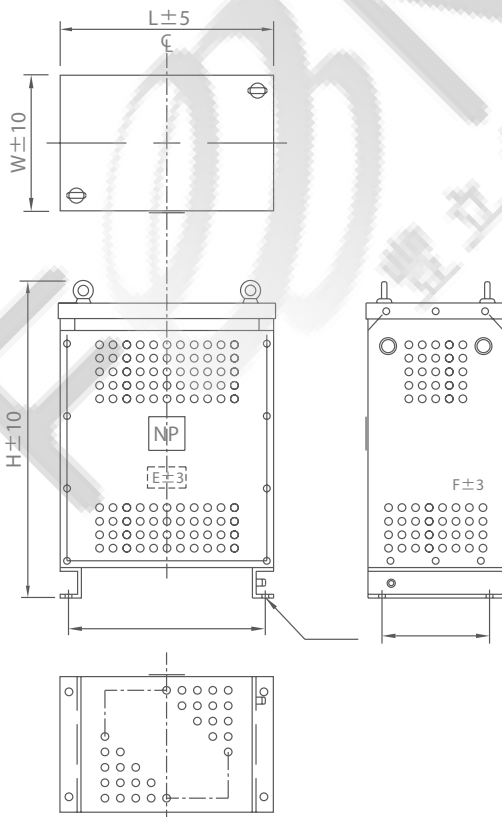

表一

容量 Capacity	噪音基準 Sound Level
0-50 kVA	50 dBa
51-150 kVA	55 dBa
151-250 kVA	58 dBa

產品規格 | Product Specification

1. 依據標準：IEC 60076-11、CNS13390
 2. 絕緣耐熱等級：H (180°C)
 3. 線圈溫升：125K
 4. AC.耐壓：3kV
 5. 噪音值：如(表一)
1. Standard: IEC 60076-11、CNS13390
 2. Insulation thermal Class: H (180°C)
 3. Coil Temperature Rise: 125K
 4. AC. Withstand Voltage: 3kV
 5. Noise Level: According to table 1.

※依容量、結線不同變壓器端子出線及結構將有所改變，因此以上外形僅供參考。(外形尺寸不變)

According to the difference of capacity and connection, terminal and structure would be changed. Therefore, the outline of transformer is for reference only (Nevertheless, the dimension won't be changed).

六、使用上應注意事項 Using Attention

(1) 安全距離 Safety Distance

- 電纜配線與變壓之最小安全距離，如圖1所示
- 變壓器放置在完封箱(盤)內時，其對箱壁最小絕緣距離，如圖2與表1所示
- The minimum safety distance between cable wire and transformer is shown as in Diagram 1.
- The minimum insulation distance from the transformer to the fully sealed case(plate) wall is shown as in Diagram 2 and Table 1.

圖1 Diagram 1



圖2 Diagram 2



系統電壓 System Voltage (kV)	衝擊電壓 BIL (kV)	對地距離 Distance X (mm)
7.2	60	90
12	75	130
17.5	95	210
24	125	210
36	170	320

(2) 通風 Well ventilated

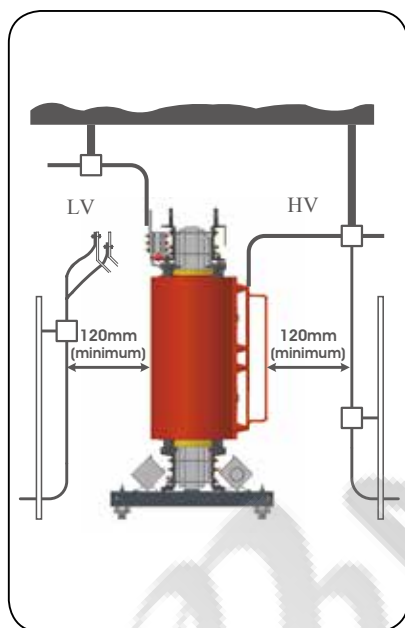
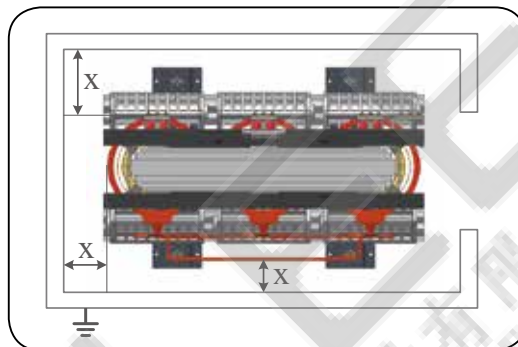
- 變壓器一般均安裝於屋內或盤內，維持變壓器周圍溫度不使太高，良好的通風與換氣設施勢必要的，通常損失1kW則需相當於4m³/分以上的空氣量，這也是安裝場所至少所必需的通風口面積，室內進風口與出風口面積應符合下列關係

$$S = 0.18P / \sqrt{H}$$

$$S' = 1.1 \times S$$

S : 進氣面積(m²)

S' : 出氣面積(m²)

P : 變壓器總損失(kW)

H : 進氣與出氣口之高度差

- Usually transformers are installed indoors or in a plate. In order to avoid the temperature around transformer getting too high, it is necessary to have good ventilation facilities installed. Normally a loss of 1kW is equivalent to an air volume of more than 4m³/min, i.e. the minimum area required for ventilation openings at the installation site. The areas of indoor ventilation intake and outlet should meet the following relationship requirements:

$$S = 0.18P / \sqrt{H}$$

$$S' = 1.1 \times S$$

S : Intake Area(m²) S' = Outlet Area(m²)

p : Transformer Total Losses(kW)

H : Height Difference between the Installation Location of Intake and Outlet

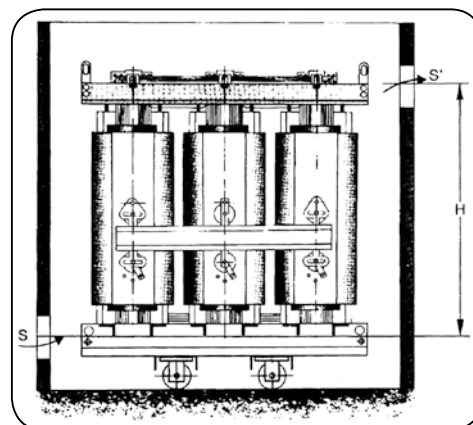

(3) 安裝場所 Installation

- 標高：變壓器設計於海拔1000公尺（3300英尺）以下使用
- 周圍溫度：適用如下表 當周溫超過40°C時，對變壓器輸出容量將限制如下表

區分	空氣溫度	最大周溫	允許負載
最高溫度	40°C	40°C	P (全容量)
日平均溫度	30°C	45°C	0.97×P
年平均溫度	20°C	50°C	0.94×P
		55°C	0.90×P

- Elevation: The transformer is designed to be used under 1000m (3300ft) above the sea level.
- Ambient Temperature: Applied as in the table shown below.

Distinction	Air Temperature
Maximum Temperature	40°C
Daily Average Temperature	30°C
Yearly Average Temperature	20°C

When the ambient temperature exceeds 40°C, restrictions as shown in the table below will be made on the transformer output capacity:

Maximum Ambient Temperature	Permissible load
40°C	P (full capacity)
45°C	0.97×P
50°C	0.94×P
55°C	0.90×P

(4) 詢價與訂貨

- 承蒙詢價或訂貨時請提供下列資料

相數 number of phase				
頻率 frequency				Hz
額定容量 rated				kVA
額定電壓 rated voltage	高壓 HV	kV	低壓 LV	V
接線符號 connection symbol	高壓 HV		低壓 LV	
分接範圍 tapping range				
阻抗電壓 impedance voltage				%
冷卻方式 cooling method				(AN or AF)
保護等級 protection level				(IP00, IP20, 其他other)
是否配置溫控系統 optional accessories				
訂貨數量 quantities ordered				
交貨日期 time of delivery				
其他 miscellaneous				



SK變壓器為一般變壓器的

3倍強度



- 保證氫氣 < 400 ppm，部分放電 < 200 pC
- surge V / source V \approx 3 p.u.(耐壓強度)
- 適用負載：變壓變頻(VVVF)，非線性負載及多相整流負載(例如：三相六脈波)
- 保固兩年

SK type 變壓器



高效率模鑄式變壓器
Cast Resin Transformer



比流器 / 比壓器
Current Transformer
Voltage Transformer



高低壓電容器/電抗器
HV/LV Capacitors / Reactor



配電盤
Switchgear & Controlgear



避雷器 / 分段開關
Lightning Arrester /
Disconnecting Switches



智慧型電表 / SCADA
Smart Meter / SCADA



智慧型電容器調諧組/盤
Smart Capacitors / Panel



主動式濾波器 / 自動虛功補償器
Active Power Filter /
Static Var Generator

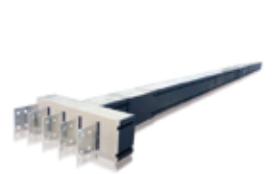

高/低壓匯流排
HV/LV Busway

產品諮詢專線0800-524040 (我愛士林士林) 服務時間08:30~17:30

台北 TEL. 02-2541-9822 | 新竹 TEL. 03-598-1210 | 台中 TEL. 04-2461-0466 | 台南 TEL. 06-237-1246 | 高雄 TEL. 07-316-0228

INTEGRATION OF POWER SYSTEM

重電事業群

電力變壓器、模鑄式變壓器、油浸式配電變壓器、配電盤、分段開關/避雷器、高低壓進相電容器、智慧型低壓電容器盤、
比流器/比壓器、智能型數位集合式電表、智能型三相多功能電子式電度表、智能型預付費單相電子式電度表

www.seec.com.tw

總公司 HEAD OFFICE	111 臺北市中山北路六段88號16樓 16 F, No.88, Sec. 6, ChungShan N. Rd., Taipei City 111, Taiwan	TEL. 02-2834-2662 FAX. 02-2836-6187
重電廠 Heavy Electric System	303 新竹縣新竹工業區中華路23號 No.23, ChungHwa Rd., Huko Hsiang, HsinChu County 303, Taiwan	TEL. 03- 598-1921 FAX. 03- 598-1480
重電外銷處 Heavy Electric Export Sales Dept.	111 台北市中山北路六段88號12樓 12F, No.88, Sec.6, ChungShan N. Rd., Taipei City 111, Taiwan	TEL. +886-2-2832-1556 FAX. +886-2-2832-1003
配電盤事業 Panelboard System Div.	303 新竹縣新竹工業區中華路23號 No.23, ChungHwa Rd.,Huko Hsiang, HsinChu County 303, Taiwan	TEL. 03-598-1921 ext.236 FAX. 03-597-3774

台北分公司 Taipei Branch	104 台北市長安東路一段9號3F 3F, No.9, Sec. 1, ChangAn E. Rd., Taipei City 104, Taiwan	TEL. 02-2541-9822 FAX. 02-2581-2665
新竹分公司 Hsinchu Branch	303 新竹縣湖口鄉鳳凰村中華路23號 No. 23, ChungHwa Rd., Huko Hsiang, Hsinchu County 304, Taiwan	TEL. 03-598-1210 FAX. 03-598-5200
台中分公司 Taichung Branch	407 台中市西屯區台灣大道四段1338號 No.1338, Sec. 4, Taiwan Blvd., Taichung, Taiwan. 40764	TEL. 04-2461-0466 FAX. 04-2461-0468
台南分公司 Tainan Branch	701 台南市中華東路一段198號 No. 198, Sec. 1, ChungHwa E. Rd., Tainan City 701, Taiwan	TEL. 06-237-1246 FAX. 06-237-1279
高雄分公司 Kaohsiung Branch	807 高雄市三民區中華二路250號 No. 205, ChungHwa 2 Rd., Kaohsiung City 807, Taiwan	TEL. 07-316-0228 FAX. 07-316-0226

經銷商

2019.05